

3988  
COMMAND BRIDGE  
MOTORYACHT  
OWNER'S MANUAL SUPPLEMENT

**BAYLINER®**



**Port Engine Serial Number:** \_\_\_\_\_

**Stbd. Engine Serial Number:** \_\_\_\_\_

**Hull Identification Number:** \_\_\_\_\_

***Hull Identification Number***

The Hull Identification Number (HIN) is located on the starboard side of the transom. Be sure to record the HIN (and the engine serial numbers) in the space provided above. Please refer to the HIN for any correspondence or orders.

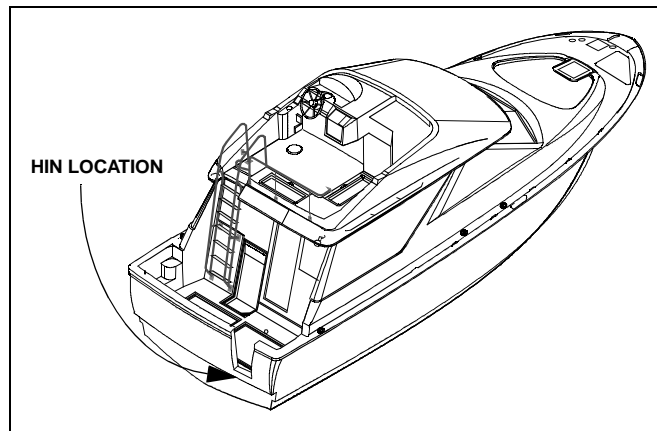

**© 2001 Bayliner Technical Publications. All rights reserved.**

No part of this publication may be reproduced, stored in any retrieval system, or transmitted in any form by any means, electronic, mechanical, photocopying, recording or otherwise, without prior written permission of Bayliner.

Printed in the United States of America.

**General Notes**

The material in this document is for information only and is subject to change without notice. While reasonable efforts have been made in the preparation of this document to assure its accuracy, Bayliner assumes no liability resulting from errors or omissions in this document, or from the use of information contained herein.

Due to our commitment to product improvement, Bayliner reserves the right to make changes in the product design, specifications, and equipment at any time without notice or obligation. Illustrations and/or photos may show optional equipment.

All Bayliner products meet or exceed USCG (United States Coast Guard) and/or NMMA (National Marine Manufacturer's Association) construction standards. Manufactured with 1,1,1 Trichloroethane, a substance which harms public health and environment during the manufacturing process by destroying ozone in the upper atmosphere.

**Proprietary Rights**

This document discloses subject matter in which Bayliner has proprietary rights. The information and design disclosed herein were originated by and are the property of Bayliner. Neither receipt nor possession thereof confers or transfers any right to reproduce, copy, alter or disclose the document or any part thereof, any information contained therein, or to construct boats or any item from it, except by written permission from or written agreement with Bayliner. This document is to be returned upon request to Bayliner.

# CONTENTS

---

## CHAPTER 1: WELCOME ABOARD!

- 1 Dimensions and Capacities
- 1 Layout View
- 1 Dealer Service
- 1 About Your Limited Warranty
- 2 Boating Experience
- 2 Safety Standards
- 2 Engine/Accessories Guidelines
- 3 Qualified Maintenance
- 3 Special Care For Moored Boats
  - 3 *Sacrificial Anodes (Zinc Plates)*
- 4 Carbon Monoxide (CO)
  - 5 *Sources of CO*
  - 5 *Carbon Monoxide Alarm System*
  - 5 *What To Do If Carbon Monoxide Is Detected*
- 6 Yacht Lifting
  - 6 *Lifting Sling Positions*

## CHAPTER 2: COMPONENTS / SYSTEMS

- 7 Hull Exterior Hardware & Drains
- 8 Deck Equipment
  - 8 *Deck Fill & Pump-out Locations*
  - 8 *Anchor Windlass*
  - 8 *Windshield Wipers*
- 9 Helm Features
  - 9 *Command Bridge Helm*
  - 10 *Lower Helm*
- 11 Navigation & Communication Equipment
  - 11 *VHF Radio*
  - 11 *Depth Finder*
  - 11 *Compass*
  - 12 *Radar/Plotter (If Equipped)*
  - 12 *Global Positioning System (GPS) (If Equipped)*
  - 12 *Autopilot (If Equipped)*
- 13 Navigation & Interior Lights
  - 13 *Spotlight*

- 14 Controls
  - 14 *Steering System*
  - 14 *Rudder Stuffing Gland*
  - 14 *Trim Tabs*
- 15 Propulsion
  - 15 *Engines*
  - 15 *Engine Room Ventilation System*
  - 15 *Engine Cooling System*
  - 16 *Exhaust System*
  - 16 *Oil Change System (If Equipped)*
- 17 Fuel System
  - 17 *Fuel Quality*
  - 17 *Fuel Filters & Separators*
  - 18 *Fuel Transfer Pump (Diesel Systems Only)*
  - 18 *Anti-siphon Valve (Gas Engines Only)*
  - 18 *Fuel Fills & Vents*
  - 19 *Fuel System Diagrams*
- 20 Shaft-Transmission Alignment
  - 20 *Shaft Log Packless Sealing System*
- 21 Electrical System
- 22 12-Volt DC System
  - 22 *Fuses and Circuit Breakers*
  - 22 *Battery Switches*
  - 23 *Batteries*
  - 23 *Engine Alternators*
  - 23 *Battery Charger*
- 24 110-Volt AC System
  - 24 *Shore Power*
  - 25 *Connecting To Shore Power*
  - 26 *Generator Power*
- 27 Fresh Water System
  - 27 *110-Volt Water Heater*
  - 28 *Transom Shower (If Equipped)*
- 28 Gray Water Drain System
  - 28 *Sump Box Cleaning*
  - 28 *Sump System Winterizing*
- 29 Seawater Systems
  - 29 *Seacocks*
  - 30 *Seawater Strainers*
  - 30 *Wash Down System (If Equipped)*
- 31 Marine Head System with Holding Tank
  - 32 *Vacuflush Head System (If Equipped)*

- 
- 33 Bilge Pumps
    - 34 *Bilge Pump Testing*
    - 34 *Autofloat Switches*
  - 35 Air Conditioner & Heater (If Equipped)
  - 36 Electric Heaters (If Equipped)
  - 36 Heat Exchanger Cabin Heater (If Equipped)
  - 37 Appliances
    - 37 *110-Volt AC/12-Volt DC Refrigerator*
    - 37 *Range/Oven*
    - 37 *Microwave Oven*
  - 37 Audio & Visual Equipment

### **CHAPTER 3: WIRING DIAGRAMS**

- 38 Standard Dual Dockside
- 39 Accessory DC Circuits
- 40 Gas Engine Electrical System
- 41 Diesel Engine Electrical System

## Hazard Boxes & Symbols

The hazard boxes and symbols shown below are used throughout this supplement to call attention to potentially dangerous situations which could lead to either personal injury or product damage. **Read ALL warnings carefully and follow all safety instructions.**

 <b>DANGER!</b>
<b>This box alerts you to immediate hazards which WILL cause severe personal injury or death if the warning is ignored.</b>

 <b>WARNING!</b>
<b>This box alerts you to hazards or unsafe practices which COULD result in severe personal injury or death if the warning is ignored.</b>

 <b>CAUTION!</b>
<b>This box alerts you to hazards or unsafe practices which COULD result in minor personal injury or cause product or property damage if the warning is ignored.</b>

<b>NOTICE</b>
<b>This box calls attention to installation, operation or maintenance information, which is important to proper operation but is not hazard related.</b>

 <b>EXPLOSION HAZARD!</b>	 <b>OPEN FLAME HAZARD!</b>	 <b>HOT HAZARD!</b>	 <b>ELECTRICAL HAZARD!</b>	 <b>CO POISONING HAZARD!</b>	 <b>PERSONAL INJURY &amp; FALLING HAZARD!</b>	 <b>ROTATING PROPELLER HAZARD!</b>
---	--	---	--	--	---	--

## CHAPTER 1: WELCOME ABOARD!

This *Owner's Manual Supplement* provides specific information about your yacht that is not covered in the *Cruiser & Yacht Owner's Manual*. Please study the *Cruiser & Yacht Owner's Manual* and this supplement carefully. Keep the *Cruiser & Yacht Owner's Manual* and this supplement on your yacht in a secure, yet readily available place.

### Dimensions and Capacities

Overall Length	Bridge Clearance	Beam	Draft	Fuel Tank Capacity (gal)	Water Tank Capacity (gal)	Holding Tank Capacity (gal)
39' 0"	14' 10"	13' 11"	3' 3"	298	100	36

### Layout View

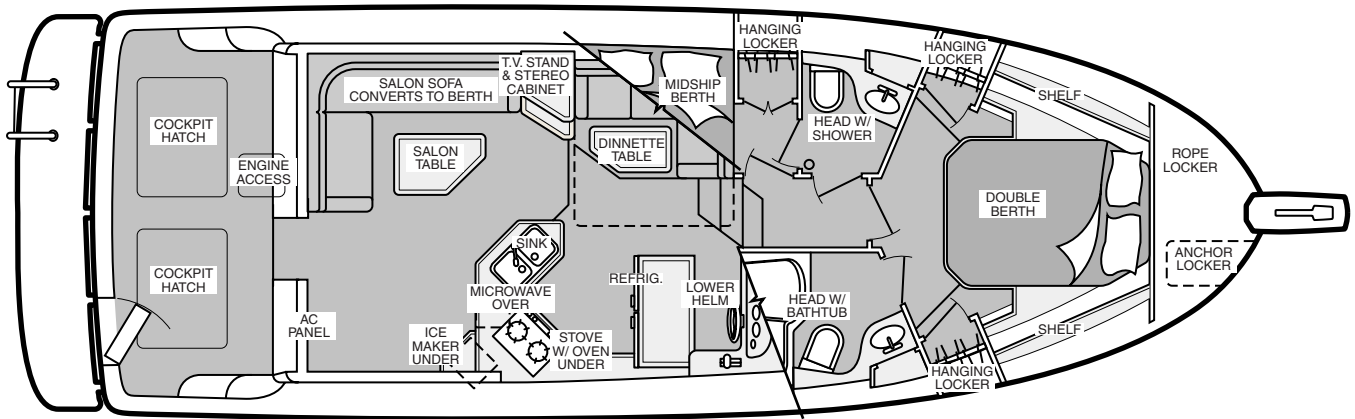

### Dealer Service

Make sure you receive a full explanation of all systems from the selling dealer before taking delivery of your yacht. Your selling dealer is your key to service. If you have any problems with your new yacht, immediately contact the selling dealer. If your selling dealer is unable to help, call us direct on our customer service hotline: 360-435-8957 or send us a FAX: 360-403-4235. A Bayliner replacement parts catalog is available online at: <http://www.baylinerparts.com>. Replacement parts can be purchased from any authorized Bayliner dealer.

### About Your Limited Warranty

Bayliner offers a Limited Warranty on each new Bayliner purchased through an authorized Bayliner dealer. A copy of the Limited Warranty was included in your owner's packet. If for any reason, you did not receive a copy of the Limited Warranty, please contact your local dealer or call 360-435-8957 for a replacement copy.

## Boating Experience

If this is your first yacht or if you are changing to a type of yacht you are not familiar with, for your own comfort and safety, please make sure that you obtain handling and operating experience before assuming command of the yacht.

Take one of the boating safety classes offered by the U.S. Power Squadrons or the U.S. Coast Guard Auxiliary. For more course information, including dates and locations of upcoming classes, contact the organizations directly:

- U.S. Power Squadrons: 1-888-FOR-USPS (1-888-367-8777) or on the Internet at: <http://www.usps.org>
- U.S. Coast Guard Auxiliary: 1-800-368-5647 or on the Internet at: <http://www.cgaux.org>

Outside the United States, your selling dealer, national sailing federation or local boat club can advise you of local sea schools or competent instructors.



### WARNING!

**CONTROL HAZARD!** A qualified operator must be in control of the yacht at all times. **DO NOT** operate your yacht while under the influence of alcohol or drugs.

## Safety Standards

Your yacht's mechanical and electrical systems were designed to meet safety standards in effect at the time it was built. Some of these standards were mandated by law, all of them were designed to insure your safety, and the safety of other people, vessels and property.

**In addition to this owner's manual supplement, read the *Cruiser & Yacht Owner's Manual* and all accessory instructions for important safety standards and hazard information.**



### DANGER!



**PERSONAL SAFETY HAZARD!** Do not allow anyone to ride on parts of the yacht not designated for such use. Sitting on seat backs, lounging on the forward deck, bow riding, gunwale riding or occupying the transom platform while underway is especially hazardous and will cause personal injury or death.



### DANGER!

**PERSONAL SAFETY HAZARD!** Always secure the anchor and other loose objects before getting underway. The anchor and other items that are not properly secured can come loose when the boat is moving and cause personal injury or death.

## Engine/Accessories Guidelines

Your yacht's engine and accessories were selected to provide optimum performance and service. Installing a different engine or other accessories may cause unwanted handling characteristics. Should you choose to install a different engine or to add accessories that will affect the yacht's running trim, have an experienced marine technician perform a safety inspection and handling test before operating your yacht again.

**Certain modifications to your yacht can result in cancellation of your warranty protection.** Always check with your dealer before making any modifications to your yacht.

The engine and accessories installed on your yacht come with their own operation and maintenance manuals. We strongly urge you to read and understand these manuals before operating the engine and accessories.

### NOTICE

**When storing your yacht please refer to your engine's operation and maintenance manuals.**



## Qualified Maintenance



### WARNING!

To maintain the integrity and safety of your yacht, only qualified personnel should perform maintenance on, or in any way modify: The steering system, propulsion system, engine control system, fuel system, environmental control system, or electrical system.

Failure to maintain these systems (listed in the warning above) as designed could violate the laws in your jurisdiction and could expose you and other people to the danger of bodily injury or accidental death. Follow the instructions provided in this supplement, the *Cruiser & Yacht Owner's Manual*, the engine owner's manual and the accessory instruction sheets included with your yacht.

## Special Care For Moored Boats

Whether moored in saltwater or freshwater, your yacht will collect marine growth on its hull bottom. This will detract from the yacht's beauty, greatly affect its performance and may damage the gelcoat. There are two methods of slowing marine growth:

- Periodically haul the yacht out of the water and scrub the hull bottom with a bristle brush and a solution of soap and water.
- The hull below the waterline was painted with anti-fouling paint by the factory. Occasionally you will need to re-paint it with a good grade of anti-fouling paint.

### NOTICE

- To help seal the hull bottom and reduce the possibility of gelcoat blistering on moored yachts, we recommend the application of an epoxy barrier coating, such as INTERLUX, *Interprotect 2000E/2001E*. The barrier coating should be covered with several coats of anti-fouling paint.
- Many states regulate the chemical content of bottom paints in order to meet environmental standards. Check with your local dealer about recommended bottom paints, and about the laws in effect in your area.

## Sacrificial Anodes (Zinc Plates)

Your yacht is equipped with sacrificial anodes (zinc plates) to protect underwater metal parts from excessive deterioration. Check the zinc plates regularly and replace them if they have deteriorated more than 70%. There are many factors that affect the rate at which zinc plates deteriorate, including:

- Water temperature
- Salinity
- Water pollution

Stray current from your yacht or the dock may cause complete deterioration of the zinc plates in just a few weeks. If there is rapid zinc deterioration, measure electrolytic corrosion around your yacht with a corrosion test meter. If zinc plates are not bonded correctly, they will not provide protection.

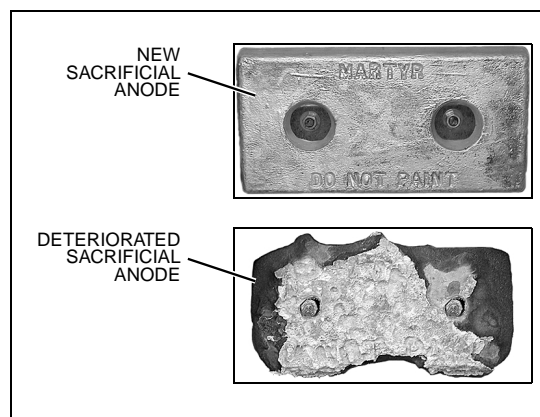

### NOTICE

Do not paint between the zinc and the metal surface it contacts and do not paint over the zincs.

## Carbon Monoxide (CO)

 **DANGER!**



***CARBON MONOXIDE POISONING HAZARD!***

**Carbon monoxide gas (CO) is colorless, odorless, and extremely dangerous. All engines, generators, and fuel burning appliances produce CO as exhaust. Direct and prolonged exposure to CO will cause BRAIN DAMAGE or DEATH.**

**Signs of CO poisoning include:**

- **Headache**
- **Nausea**
- **Dizziness**
- **Drowsiness.**

- CO poisoning causes a significant number of boating deaths each year.
- Called the "silent killer", CO is an extremely toxic, colorless, odorless and tasteless gas.
- Breathing CO blocks the ability of your blood to carry oxygen.
- The effects are cumulative, even low levels of exposure can result in injury or death.

Factors increasing the effects of CO poisoning include:

- Age
- Smokers or people exposed to high concentrations of cigarette smoke
- Consumption of alcohol
- Lung disorders
- Heart problems
- Pregnancy

**Sources of CO**

**Sources of CO include:**

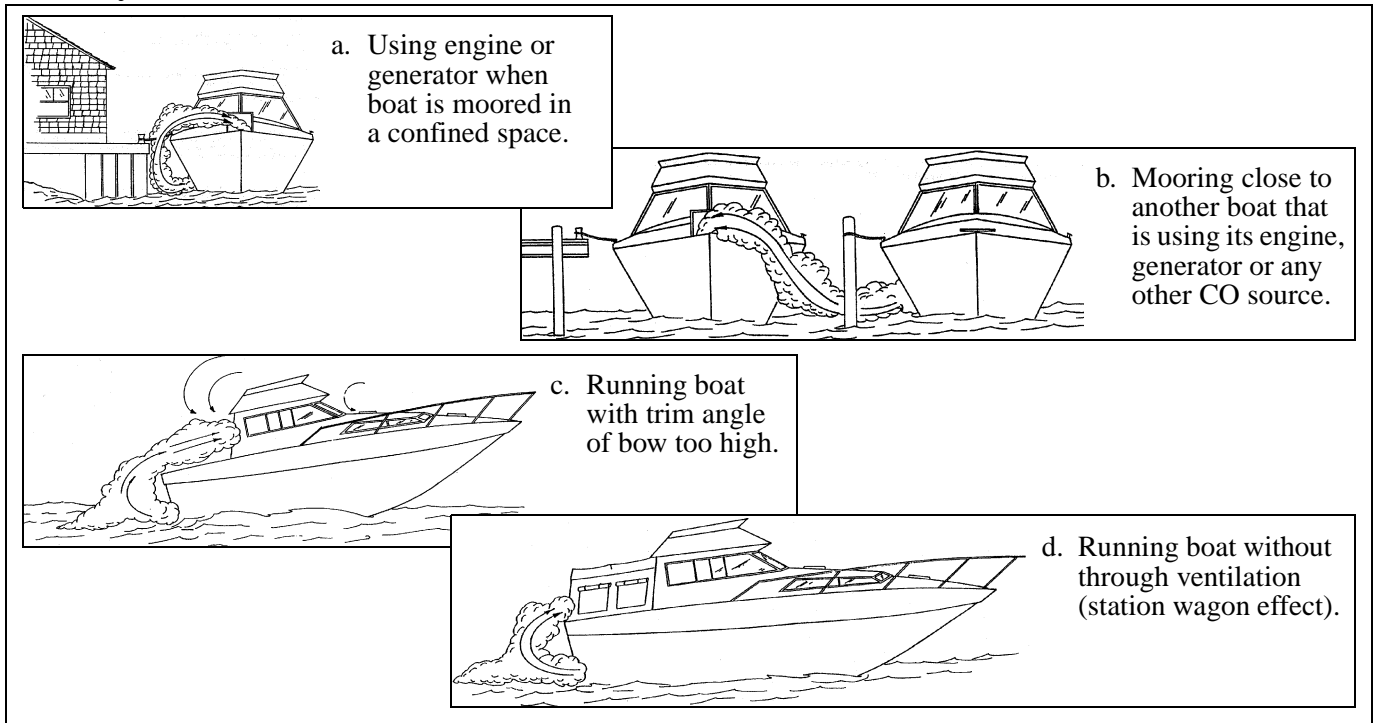

**To correct stationary situations (a) and/or (b):**

- Close all windows, portlights and hatches.
- If possible, move your yacht away from source of CO.

**To correct running situations (c) and/or (d):**

- Trim bow down.
- Open windows and canvas.
- When possible, run yacht so that prevailing winds will help dissipate exhaust.

**IMMEDIATELY** take corrective action if CO is detected (see, *Carbon Monoxide Alarm System*, below).

**Carbon Monoxide Alarm System**

Your yacht may feature a carbon monoxide (CO) alarm system. **DO NOT DISCONNECT THE ALARM SYSTEM.** Read and understand the manufacturer’s instructions for your CO alarm system. If you did not receive an instruction manual, call (800) 383-0269 and one will be mailed to you. If your yacht is not equipped with a carbon monoxide alarm, consider purchasing one from your dealer or marine supply store.

**What To Do If Carbon Monoxide Is Detected**

- Immediately ventilate and evacuate any enclosed spaces that are occupied by people and reset your CO alarm.
- Immediately move anyone showing any symptoms of CO poisoning into fresh air. See a doctor if any symptoms persist. If the person is unconscious, immediately administer oxygen or CPR and call for emergency help.

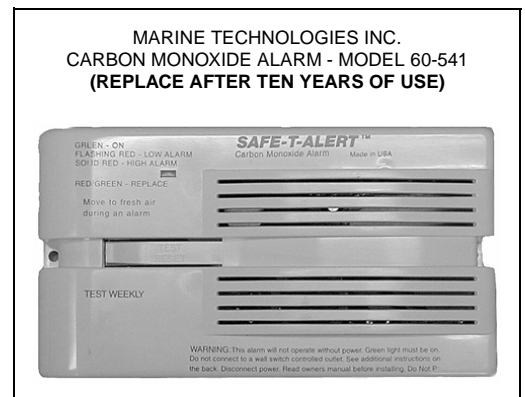

## Yacht Lifting



### WARNING!

**PERSONAL INJURY and /or PRODUCT OR PROPERTY DAMAGE HAZARD!**

- Lift slings may slip on the hull. Avoid serious injury or death by securing the slings together before lifting.



### CAUTION!

**PRODUCT OR PROPERTY DAMAGE HAZARD!**

- When lifting any boat, always use a spreader bar. The spreader bar must be equal to the width of the boat at the lifting point.

- Always follow the lift equipment's instructions and requirements.
- If water is present in the bilge, pump the water out of the bilge areas *before* lifting your yacht. Water in the bilge can shift and change the balance of the load.

### Lifting Sling Positions

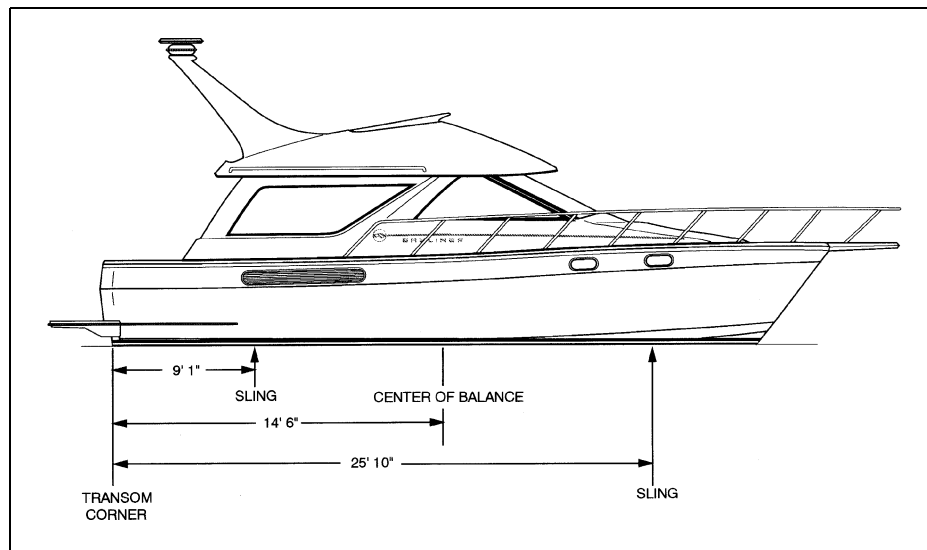

When lifting your yacht, position the lifting slings at the port and starboard sling label positions as shown in the illustration above.

# CHAPTER 2: COMPONENTS / SYSTEMS

## Hull Exterior Hardware & Drains

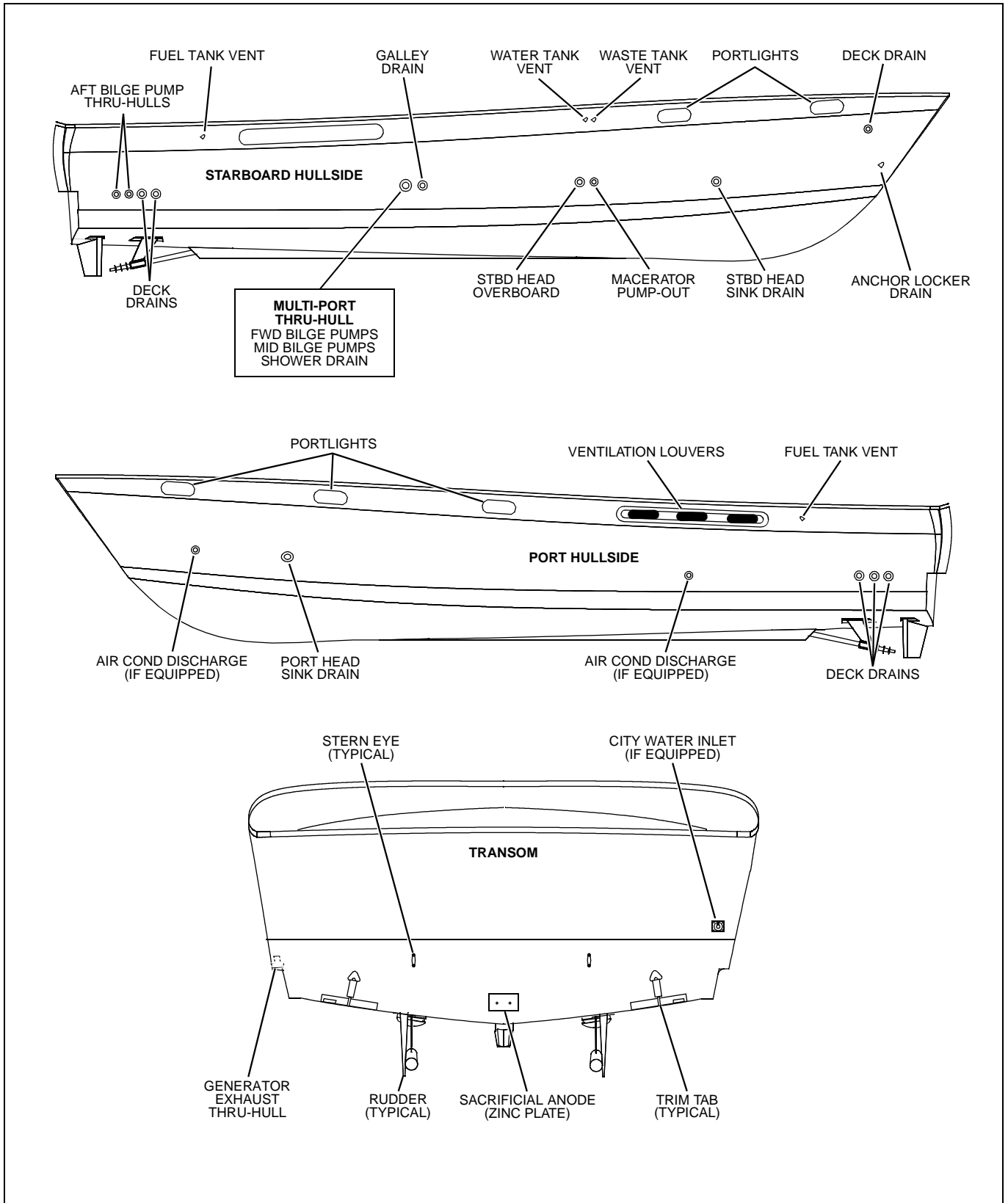

## Deck Equipment

### Deck Fill & Pump-out Locations

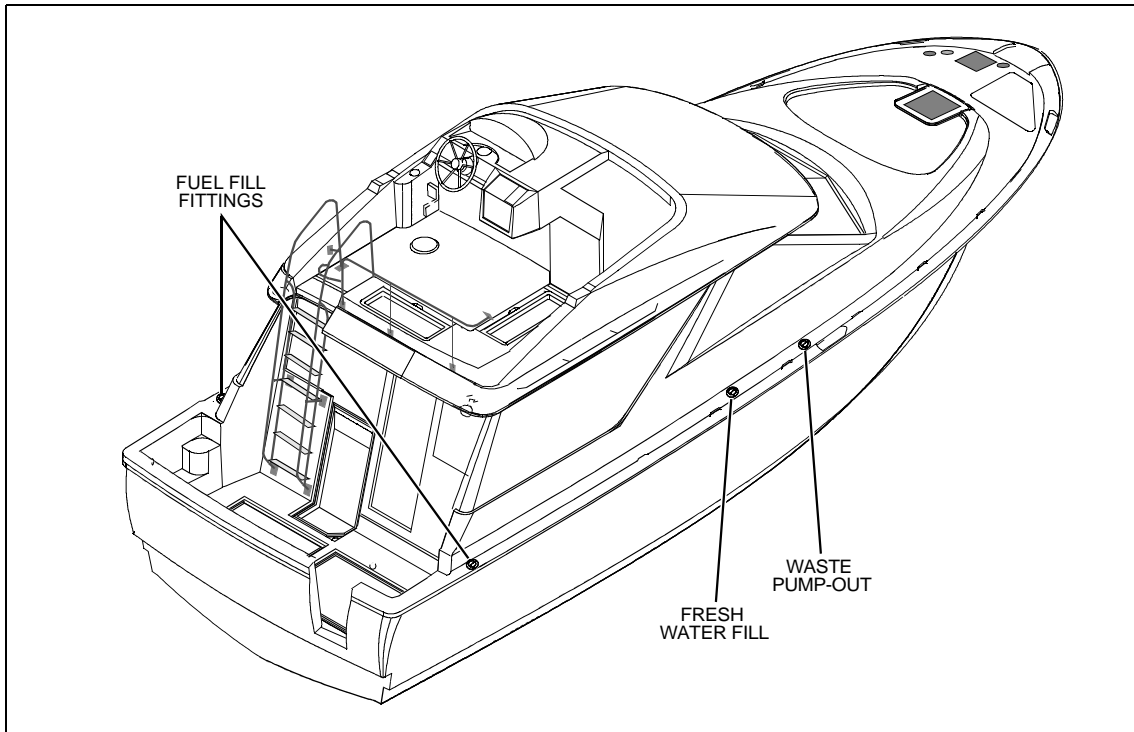

### Anchor Windlass

Before using the anchor windlass, read the windlass manual included in your yacht's owner's packet and observe the following:

- To haul the anchor, use engine power (*not* the windlass) to move the boat to, and directly over the anchor.
- Disengage the anchor from the bottom by pulling it *straight up* with the windlass. *Do not* pull the boat to the anchor using the windlass or continue to operate the anchor windlass if it stalls or is overloaded.

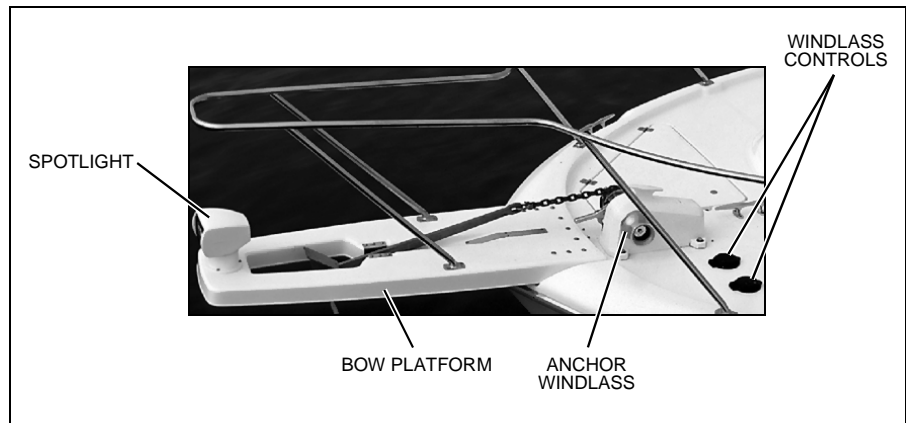

### Windshield Wipers

The windshield wiper fluid bottle can be accessed through the galley floor cut-out. Wiper blades must be replaced when they become worn or deteriorate due to weathering. Replace wiper blades using 28" blade refills. Instructions for replacing the wiper blades can usually be found on the blade replacement package.

# Helm Features

## Command Bridge Helm

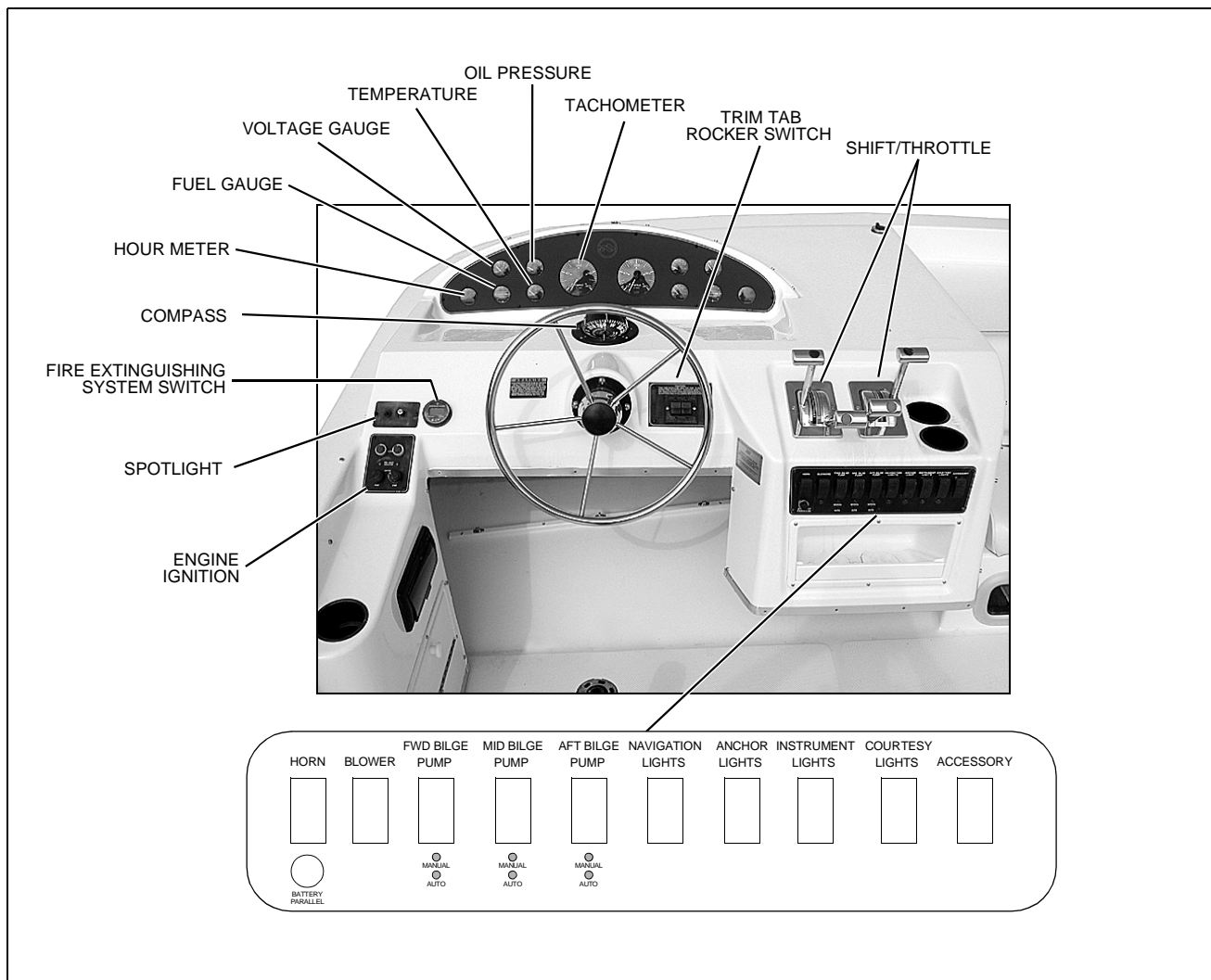

**Lower Helm**

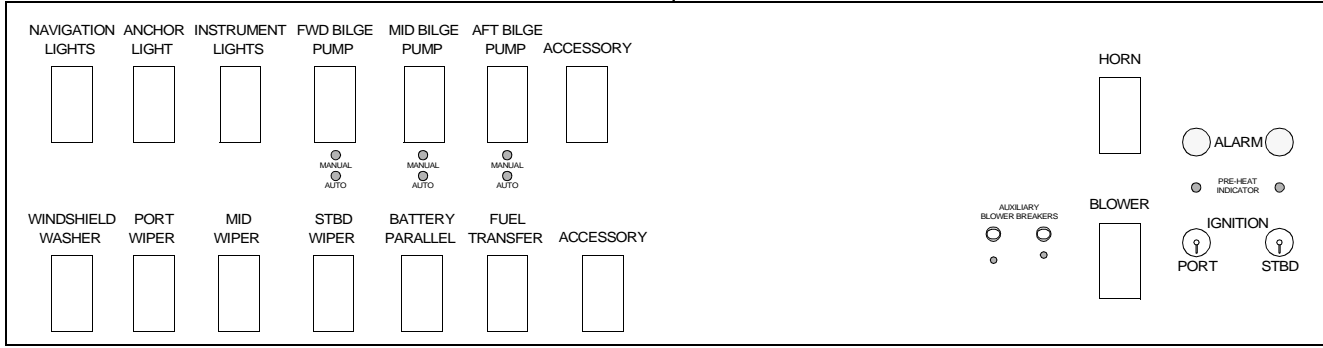
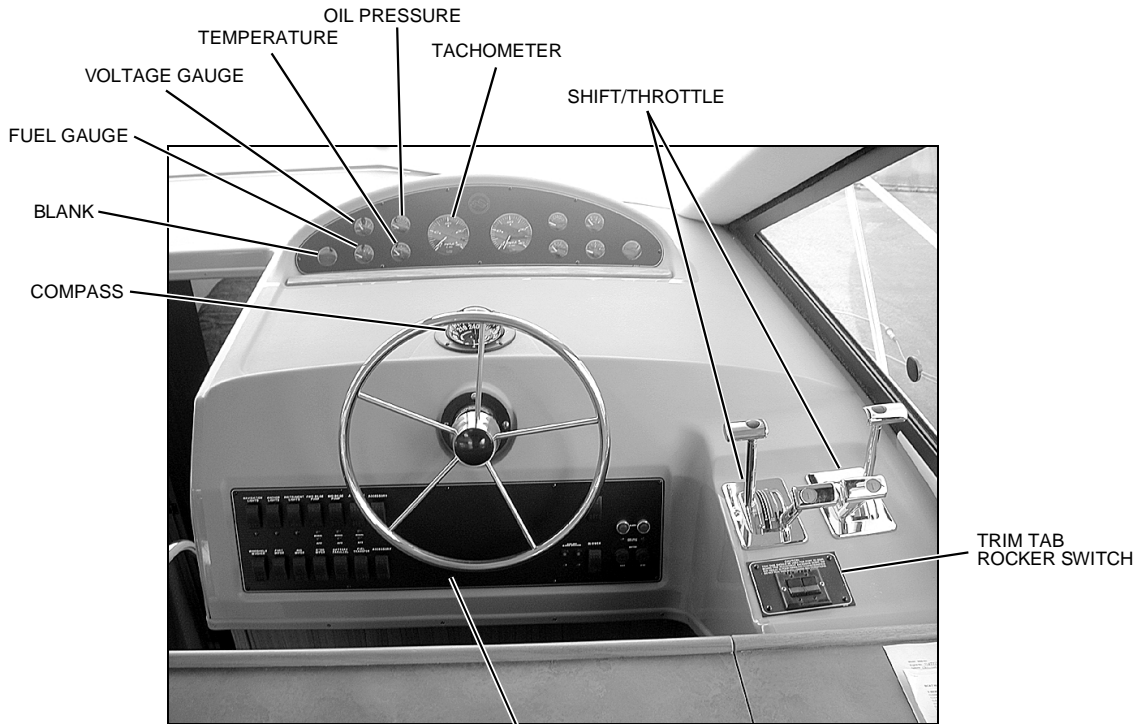



## Navigation & Communication Equipment

The owner's packet contains manuals for all navigation & communication equipment installed on your yacht. Thoroughly read and understand these manuals before using these systems for the first time and observe the following:

### **VHF Radio**

The VHF radio can be used to access weather reports, summon assistance or contact other vessels as permitted by the FCC (Federal Communications Commission). Contact the FCC for licensing, rules and regulations concerning VHF radio usage.

### **Depth Finder**

The depth finder provides you with measurements of water depth beneath the boat.



### **WARNING!**

- **Do not use the depth finder as a navigational aid to prevent collision, grounding, boat damage or personal injury.**
- **When the boat is moving, submerged objects will not be seen until they are already under the boat. Bottom depths may change too quickly to allow time for the boat operator to react. If you suspect shallow water or submerged objects, operate the boat at very slow speeds.**

### **Compass**

Your yacht is equipped with a compass at each helm station. Carefully read and follow the manufacturer's calibration and operating instructions provided your owner's packet.

### **NOTICE**

**Compass accuracy can be affected by many factors. Have a qualified technician calibrate your compass. Make sure the technician gives you a deviation card which shows the corrections to apply in navigational calculations. Keep a copy of the deviation card at each helm.**

**Radar/Plotter (If Equipped)**

Your yacht may feature a radar/plotter system at the lower helm. Radar displays the position, size, and distance of objects around your yacht. The radar/plotter system will *assist* you in navigation and collision avoidance.

**WARNING!**

**Radar is meant to help the navigator, not replace him/her. The operator is responsible for keeping a visual look-out for possible collision situations. No single navigation aid (including this radar) should be relied upon as the only method for navigating your yacht.**

**NOTICE**

**The radar system is only an aid to navigation. It's accuracy can be affected by many factors, including equipment failure or defects, environmental conditions & improper handling or use.**

**Global Positioning System (GPS) (If Equipped)**

Your yacht may feature a GPS system at the lower helm. GPS receivers provide reliable and accurate position data, anywhere in the world.

**WARNING!**

**The GPS system should not be relied upon as the only aid to navigation. A qualified operator must monitor the GPS system at all times and keep look-out for other marine traffic and possible collision situations.**

**NOTICE**

**The GPS system is only an aid to navigation. It's accuracy can be affected by many factors, including equipment failure or defects, environmental conditions & improper handling or use.**

**Autopilot (If Equipped)**

Your yacht may feature an autopilot system which can be turned on at the upper helm station. The autopilot will *assist* you in maintaining the chosen heading of your yacht.

**WARNING!**

**Never leave the helm while the autopilot system is on! A qualified operator must monitor the autopilot system at all times and keep lookout for other marine traffic and other hazards.**

**NOTICE**

**The autopilot system is only an aid to navigation. It's accuracy can be affected by many factors, including equipment failure or defects, environmental conditions & improper handling or use.**

## Navigation & Interior Lights

Read and understand the navigation light section of the *Cruiser & Yacht Owner's Manual*. The navigation and interior lights installed on your yacht are of top quality, but they may fail occasionally for various reasons:

1. There may be a blown fuse - *replace the fuse*.
2. The bulb may be burned out - *carry spare bulbs for replacement*.
3. A wire may be damaged or loose - *repair as required*.
4. The bulb base may be corroded - *clean the base and coat it with non-conductive electrical lubricant*.



### CAUTION!

- **Avoid the storage of gear where it would block navigation lights from view.**
- **Be conservative in the use of battery power. Prolonged use of cabin interior lights (overnight) will result in a drained battery.**

### Spotlight

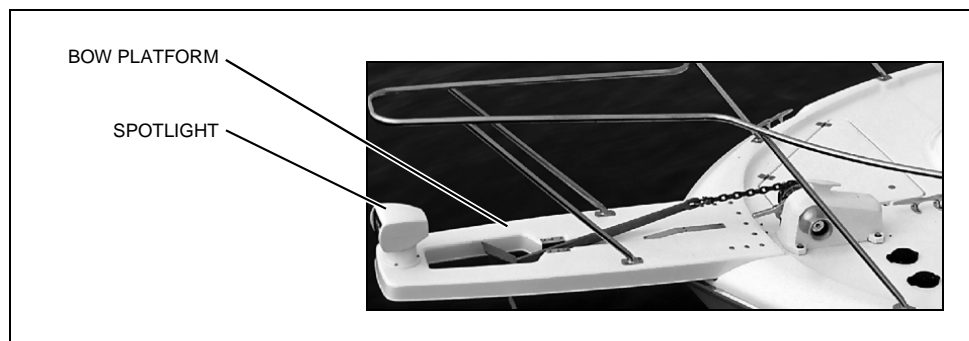

The spotlight is located on the bow platform and can be controlled from the upper helm station. Read the spotlight instructions included in your yacht's owner's packet.

## Controls

### Steering System

Your yacht is equipped with a manual hydraulic steering system. This system is not the same as a car's power steering system.

- A rhythmic pulsing when turning the wheel is a characteristic of the pump and is *not* a malfunction. Also, when coming off a hard-over position, resistances may be felt, followed by a distinct sound. This is a normal situation resulting from the release of the system's check valve.
- The fluid reservoir for the hydraulic steering system is located on the aft wall of the machinery compartment. Check the fluid levels and pressure regularly.

### Rudder Stuffing Gland

The rudder stuffing gland is part of the assembly where the rudders emerge from the bottom of the boat. It is very similar to the propeller shaft stuffing box and will require the same maintenance. Since it does not receive the same wear as the propeller shaft, repacking is seldom required. This shaft stuffing gland should not leak any water.

### Trim Tabs

WARNING!

**LOSS OF CONTROL HAZARD!**

**Improper use of trim tabs will cause loss of control!**

- *Do not allow anyone unfamiliar with trim tabs to operate them.*
- *Do not use trim tabs in a following sea as they will cause broaching or other unsafe handling characteristics.*
- *Do not use trim tabs to compensate for excessive unequal weight distribution.*

The trim tabs may be used to help keep your yacht level at cruising speeds. The trim tabs are controlled by two rocker switches at the helm. Before using the trim tabs read and understand the trim tab operation manual included in your yacht's owner's packet.

Observe the following:

- Once cruising speed is reached, the port or starboard trim switch may be used (one at a time) to level the yacht.
- Perform trim tab adjustment with several short touches to the switch rather than one long one.
- After each short touch allow several seconds for the hull to react.
- The trim tab hydraulic fluid reservoir is located on the aft wall of the machinery compartment. The fluid level must be checked periodically (at least once a year) and refilled as necessary.

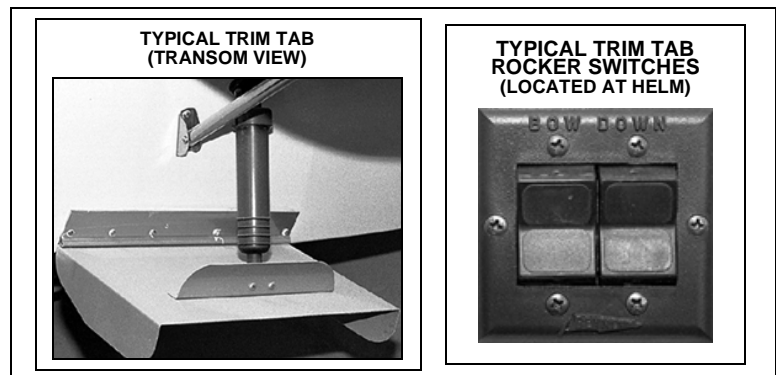

## Propulsion

### Engines

The owner's packet contains detailed engine manuals. Read and understand these manuals *before* using or working on the engines.

### Engine Room Ventilation System

The bilge blowers remove fumes from the engine compartment. Fresh air is drawn into the compartment through the deck vents.

To make sure the engine compartment is ventilated with fresh air, run the bilge blower:

- For at least four minutes before starting the engines or generator.
- During starting.
- Anytime your yacht is running below cruising speed.

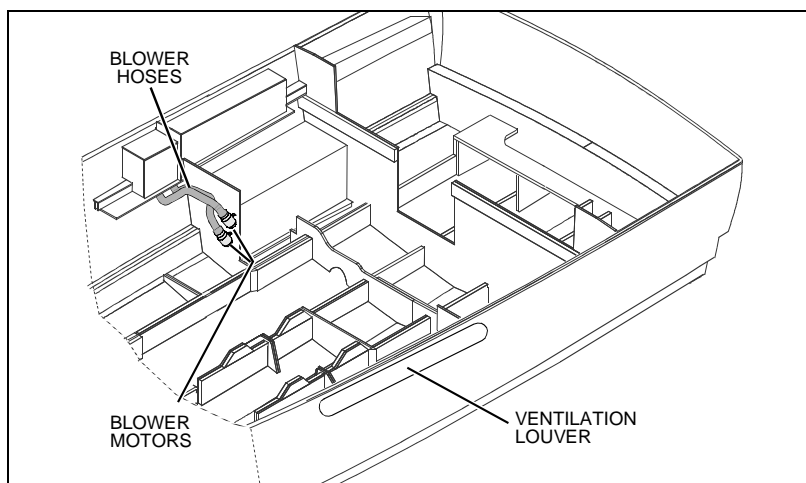

**⚠ WARNING!**

**FIRE/EXPLOSION HAZARD**

- Use of the blower system is **NOT A GUARANTEE** that explosive fumes have been removed.
- If you smell fuel, **DO NOT** start the engines or generator, and **DO NOT** turn on any electrical devices.
- If you smell fuel and the engines and/or generator are already running, **SHUT OFF** the engines and/or generator and **TURN OFF** all electrical devices. Investigate immediately.
- **DO NOT** obstruct or modify the ventilation system.

### Engine Cooling System

The engine cooling system circulates raw water around components and also uses a freshwater heat exchanger on the engine to reduce engine temperature.

- Make sure both engine seawater intake valves (seacocks) are *open* before starting the engines and keep the seacocks *open* while the engines are running.
- Check the cooling system's seawater strainers for leaks and debris every time you use your yacht. For instructions on how to clean the seawater strainers, see the *Seawater System* section of this Supplement.

**⚠ CAUTION!**

**SYSTEM DAMAGE HAZARD!**

- **Open** the engine cooling system seacocks *before* starting the engines.
- The seacocks must remain open while the engines are running.

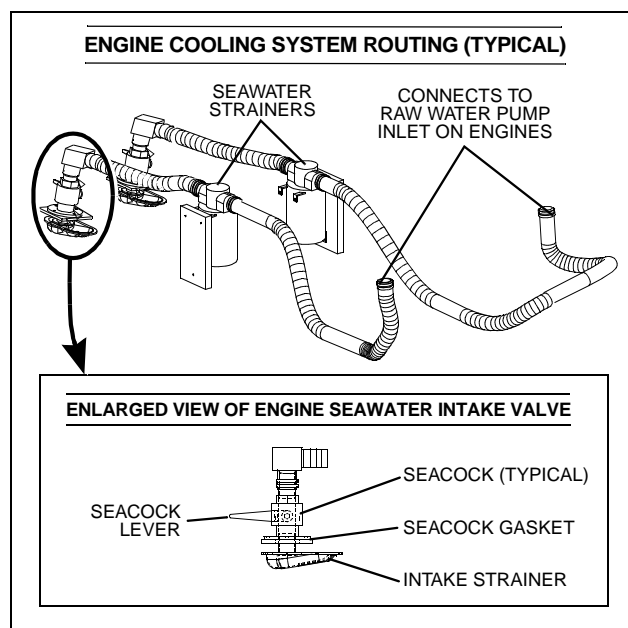

## Exhaust System

⚠ **DANGER!**

CARBON MONOXIDE POISONING HAZARD!

**Leaking engine and/or generator exhaust is a source of dangerous carbon monoxide gas (CO). Check all exhaust systems before each trip.**

- **Look for leaks in exhaust systems of both generator and propulsion engine(s).**
- **Look for discoloration, water leaks, carbon or stains around joints.**
- **Make sure all exhaust clamps are in place and secured.**
- **Make sure ventilation systems work and are not obstructed or restricted.**
- **To reduce risk of CO entering living space(s) make sure gaps are minimized around engine room plumbing, cableways, exhaust system, doors, hatches, and access panels.**

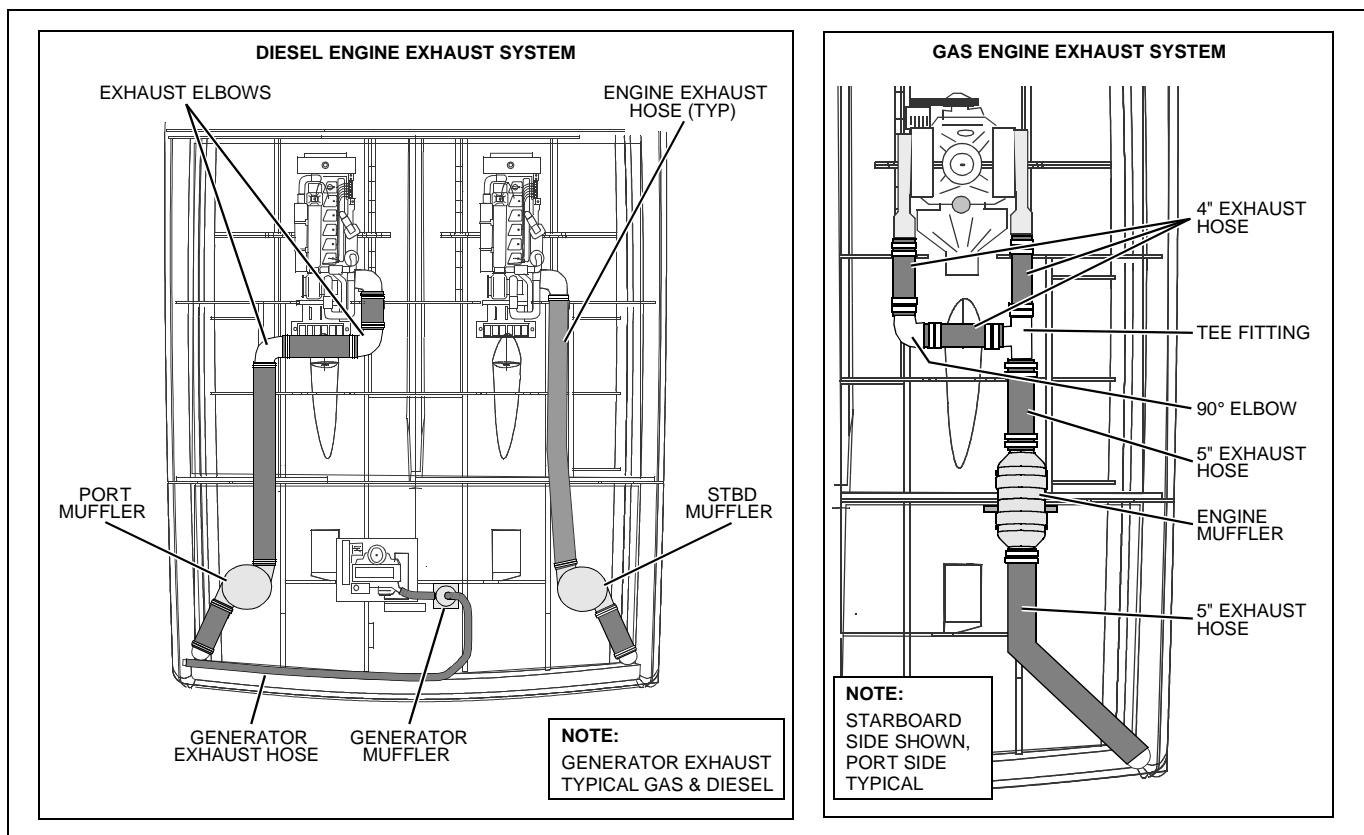



The exhaust system is designed to keep water out of the engines in most sea conditions. However, use care NOT to anchor the stern to sea, and do NOT shut off engines if the seas are too high. Always use good seamanship and consider the sea conditions *before* anchoring or shutting off the engines. Check all of the exhaust system clamps after the first 20 hours. Continue to check the clamps periodically after that.

### Oil Change System (If Equipped)

Your yacht may be equipped with an oil change pump to simplify draining and filling engine and generator oil. See the instructions included in your owner's packet for information on the use of this system.

## Fuel System

 <b>WARNING!</b>	
	<b><i>FIRE/EXPLOSION HAZARD</i></b> - It is very important that the fuel system be inspected thoroughly the first time it is filled and at each subsequent filling.
	The <b><u>Fueling Instructions in the <i>Cruiser &amp; Yacht Owner's Manual</i></u></b> and the <b><u>Fuel Recommendations in the engine operation manual</u></b> must be followed.

 <b>CAUTION!</b>	
Air in the diesel supply system can stop an engine or severely restrict performance. If you suspect air in your diesel fuel lines, refer to your engine operation manual for detailed instructions on how to “bleed” the system.	

 <b>CAUTION!</b>	
Avoid the storage or handling of gear near the fuel lines, fittings and tank.	

Carefully read the Fuel Section of the engine manual included in your yacht's owner's packet. Give special attention to the subject of Fuel Recommendations. Inspect the filters/separators periodically for debris and replaced as needed according to the instructions in your engine manual, generator manual and in the filter literature supplied in your yacht's owner's packet.

### **Fuel Quality**

- The quality of the fuel is very important for good engine performance and long engine life. Fuel must be clean and free of contamination. Keep your fuel tanks full whenever possible. This will reduce the amount of water condensation and reduce the possibility of contamination. Allow for expansion due to warmer temperatures.
- Ask your dealer or local marina about fuel additives that help prevent fungus growth or buildup in your tanks.

### **Fuel Filters & Separators**

Periodically inspect the fuel filters and separators for debris and replace as needed (according to the instructions detailed in your engine manual, generator manual and in the filter literature). The engine fuel filters are located on the forward wall of the engine compartment. The generator fuel filter is located on the forward wall of the machinery compartment.

**Fuel Transfer Pump (Diesel Systems Only)**

The fuel transfer pump is used to pump fuel from one tank to another. The fuel transfer pump switch is located at the upper helm station.



 <b>CAUTION!</b>
<b>ENVIRONMENTAL HAZARD! NEVER transfer fuel into a full (or nearly full) fuel tank. Fuel transferred into a full tank may spill overboard through the tank venting system.</b>

**Anti-siphon Valve (Gas Engines Only)**

An anti-siphon valve is an integral part of the fuel line barb fitting on each fuel tank. These valves are spring loaded and are opened by fuel pump vacuum. If a fuel line ruptures the valve prevents the siphoning of fuel from the tank.

**Fuel Fills & Vents**

- Fuel fills are located on the port and starboard side decks, just aft of the bow rail. Fuel fill caps are marked Diesel" or "Gas". If you have trouble filling a fuel tank, check to see that the fuel fill and vent lines are free of obstructions and kinks.
- Fuel vents are located in the hull below the same general area as the fill.

 <b>WARNING!</b>
 <b>FIRE, EXPLOSION AND OPEN FLAME HAZARD!</b>
<ul style="list-style-type: none"> <li>• It is very important that the fuel system be inspected thoroughly the first time it is filled and at each subsequent filling.</li> <li>• The <u>fueling instructions in the <i>Cruiser &amp; Yacht Owner's Manual</i></u> and the <u>fuel recommendations in the engine operation manual</u> must be followed.</li> </ul>

 <b>CAUTION!</b>
<ul style="list-style-type: none"> <li>• Air in the diesel supply system can stop an engine or severely restrict performance. If you suspect air in the fuel lines, refer to your engine operation manual for detailed instructions on how to <i>bleed</i> the system.</li> <li>• Avoid the storage or handling of gear near the fuel lines, fittings and tank.</li> </ul>

<b>NOTICE</b>
<b>Discharge of oil, oil waste or fuel into navigable waters is prohibited by law. Violators are subject to legal action by the local authorities.</b>



Fuel System Diagrams

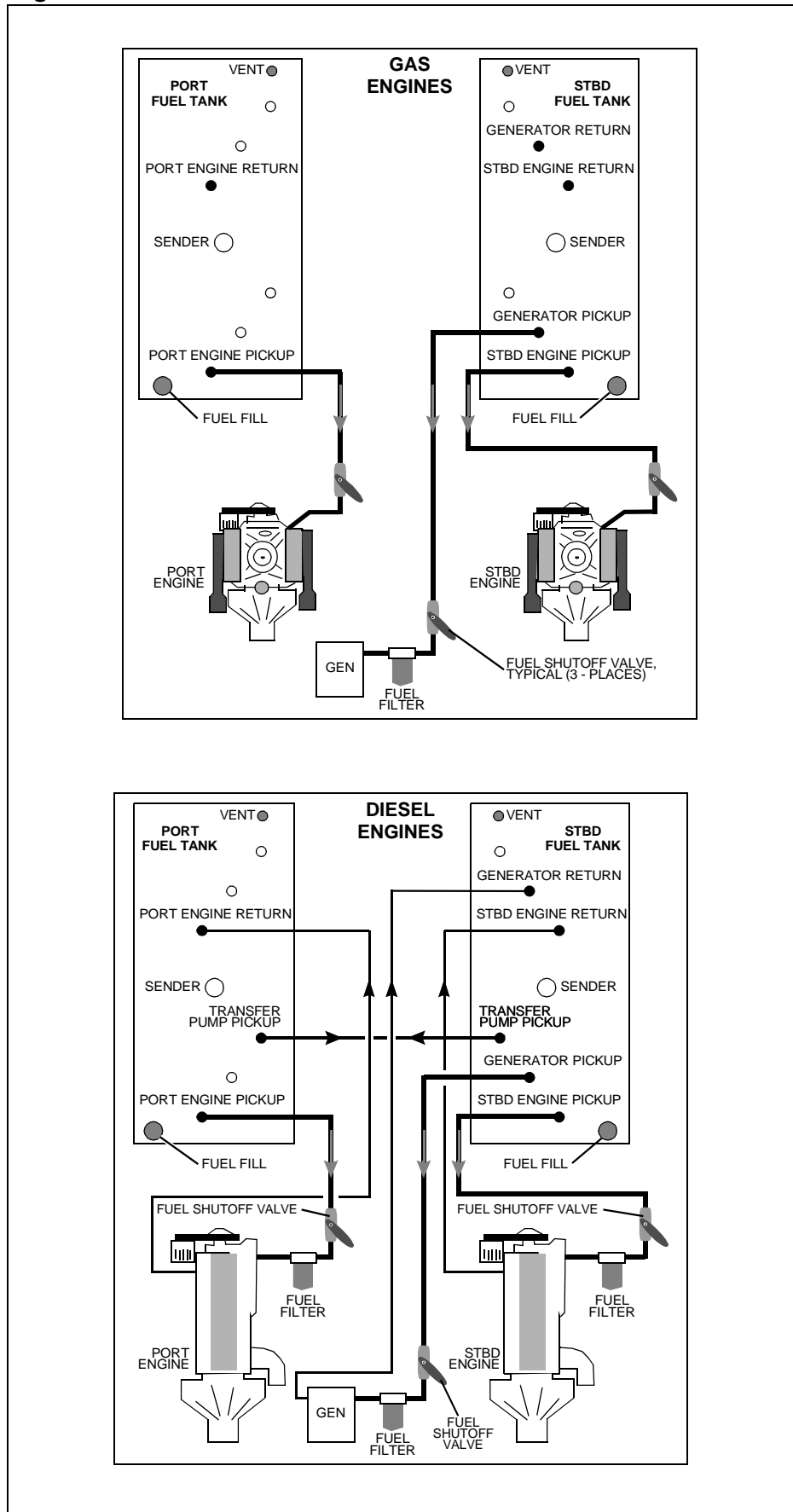

## Shaft-Transmission Alignment

Alignment between the engine transmission output shaft and the propeller is very critical. The alignment has been performed at the factory and was rechecked by the dealer after the boat had been in the water for 48 hours.

- An alignment inspection should be performed by a marine mechanic as part of the routine maintenance program after the initial 30 hours of operation, then every 60 hours and whenever unusual noise or vibration is noticed.
- Shaft-transmission alignment should be performed by a marine mechanic since it requires moving the engine and prop shaft.
- To insure proper alignment after a hallout or dry storage, wait 48 hours after launching before final alignment adjustments by a marine mechanic are made.

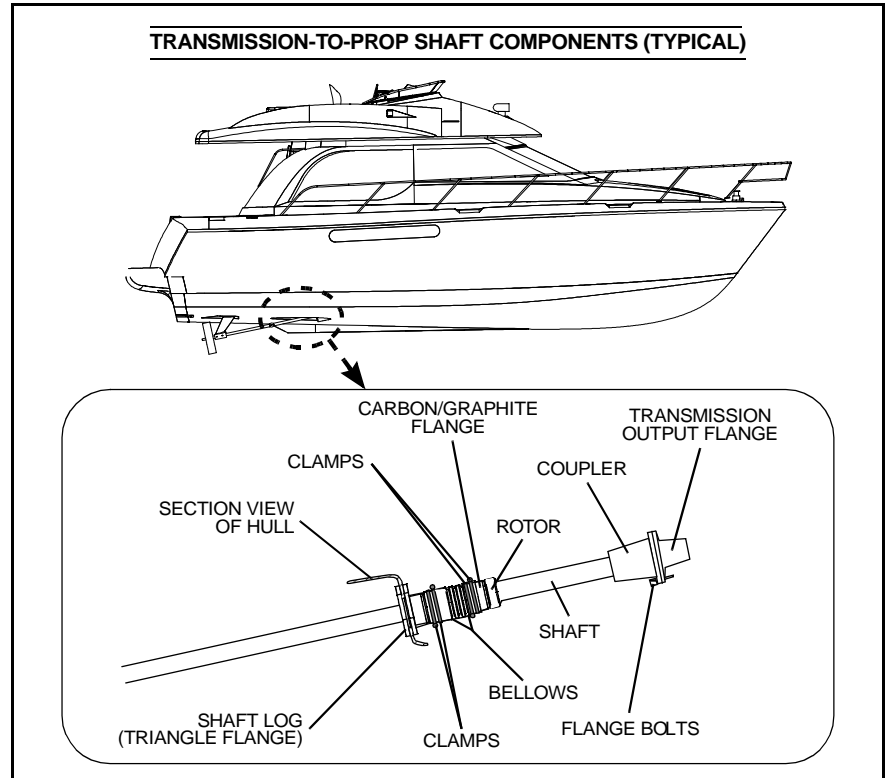

### CAUTION!

#### **SYSTEM DAMAGE HAZARD!**

- **If you suspect a shaft-transmission misalignment, have a qualified mechanic perform an alignment inspection as soon as possible.**
- **Continued use may lead to premature engine, transmission, shaft, shaft seal and/or hull damage!**



### Shaft Log Packless Sealing System

The shaft log packless sealing system's shaft seal is a maintenance-free, watertight seal that doesn't require packing or adjustments.

## Electrical System

Read and understand this section and the Electrical Section of the Cruiser & Yacht Owner's Manual. Wiring diagrams are provided in CHAPTER 3 of this supplement.

**⚠ DANGER!**

**EXTREME FIRE, SHOCK & EXPLOSION HAZARD!**

- To minimize the risks of fire and explosion, *never* install knife switches or other arcing devices in the fuel compartments.
- *Never* substitute automotive parts for marine parts. Electrical, ignition and fuel system parts were designed and manufactured to comply with rules and regulations that minimize risks of fire and explosion.
- *Do not* modify the electrical systems or relevant drawings.
- Only qualified personnel should install batteries and/or perform electrical system maintenance.
- Make sure all battery switches are in the *off* position before performing any work in the engine spaces.

**⚠ WARNING!**



- 1
- 2  
4 min
- 3



**FIRE, & EXPLOSION HAZARD!**

- Fuel fumes are heavier than air and will collect in the bilge areas where they can be accidentally ignited. Visually and by smell (sniff test), check the engine and fuel compartments for fumes or accumulation of fuel. Always operate the bilge blowers for at least four minutes prior to engine starting, electrical system maintenance or activation of electrical devices.
- Minimize the danger of fire and explosion by not exposing batteries to open flame or sparks. It is also important that no one smoke anywhere near the batteries.

**⚠ CAUTION!**



**ELECTRICAL SYSTEM DAMAGE HAZARD!**

*Never* disconnect the battery cables while the engine is running since it can cause damage to your yacht's electrical system components.

NOTICE

Electrical connections are prone to corrosion. To reduce corrosion-caused electrical problems, keep all electrical connections clean and periodically coat them with a product specifically designed to control and prevent corrosion.

## 12-Volt DC System

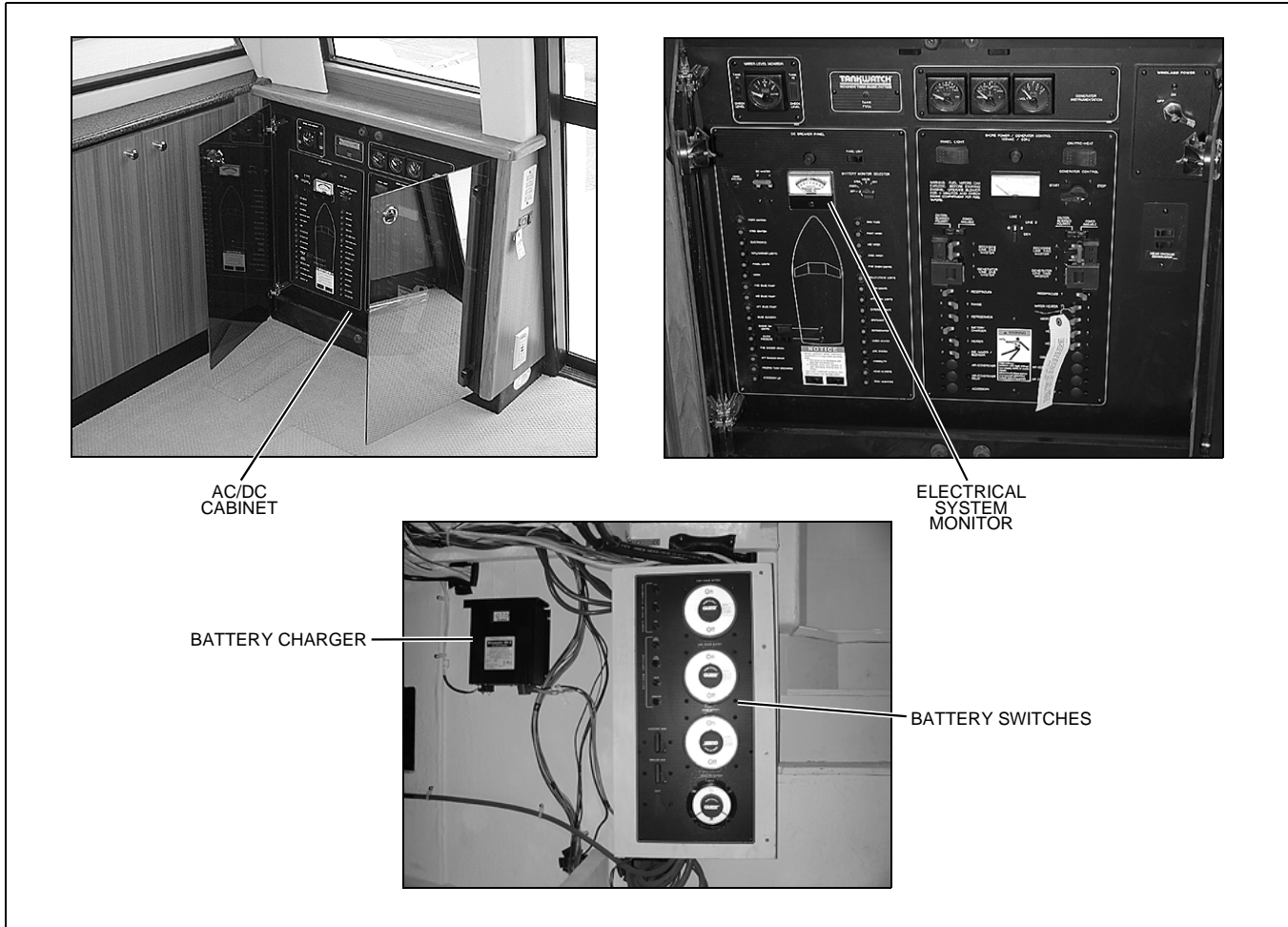

### Fuses and Circuit Breakers

Fuses and circuit breakers for main accessory power, float switches and windlass power are located in the AC/DC cabinet (starboard side of salon). Electronic's power is provided at the upper helm station. Some equipment, such as depth finders and shower pumps may have secondary fuse protection at the unit.

### Battery Switches

The battery switches are located inside the engine room and starboard of the cockpit door. A separate rotary battery switch is provided for each battery. In addition, if an engine battery's power is low a parallel switch is provided at each helm to enable you to start the engines using all of the engine batteries.



## CAUTION!

- The parallel switch should be turned on *only* in emergencies.
- *Never* disconnect battery cables or turn off main battery switches while engines are running as this can cause damage to your boat's electrical components.

### **Batteries**

The batteries supply electricity for lights, engine and generator starting, as well as power to turn on accessories. Remove the battery caps and check the electrolyte level every 30 days (more frequently in hot weather). If the zinc plates are exposed, add distilled water until they are covered. Corroded battery terminals can be cleaned with baking soda and water. After cleaning the terminals, coat them with a light film of grease. Make sure all battery connections are tight.

Battery condition can be checked on the “Electrical System Monitor” located in salon on the DC distribution panel (starboard side of the salon). The condition of the accessory battery can be read on the starboard engine voltmeter when the accessory battery switch is in the ON position. The starboard voltmeter will register the accessory battery state even when the engines are shut down and the ignition switches are turned off.

### **Engine Alternators**

The engine alternators will maintain proper charge levels in the engine and accessory batteries (some situations may require running engines at 1200 RPM to initiate charging).

### **Battery Charger**

In addition to the engine alternators, your yacht is equipped with a battery charger. Thoroughly read and understand the battery charger manual, provided in your yacht’s owner’s packet, before using the charger. The battery charger is located inside the engine room, starboard of the cockpit door.



#### **CAUTION!**

**The battery charging systems (alternator and battery charger) installed are designed to charge conventional lead-acid batteries. Before installing gel-cell or other new technology batteries, consult with the battery manufacturer about charging systems requirements.**

## 110-Volt AC System

- The AC system can be energized by shore power or generator power.
- The master circuit breakers, located on the AC panel, provide power source selections to AC powered accessories. Individual breakers *must* be turned on to supply power to the accessories you wish to use.
- This system is designed so that ship's power and shore power sources *cannot* supply power at the same time.
- The AC panel may contain inactive circuit breakers for accessories that are not available for this model yacht.



### CAUTION!

#### ***WATER HEATER DAMAGE HAZARD!***

**Do not energize the water heater electrical circuit until the heater is COMPLETELY filled with water. Even momentary operation in a dry tank will damage the heating elements. Warranty replacements WILL NOT be made on elements or tank damaged in this manner.**

### NOTICE

**Whether using shore power or generator power, the simultaneous use of several AC components can result in an overloaded circuit. It may be necessary to turn off one or more accessories in order to use another accessory.**

## Shore Power



### DANGER!



#### ***FIRE, EXPLOSION & SHOCK HAZARD!***

- **DO NOT** alter shore power connectors and use only compatible connectors.
- **Before connecting or disconnecting the shore power cord to your yacht, make sure all breakers and switches on the AC master panel are turned OFF.**
- **To prevent shock or injury from an accidental dropping of the “hot” cord into the water, ALWAYS attach the shore power cord to the boat inlet first; then to the dockside connection. When disconnecting from shore power, disconnect the shore power cord from the dockside connection first.**
- **NEVER** leave a shore power cord connected to the dockside connection only.
- **Only use shore power cords approved for marine use. NEVER use ordinary indoor or outdoor extension cords that are not rated for marine use.**



### WARNING!



#### ***SHOCK & ELECTRICAL SYSTEM DAMAGE HAZARD!***

- **Monitor the polarity indicator lights EVERY TIME you connect to shore power.**
- **When connecting to shore power and you encounter a reversed polarity light (RED colored), DO NOT energize the main breaker switches. Instead, IMMEDIATELY disconnect the shore power cord (ALWAYS from the dockside receptacle first) and notify marina management.**

## ! WARNING!



### **SHOCK & ELECTRICAL SYSTEM DAMAGE HAZARD!**

- Periodically check the shore power cord(s) for deterioration or damage. NEVER use damaged or faulty cords since the danger of fire and electrical shock exists.
- DO NOT pinch shore power cords in doors or hatches, or coil the shore power cord too tightly since these situations can generate enough heat to result in a fire.
- If a shore power cord accidentally becomes immersed in water, THOROUGHLY dry the blades and contact slots before reusing.



## CAUTION!



### **ELECTRICAL SYSTEM DAMAGE HAZARD!**

- NEVER connect dockside power to your yacht outside North America unless you have purchased the international electrical conversion option.
- The simultaneous use of several AC components can result in an overloaded circuit. It may be necessary to turn off one or more accessories in order to use another accessory.
- Use double insulated or three-wire protected electrical appliances whenever possible.

## NOTICE

Some dockside installations may be rated less than 30 amps, therefore, you may need to purchase lower amp adapters. Whenever a lower amp adapter is used, however, there will be a corresponding drop in supplied power from the dockside system.

- Shore power receptacles are located outside the cabin on the starboard side.
- Shore power receptacles are rated either 30 or 50 amps with appropriate power cords furnished.
- Since not every shore installation has 30 amp service, we recommend that 15 and 20 amp adapters be purchased. However, whenever 15 or 20 amp adapters are used, there will be a corresponding drop in supplied power from the dockside system.

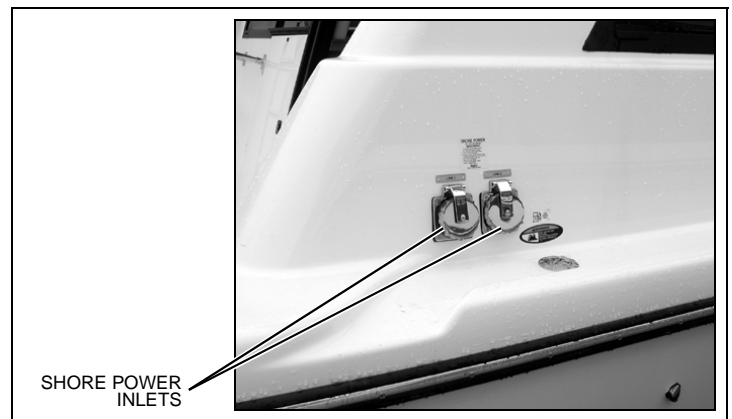

### **Connecting To Shore Power**

1. Turn OFF all breakers and switches on the AC master panel.
2. Attach the shore power cord to the boat inlet first then to the dockside outlet (see warning on previous page).
3. Monitor the AC panel's polarity indicator lights, located below the line master breakers, as follows:
  - A *green* light illuminating after the power cord is plugged into the dockside outlet indicates acceptable electrical power. You may turn on the master breaker switch.
  - A *red* light, however, indicates reversed polarity, which could cause electrical system damage and possibly electrical shock injuries. In this case, *do not* turn on the master breaker switch (see warning on previous page).
4. Switch the "Line 1 Dockside Master" ON.
5. Switch the "Line 2 Dockside Master" ON.
6. Turn ON the individual component breakers as required.

## Generator Power

⚠ **DANGER!**



**CARBON MONOXIDE POISONING HAZARD!**

Generators are a source of dangerous carbon monoxide gas (CO). Check the generator exhaust system for leaks before each use.

Before using your generator read the manufacturer's instructions included in the owner's packet.

### Always observe the following:

- Follow instructions in the generator manual for pre-start checks and break-in procedures.
  - The starter switch is located on the AC electrical panel (located on the starboard side of salon).
1. Before starting the generator, open the generator seawater intake valve (seacock) located in the machinery compartment. The seacock must remain open while the generator is running. Check the seawater strainer often for leaks and/or debris.
  2. Run the bilge blowers for a minimum of four minutes before starting the generator. Leave the blowers on while the generator is running unless the yacht is underway at cruising speed.
  3. **Diesel generator;** turn the pre-heat switch to the ON position and allow one minute for pre-heating.  
**Gas generator;** simultaneously press the oil pressure button and turn the starter switch until the generator starts.
  4. Turn the Starter switch to start, releasing it as soon as the generator starts. NEVER operate the starter for more than 30 seconds. If the generator does not start, wait at least 30 seconds before another start attempt is made.

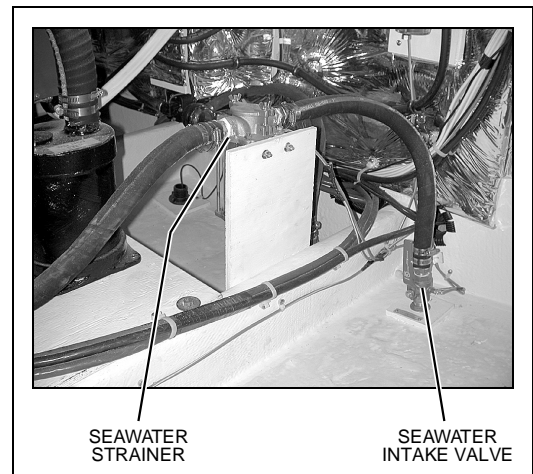

- Fuel to run the generator is supplied from the starboard fuel tank (see the fuel system diagrams in the next section).
- In addition to servicing the filters attached to the diesel generator. Service the filter/separator located near the fuel line valves as described in the manufacturer's instruction manual.
- The coolant mixture installed at the factory consists of equal parts of water and antifreeze (Ethylene Glycol).
- Oil pressure and water temperature gauges are above to the AC panel and monitor the engine functions of your generator. Gauge readings during normal generator operation are: Temperature between 165° to 195° F; Oil pressure between 35-55 PSI.

To energize the AC system under generator power; switch the generator master circuit breakers to ON and then turn on each individual component breaker as required.

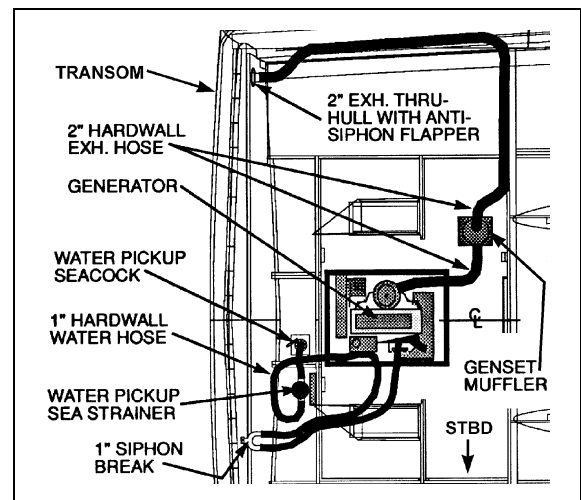



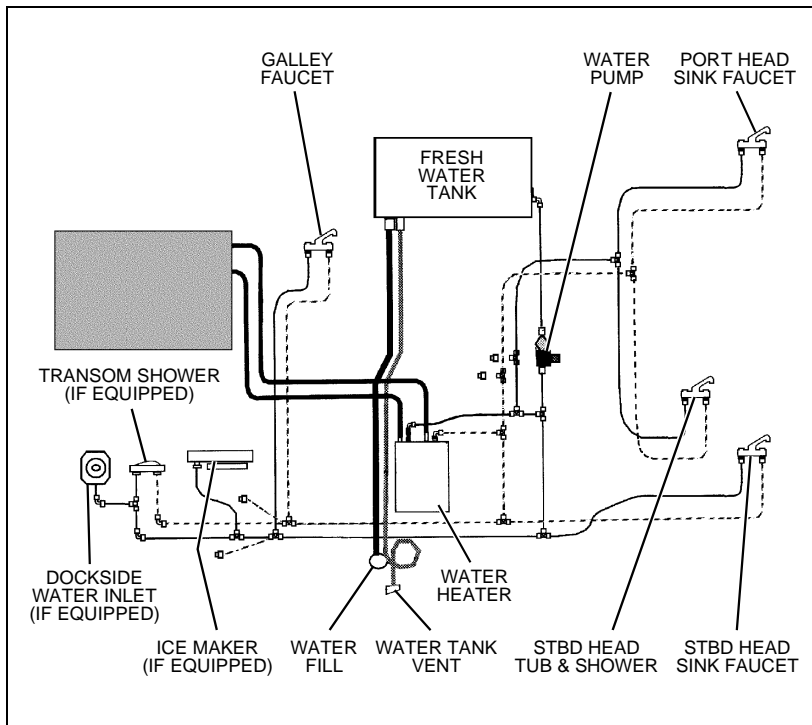

## Fresh Water System

Inspect and clean the water filter often. The water filter is located in the accessory room (access through the mid-ship state room).

Unless your yacht is connected to a dockside water supply, the water pump's DC breaker must be ON to use the freshwater system.

The water tank is equipped with a water level indicator in the AC/DC cabinet. It is always a good idea to top off the water tank at every opportunity to avoid the possibility of running short of fresh water.

The water fill is located on the starboard side of the deck and the water tank is located under the bed in the mid-ship state room.

When your yacht is to be left unattended for long periods of time, pump the water tank dry to prevent stored water from becoming stagnant and distasteful. Should it become necessary to disinfect the fresh water system, ask your dealer about treatment systems available and follow the manufacturer's instructions.

### 110-Volt Water Heater

The water heater is located on the starboard side of the accessory room, forward of the engine. Access is gained through the mid-ship state room. Read the manufacturer's instruction manual supplied in your owner's packet.

**⚠ WARNING!**

**⚠ SCALDING HAZARD!**  
Water heated by the water heater can reach temperatures hot enough to scald the skin.

**⚠ CAUTION!**

**WATER HEATER DAMAGE HAZARD!**

- **DO NOT** turn on the AC water heater electrical circuit until the heater is *completely* filled with water. Even momentary operation in a dry tank will damage the heating elements. Warranty replacements *will not* be made on elements or tank damaged in this manner. The tank is full if water flows from the tap when the hot water is turned on in the galley.
- When the possibility of freezing exists, drain the water heater (power turned *off*).

**NOTICE**

**If your yacht is connected to shore power or generator power, but the water heater is not working:**

- Make sure the water heater circuit breaker on the AC panel is switched ON.

**If the circuit breaker on the AC panel is ON, but the water heater is still not working:**

- Consult with your dealer about checking the "push to reset" circuit breaker located on the water heater.

### Transom Shower (If Equipped)

Your yacht may feature a freshwater transom shower. The transom shower is located on the starboard side of the cockpit, just inside the transom entry gate (see photo on right). Read the manufacturer's instruction manual, provided in your boat's owner's packet.

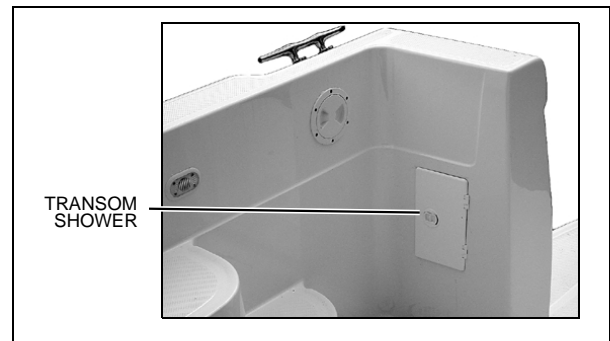

### Gray Water Drain System

- Gray water from the sinks and showers drains overboard.
- The sinks are above the water line and have gravity drains.
- The port and starboard showers are below the waterline and are drained by a sump pump.
- The sump pump, controlled by a float switch, automatically turns on when drain water fills the sump pump box (A) to a preset level.
- The sump pump automatically shuts off after the showers have drained.

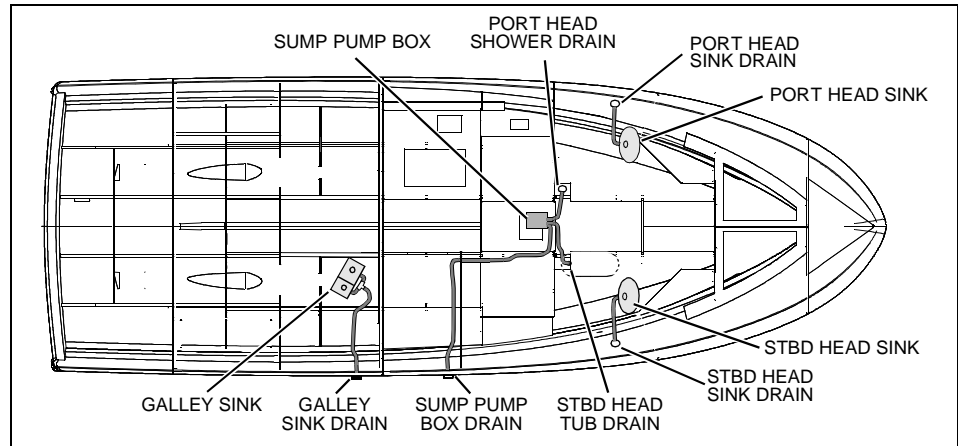

### Sump Box Cleaning

The sump box, filter, and pump should be periodically cleaned of debris as follows:

1. Access sump pump box (A) by removing hatch at bottom of stairs.
2. Remove cover screws (B) and cover (C).
3. Remove any debris from box and filter.
4. Clean sump pump as outlined in Bilge Pump section of this *Supplement*.

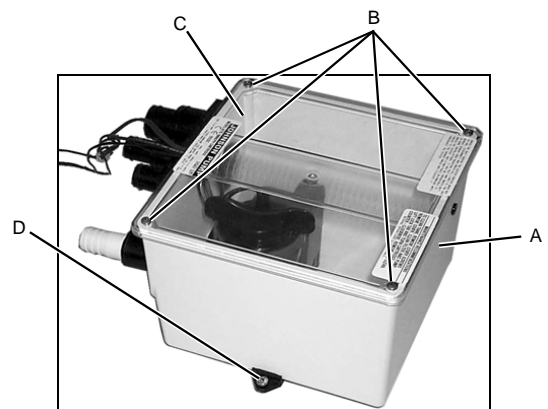
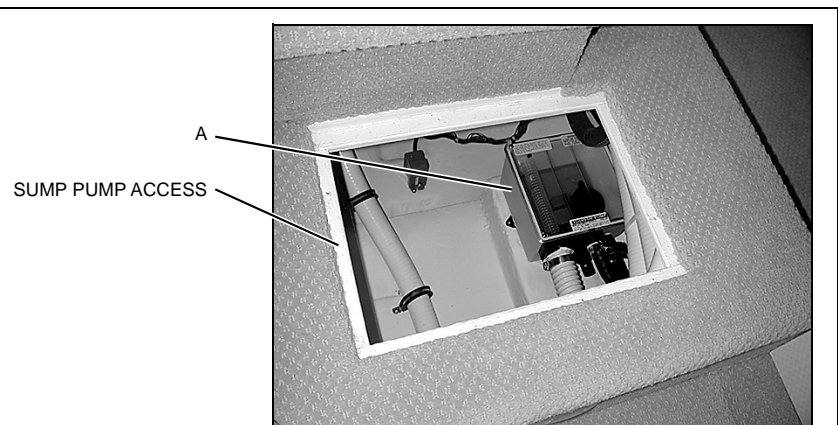

### Sump System Winterizing

Drain the sump pump system in the winter months when not in use.

1. Disconnect and drain all lines to unit.
2. Remove screws from mounting feet (D) and drain system.
3. Reinstall screws in mounting feet and reconnect system.

## Seawater Systems

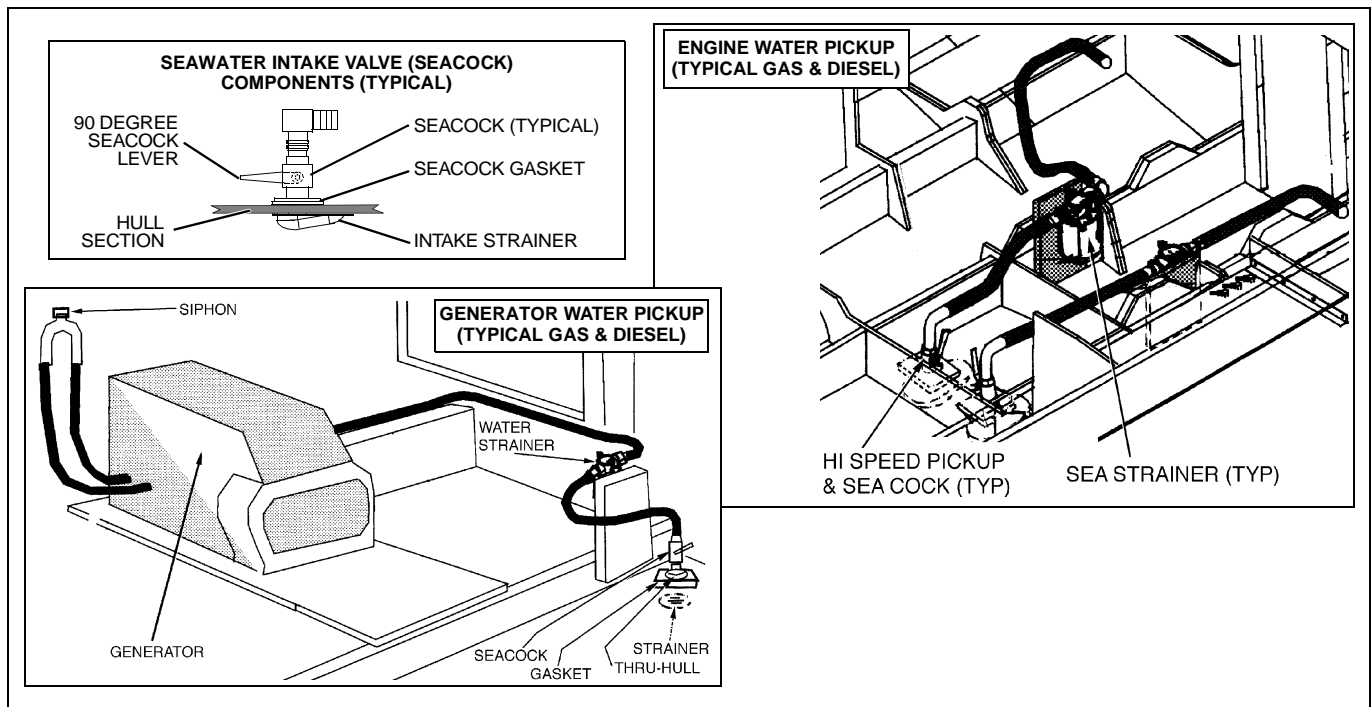

**⚠ CAUTION!**

**SYSTEM DAMAGE HAZARD!**

- Before using a seawater intake system, make sure that the system's seacock is in the *open* position before the system is started and keep the seacock open until the system is shut off.
- Close seacocks whenever the systems will not be used for long periods of time.

### Seacocks

A seacock is a valve, controlled by a 90° lever, used to manage the intake of seawater through the hull and below the water line. Seacocks are typically used on your yacht in the following seawater intake systems:

- Engines
- Generator
- Marine head (toilet)
- Air conditioning system (if equipped)

Before using any of these systems, make sure that the system's seacock is *open* and remains *open* until the system is shut off.

### Seawater Strainers

- Seawater strainers are used in water pickup systems to filter incoming seawater.
- A seawater strainer is located near each system's seacock.
- Check the strainers for leaks and/or debris *every time you use your boat*.
- If debris is found, clean the seawater strainer as follows:
  1. Make sure the component/system (engine, air conditioning system, etc.) that the strainer is connected to is turned OFF.
  2. Close the seacock that sends seawater to the strainer you are about to clean. The seacock must remain closed until the strainer is completely reassembled.
  3. Take apart the seawater strainer.
  4. Remove debris.
  5. Flush strainer with water.
  6. Reassemble the seawater strainer.
  7. Open the seacock and check for leaks around the strainer. If no leaks are found, you may use the component or system.



### CAUTION!

- **FLOODING HAZARD!** The intake seacock that sends seawater to the strainer must be *closed* before disassembling the seawater strainer to prevent the yacht from taking on water through the seawater strainer assembly. Keep the intake seacock *closed* until the seawater strainer is completely reassembled.
- **SYSTEM DAMAGE HAZARD!** After reassembling the seawater strainer, make sure that the intake seacock is open *before* using the component/system.

### Wash Down System (If Equipped)

- The outlet (faucet) for the raw water (seawater) wash down system is located in the aft cockpit engine accessory room.
- The seacock and pump for the wash down system can be accessed through the aft cockpit hatch under the engine room stairs.
- Open the seacock *before* turning the wash down system on.

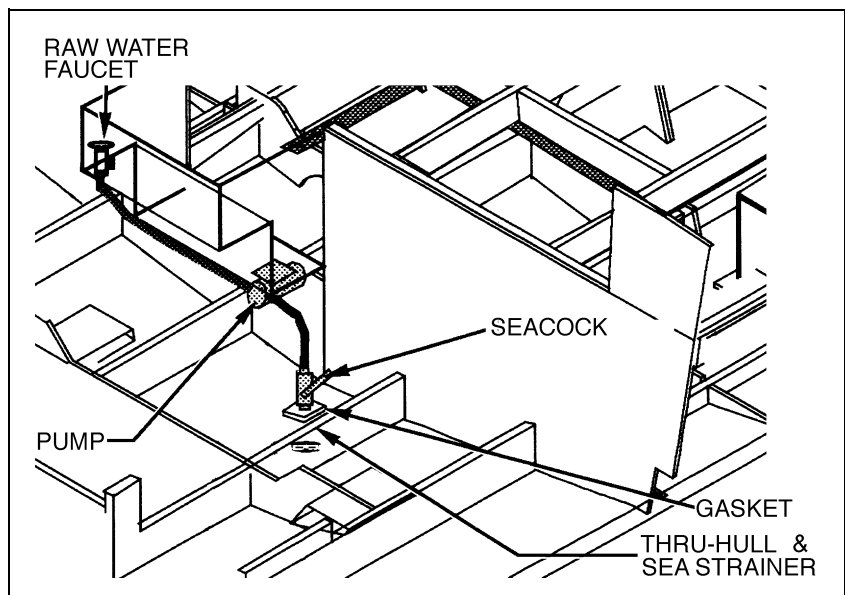

## Marine Head System with Holding Tank

Each head (toilet) comes with its own instruction manual that is included in your owner’s packet. Read the marine head manual thoroughly before using your standard electric or **optional** vacuum head system and refer to it for winterizing recommendations.

- The marine head system installed on your yacht is designed so that waste from each head is flushed into the holding tank.

 **CAUTION!**

**SYSTEM DAMAGE HAZARD!** Before operating the standard electric head system, make sure the system’s seawater pickup seacock is *open*. The seacock must remain open anytime the head system is in use.

- The holding tank can be emptied by dockside pump-out or, where permitted, pumped overboard by turning on the macerator pump from the salon DC panel. The holding tank is located under the hallway floor and can be accessed through hatch inboard of head door.
- The holding tank features a holding tank alert system, located on the DC panel. Empty the tank at every opportunity. The indicator is not precise. To prevent possible illegal spillage of waste, avoid filling the holding tank to capacity.
- Make sure the seacock is open before using the head.
- Check the local regulations regarding the legal use of marine head systems in your area.

**NOTICE**

**Check local regulations regarding the legal use of marine head systems in your area.**

### Standard Head System Routing

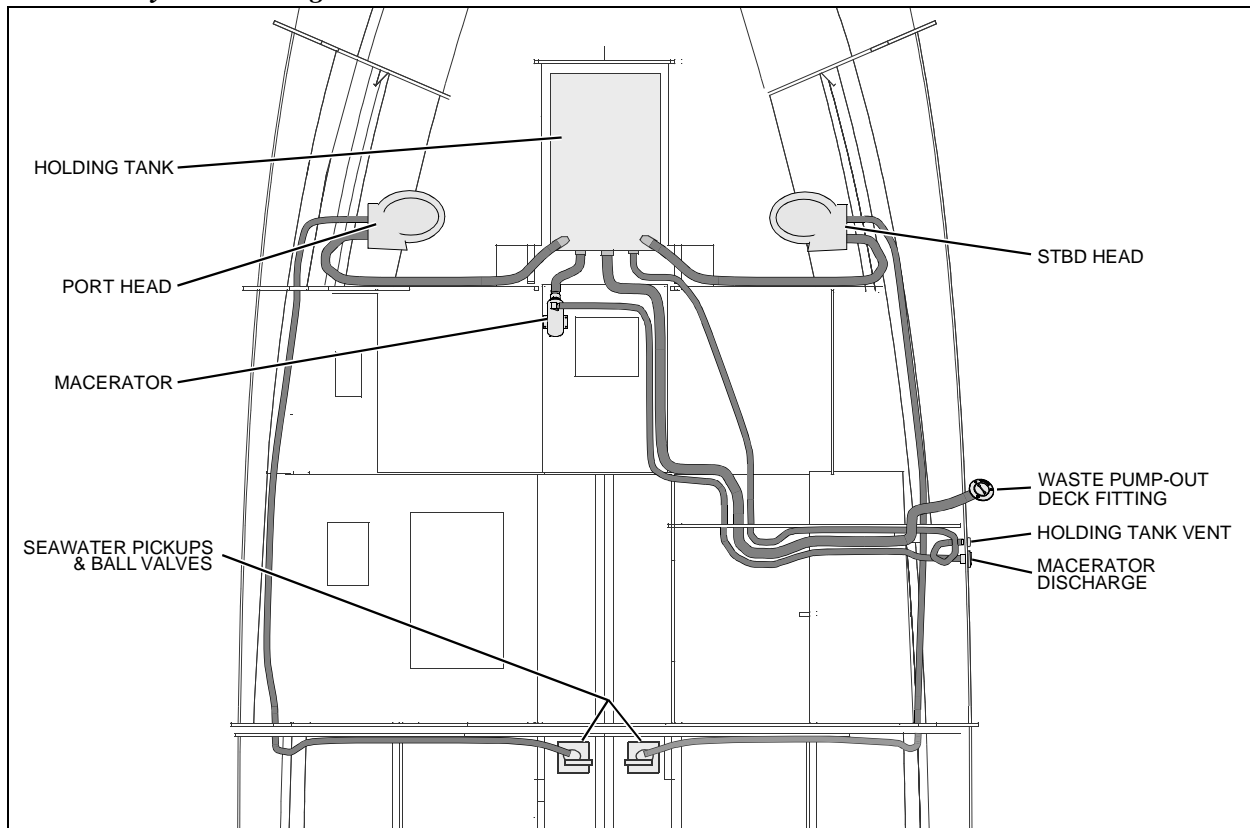

### ***Vacuflush Head System (If Equipped)***

The vacuflush head system uses freshwater and a vacuum generator to flush waste from the toilet into the holding tank. The holding tank is plumbed to a waste fitting on the deck for dockside pump-out.

#### ***Vacuflush System Routing***

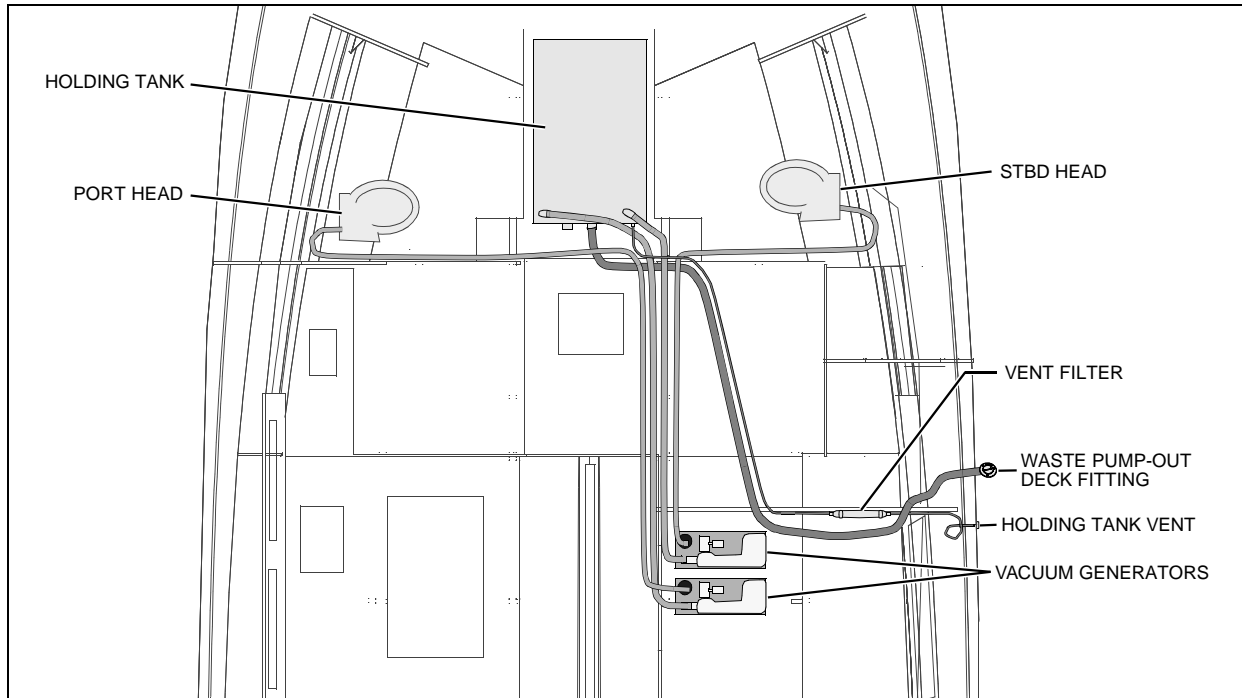

## Bilge Pumps

Your yacht is equipped with six automatic impeller-type bilge pumps which are used to pump water out of the bilge. Bilge pumps are controlled by automatic bilge pump float switches (autofloat switches) and/or switches at the helm. Bilge pumps are wired directly to the battery so they will normally function even when the yacht is completely shut down and left unattended.

**NOTICE**

**Discharge of oil, oil waste or fuel into navigable waters is prohibited by law. Violators are subject to legal action by the local authorities.**

### *Bilge Pump Routing*

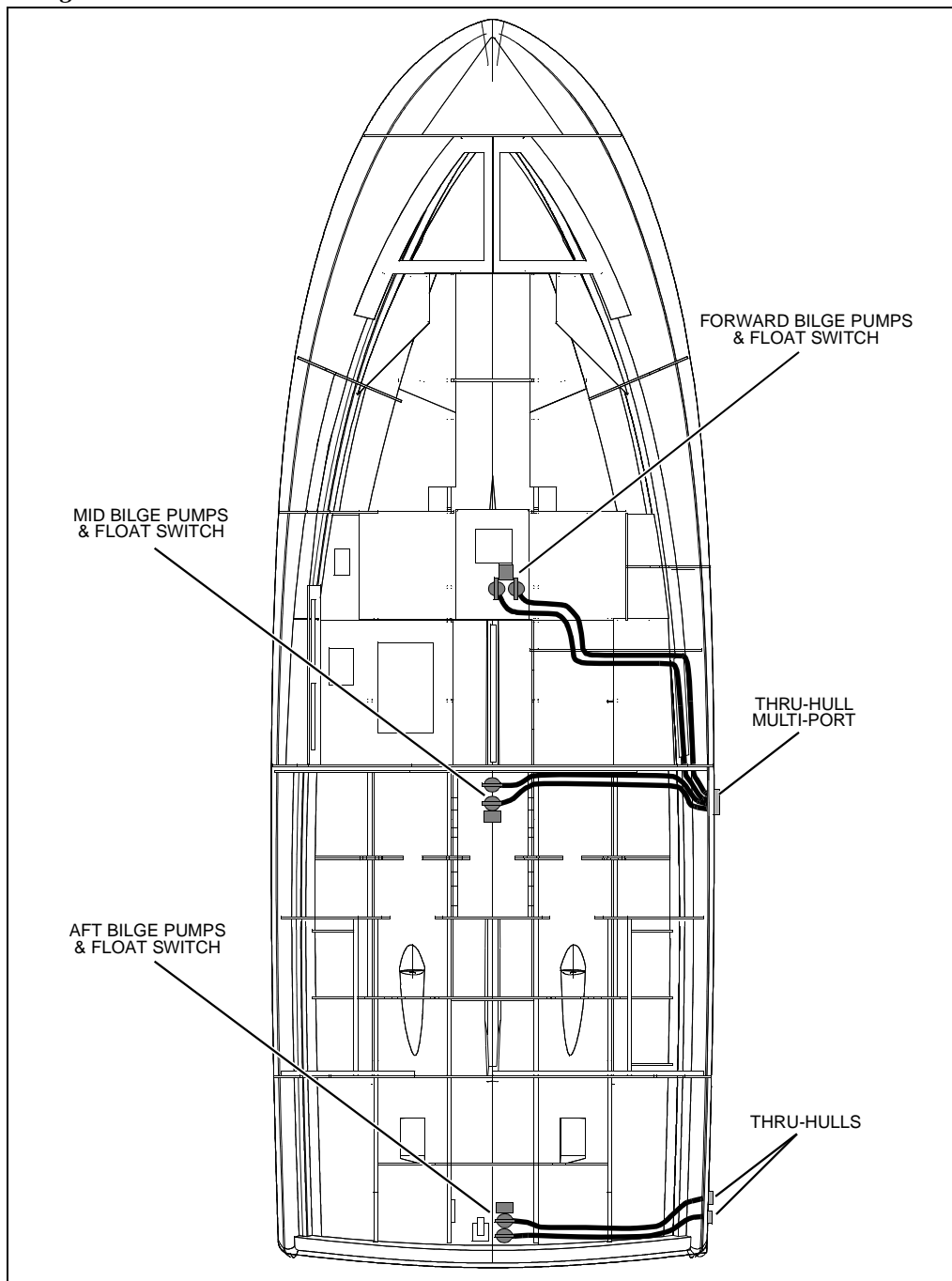

## Bilge Pump Testing

Bilge pumps are critical to the safety of your yacht. Check the bilge pumps often to make sure they are working.

Individually test each pump as follows:

1. Turn on bilge pump switch at helm.
2. Make sure water in bilge is pumped overboard.

If there is water in the bilge and the pump motor is running but not pumping inspect the discharge hose for a kink or collapsed area.

If no problems are found, check the bilge pump housing for clogging debris as follows:

1. Remove power cartridge:
  - a. Lift tab while rotating fins counter-clockwise.
  - b. Lift out power cartridge.
  - c. Clear outer housing of debris.
2. Reinstall power cartridge:
  - a. Make sure "O" ring is properly seated.
  - b. Coat "O" ring with a light film of vegetable or mineral oil.
  - c. Align two cams on either side of power cartridge with two slots on outer housing and press power cartridge into housing while twisting clockwise.
3. Check reinstallation by trying to twist fins counter-clockwise without lifting tab; cartridge should stay in place.

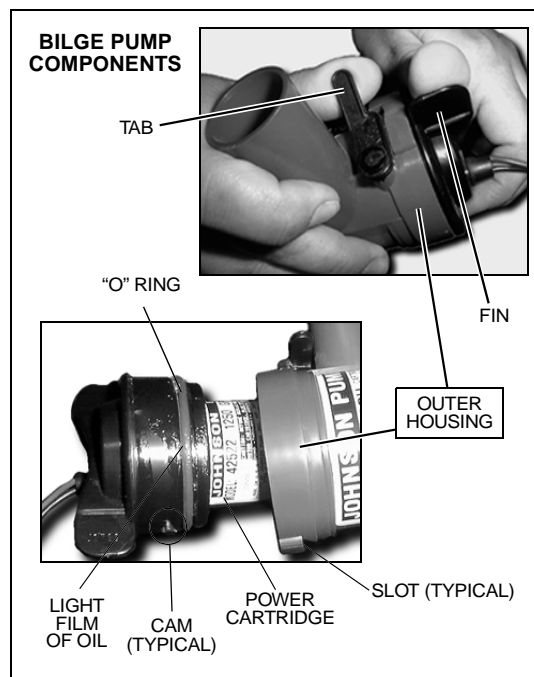

## Autofloat Switches

Automatic bilge pumps use electromagnetic float (autofloat) switches to turn on the pump whenever water rises above a preset level in the bilge. One autofloat switch is mounted next to each automatic bilge pump. Autofloat switches are wired directly to the battery and will normally function even when the yacht is completely shut down and left unattended.

Test the autofloat switches often as follows:

1. Push float switch test button *up* to turn on bilge pump.

If the pump does not turn on, check the inline fuse. If the fuse is good but the switch doesn't work, it may indicate a bad switch or possibly a low battery.

2. Push test button all the way *down* to return the float switch to auto mode.

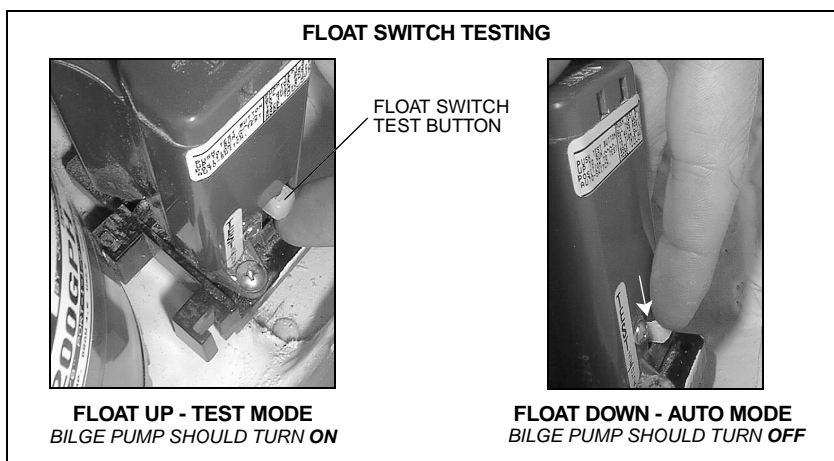

## CAUTION!

When test is completed on each float switch, you **MUST** push the test button *all the way down* to the auto position to return the switch to auto mode!



## Air Conditioner & Heater (If Equipped)

⚠ **DANGER!**



***CARBON MONOXIDE POISONING HAZARD!***

**Dangerous carbon monoxide gas (CO) can be brought into the yacht through the air conditioning system.**

Your yacht may be equipped with an air conditioning and heating system.

- Both heating and cooling are controlled from the same panel.
- Before using the air conditioning and heating system, make sure the breakers on the AC panel are turned on.
- Make sure the seacock is open before using the air conditioning/heating system. The seacock must remain open anytime the air conditioner/heater is in use.
- For further instructions, read the air conditioner and heater manual included in your yacht's owner's packet.

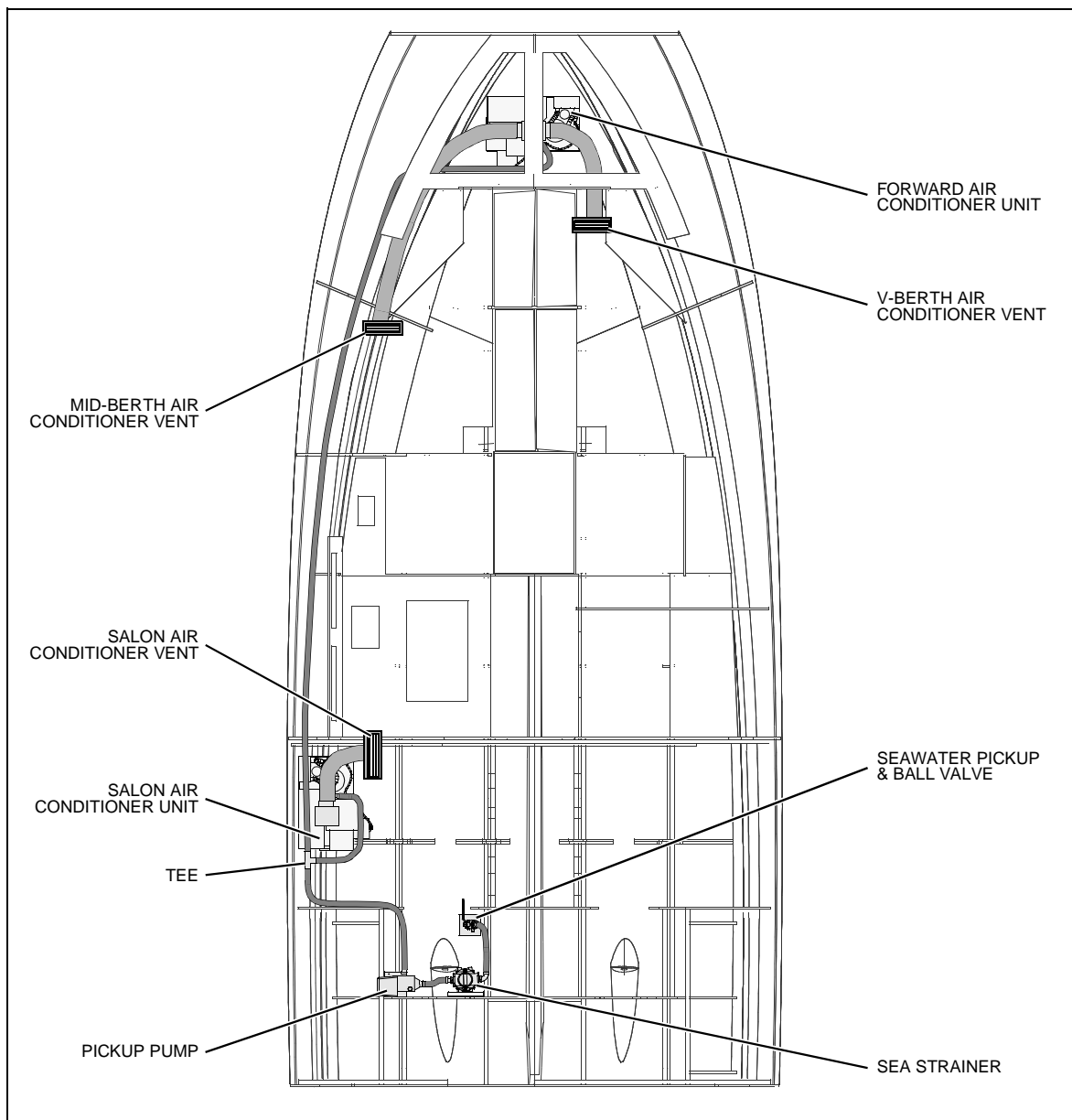

## Electric Heaters (If Equipped)

Your yacht may be equipped with electric cabin heaters. Instructions for this system can be found in the manufacturer's instruction manual included in your yacht's owner's packet.

- Before using the electric heaters, make sure the breakers on the AC panel are turned on.

## Heat Exchanger Cabin Heater (If Equipped)

Your yacht may be equipped with an heat exchanger cabin heater. This heater runs directly off the port engine.

- Before using the heater, make sure the circulation loop shut off valve is open. This valve can be accessed through the inboard wall cutout in the mid-ship state room.
- For further instructions, read the manufacturer's instruction manual included in your yacht's owner's packet.
- The circuit breaker for the heater fan is on the main DC panel in salon and must be on in order for the heater fan's 3-position switch to work.
- If the heater's circulation loop is open and the starboard engine is running, the heater will radiate heat even with the fan turned off.
- All circulation to the heater can be shut off by closing the cutoff valve that can be accessed through the inboard wall cutout in the mid-ship state room.

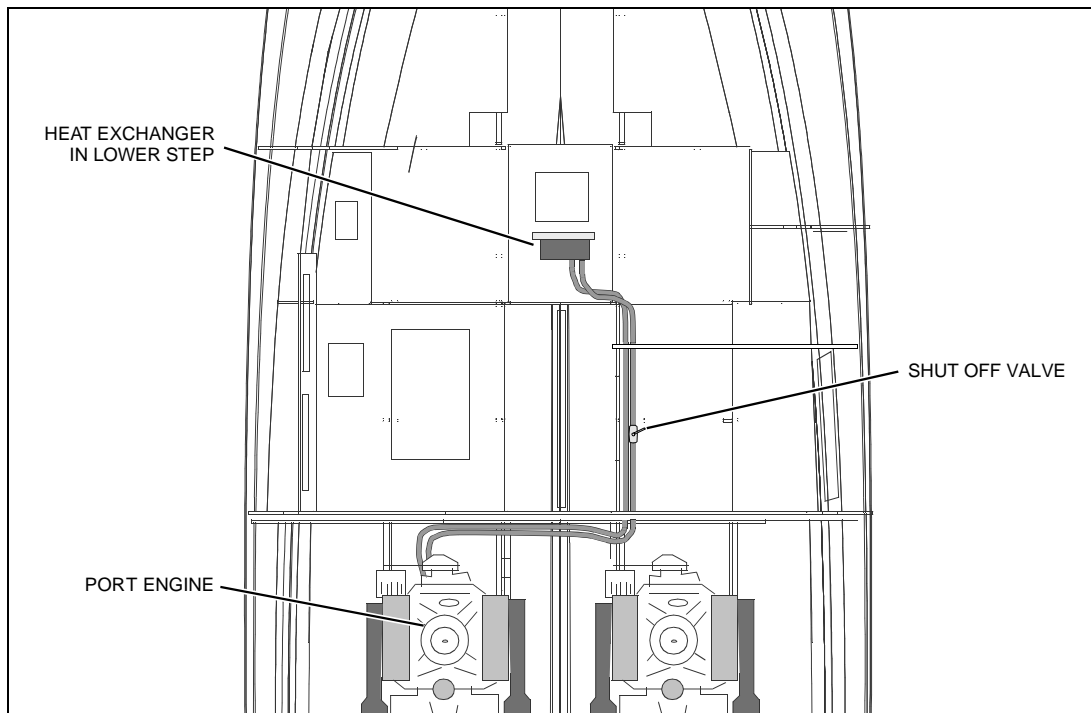

## Appliances

The owner's packet includes instruction manuals for all appliances installed in your yacht. Carefully read and understand these manuals before attempting to use or perform maintenance on any appliance.

Most appliances use 110V AC power, which may be supplied from shore power or generator power. There may not be sufficient generator power to run all AC appliances at the same time. Make sure the AC breaker is turned on for the appliance you wish to use.

### 110-Volt AC/12-Volt DC Refrigerator

Your yacht features 110-volt AC/12-volt DC refrigerators. Please read the manufacturer's instructions supplied in your yacht's owner's packet. The refrigerators runs on 12-volt DC power unless 110-volt AC power is being supplied by the generator or shore power *and* the AC refrigerator breaker is ON.

#### NOTICE

**In less than 24 hours, the refrigerators can render a 100-amp battery useless for engine starting. When operating on 12-volts:**

- **Set the cold setting no higher than two (2).**
- **Turn off your refrigerators at night or when not in use.**
- **If you are going out for more than one day and cannot connect to dockside power, plan to run the engines or generator each day to maintain a charged battery.**

### Range/Oven

Your yacht is equipped with an electric range/oven. Before attempting to use the range/oven, make sure the breaker switch on the AC master panel is ON. Instructions are included in your yacht's owner's packet.



#### WARNING!



#### **BURN HAZARD!**

- **Do not touch stove burners, grates or areas near the stove units as they may be hot even when they are dark in color. Areas near burners and grates may become hot enough to cause burns.**
- **During and after use, do not touch or let clothing or other flammable material come in contact with heated units or areas near the units (burner tops, main frame sides and back, sea rails and pot holders) until they have had sufficient time to cool.**

### Microwave Oven

Before attempting to use the microwave oven, make sure the breaker switch on the AC master panel is ON. Instructions for the microwave oven can be found in your yacht's owner's packet.

## Audio & Visual Equipment

Instruction manuals for all audio and visual equipment is included in your owner's packet.

#### NOTICE

**AM radio reception may be impaired anytime the engines are running.**

# CHAPTER 3: WIRING DIAGRAMS

## Standard Dual Dockside

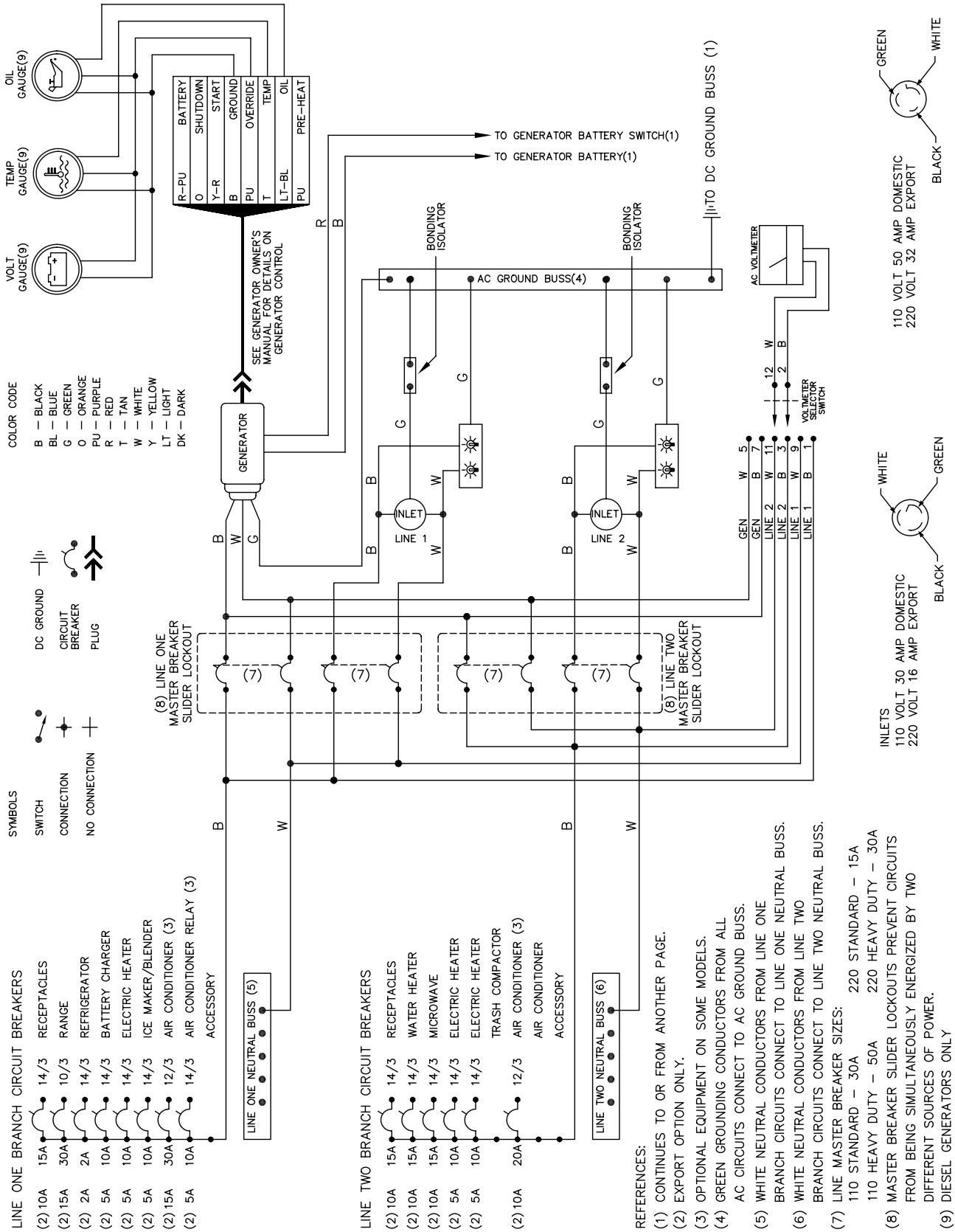

### Accessory DC Circuits

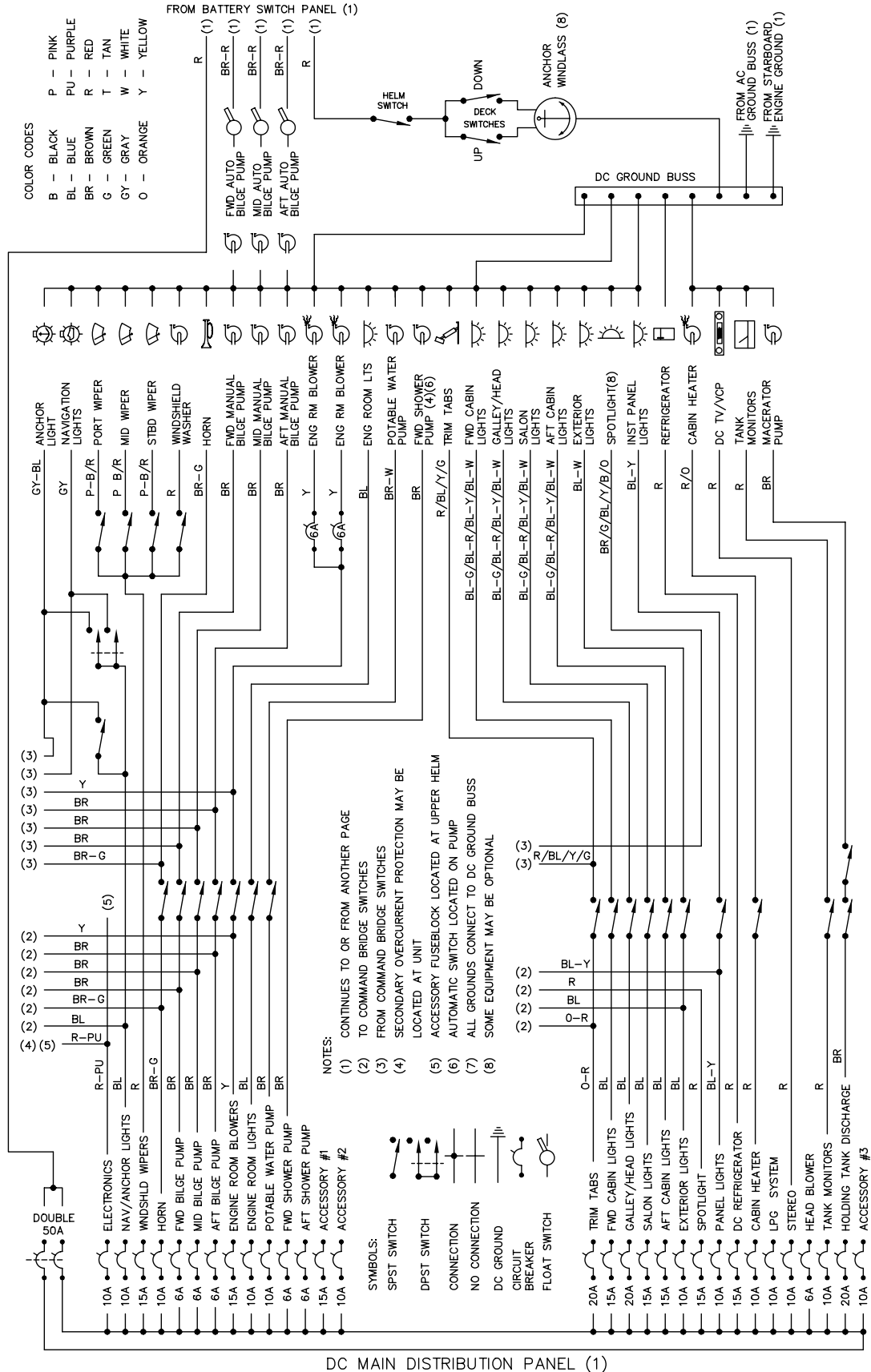

# Gas Engine Electrical System

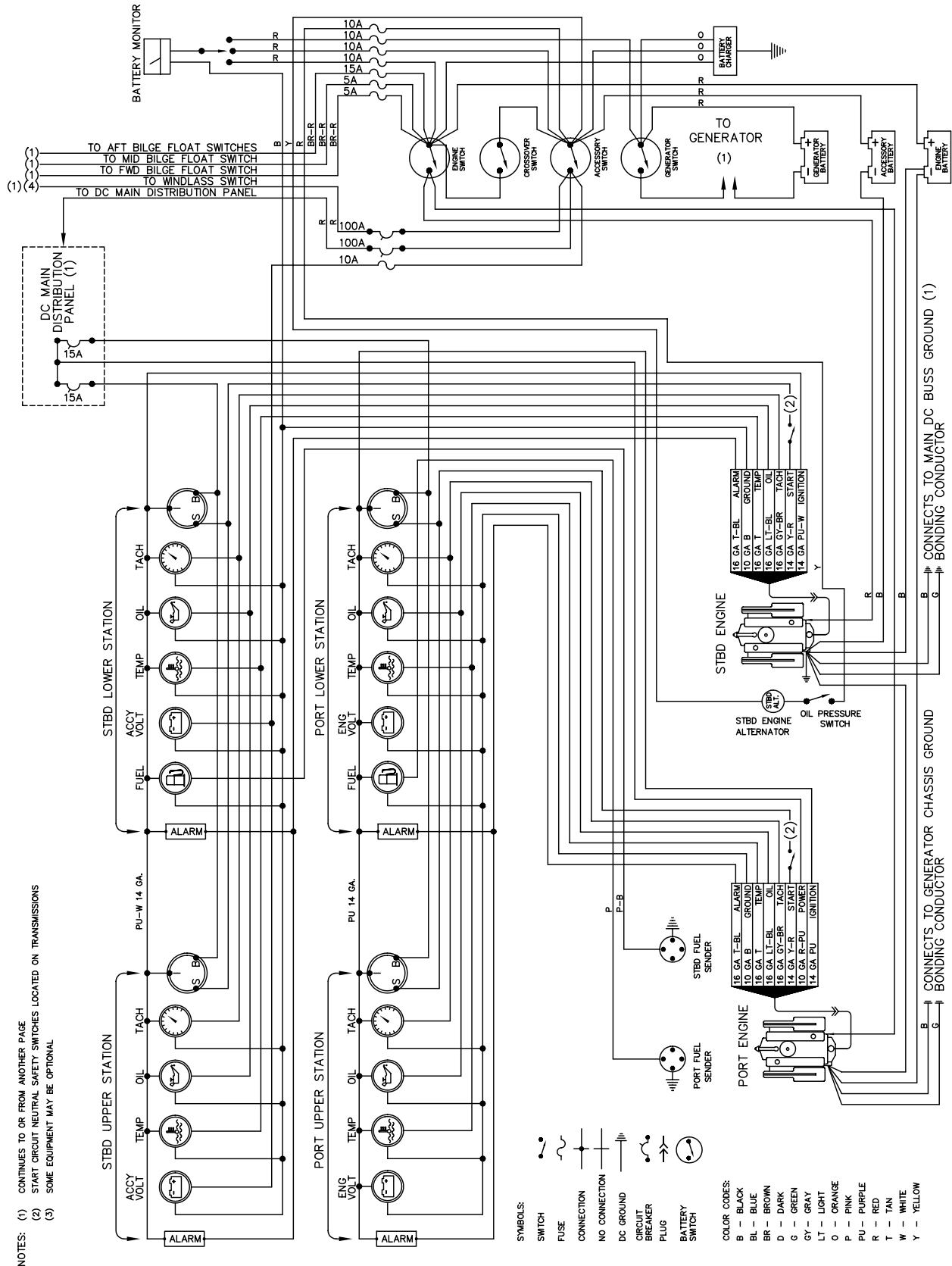

# Diesel Engine Electrical System

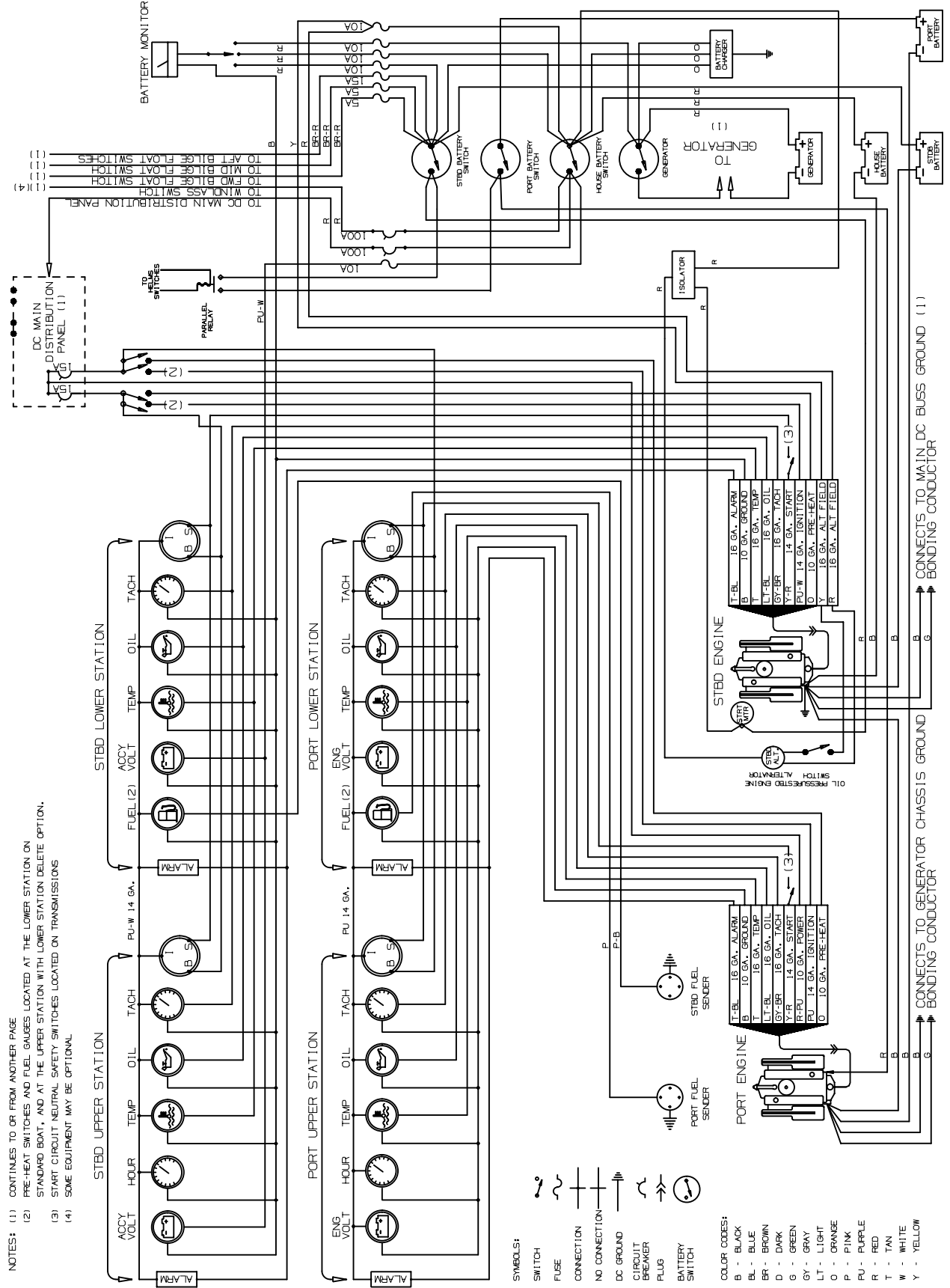











**Part Number 160260**

**Bayliner • P.O. Box 9029 • Everett, WA 98206 • 360-435-5571**