

BAYLINER®

265

Owner's Manual *Supplement*

Engine Serial Number: _____

Hull Identification Number: _____

Hull Identification Number

- The Hull Identification Number (HIN) is located on the starboard side of the transom.
- Record the HIN (and the engine serial numbers) in the space provided above.
- Include the HIN with any correspondence or orders.

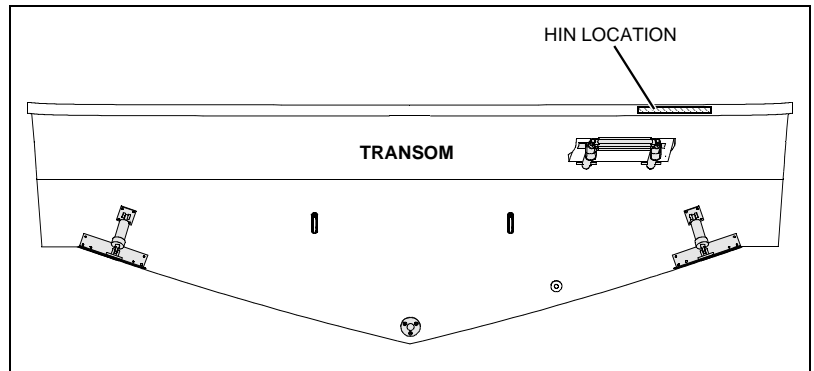

© 2004 Bayliner Technical Publications. All rights reserved.

No part of this publication may be reproduced, stored in any retrieval system, or transmitted in any form by any means, electronic, mechanical, photocopying, recording or otherwise, without prior written permission of Bayliner.
Printed in the United States of America.

General Notes

The material in this document is for information only and is subject to change without notice. While reasonable efforts have been made in the preparation of this document to assure its accuracy, Bayliner assumes no liability resulting from errors or omissions in this document, or from the use of information contained herein. Due to our commitment to product improvement, Bayliner reserves the right to make changes in the product design, specifications, and equipment at any time without notice or obligation. Illustrations and/or photos may show optional equipment.

All Bayliner products meet or exceed USCG (United States Coast Guard) and/or NMMA (National Marine Manufacturer's Association) construction standards. Manufactured with 1,1,1 Trichloroethane, a substance which harms public health and environment during the manufacturing process by destroying ozone in the upper atmosphere.

Proprietary Rights

This document discloses subject matter in which Bayliner has proprietary rights. The information and design disclosed herein were originated by and are the property of Bayliner. Neither receipt nor possession thereof confers or transfers any right to reproduce, copy, alter or disclose the document or any part thereof, any information contained therein, or to construct boats or any item from it, except by written permission from or written agreement with Bayliner. This document is to be returned upon request to Bayliner.

CONTENTS

1 Chapter 1: Welcome Aboard!

- 1 Dimensions and Tank Capacities
- 1 Layout Views
- 2 Dealer Service
- 2 Warranty Information
- 2 Boating Experience
- 2 Engine & Accessories Guidelines
 - 3 Propeller
- 3 Engine & Accessories Literature
- 3 Qualified Maintenance
- 4 Safety Standards
- 5 Special Care For Moored Boats
 - 5 Sacrificial Anodes (Zincs)
- 6 Boat Lifting
- 7 Carbon Monoxide (CO)
 - 7 Facts about CO
 - 8 Where and How CO Can Accumulate
 - 8 How to Protect Yourself and Others From CO
 - 9 CO Checklists
 - 9 Carbon Monoxide Alarm System
 - 10 More Information

11 Chapter 2: Locations

- 11 Exterior Views
 - 11 Hull Views
 - 12 Deck Views
 - 13 Helm
- 14 Component Locations

26 Chapter 3: Propulsion & Related Systems

- 26 Engine
- 26 Bilge Blower System
- 27 Fuel System
 - 28 Fuel Fill & Vent
 - 28 Anti-siphon Valve (Gas Engine Only)
 - 29 Gas Engine Fuel Filters
 - 29 Fuel Filter/Water Separator (Diesel Engine Only)
- 30 Quick Oil Drain System (Gas Engine Only)
- 31 Fire Suppression System (If Equipped)

32 Chapter 4: Controls & Gauges

- 32 Steering
- 32 Shift/Throttle Control
- 32 Power Trim and Tilt
- 33 Trim Tabs
- 34 Gauges
 - 34 Cleaning Gauges
 - 34 Gauge Fogging
 - 34 Radio Transmission Interference
 - 34 Fuel Gauge

35 Chapter 5: Navigation & Communication Equipment

- 35 Compass
- 35 Depth Finder
- 35 VHF Radio (If Equipped)

36 Chapter 6: Plumbing

- 36 Bilge Pumps
 - 37 Bilge Pump Testing
 - 38 Autofloat Switches
- 39 Seawater Systems
 - 39 Seacocks
 - 39 Seawater Strainers
- 40 Freshwater System
 - 41 Freshwater System Winterization
 - 42 Water Heater (If Equipped)
 - 42 Winterizing the Water Heater
 - 43 Transom Shower (If Equipped)
- 43 Drain Systems
 - 43 Deck Drains
 - 43 Gray Water Drains
 - 43 Shower Drain System (If Equipped)
 - 43 Sump Box Cleaning
 - 43 Sump System Winterization
- 44 Marine Head with Holding Tank (If Equipped)
 - 44 Using The Marine Head
 - 44 Winterizing The Marine Head
 - 44 Macerator (If Equipped)
- 44 Portable Toilet (If Equipped)

45 Chapter 7: Deck Equipment

- 45 Cleats and Tow Eyes
- 45 Windlass (If Equipped)
- 46 Ski-Tow Tower (If Equipped)
 - 46 *Attaching the Ski-Tow Rope*
 - 47 *Folding the Ski-Tow Tower*
 - 47 *Tower Care*
- 48 Canvas
 - 49 *Canvas Care*
 - 50 *Clear Vinyl Care*

51 Chapter 8: Appliances & Entertainment Systems

- 51 Audio Equipment
- 51 Refrigerator (If Equipped)
- 52 Alcohol Stove (If Equipped)
- 53 Alcohol/Electric Stove (If Equipped)

54 Chapter 9: Convertible Seats, Beds, & Tables

- 54 Dinette to V-berth Sleeping Area

55 Chapter 10: Lights

- 55 Care and Maintenance
- 55 Interior & Exterior Lights
- 55 Navigation Lights
- 55 Spotlight (If Equipped)

56 Chapter 11: Heating & Air Conditioning System

- 56 Air Conditioning System (If Equipped)

57 Chapter 12: Electrical System

- 58 12-Volt DC System
 - 58 *Battery*
 - 58 *Battery Switch (If Equipped With One Battery)*
 - 59 *Battery Switch (If Equipped With Two Batteries)*
 - 59 *Battery Switch Positions*
 - 60 *Fuses and Circuit Breakers*
 - 60 *12-Volt Accessory Outlet*
 - 60 *Alternator*
 - 60 *Battery Charger (If Equipped)*
- 61 110-Volt AC System (If Equipped)
 - 62 *Shore Power (If Equipped)*
 - 63 *Connecting To Shore Power*
 - 63 *Parallel Switch (If Equipped with Dual Shore Power)*
- 64 Electrical Routings
 - 64 *12-Volt DC Deck Electrical Harnesses*
 - 65 *12-Volt DC Hull Electrical Harnesses*
 - 66 *110-Volt AC Hull Electrical Harnesses (If Equipped)*
- 67 Wiring Diagrams
 - 67 *12-Volt DC Electrical System*
 - 68 *Single Shore Power (If Equipped)*
 - 69 *Dual Shore Power (If Equipped)*
 - 70 *Windlass Wiring Diagram (If Equipped)*
 - 70 *Fire Suppression System Wiring Diagram (If Equipped)*

71 Important Records

72 Float Plan

Hazard Boxes & Symbols

The hazard boxes and symbols shown below are used throughout this supplement to call attention to potentially dangerous situations which could lead to either personal injury or product damage. **Read ALL warnings carefully and follow all safety instructions.**

 **DANGER!**
This box alerts you to immediate hazards which **WILL** cause severe personal injury or death if the warning is ignored.

 **WARNING!**
This box alerts you to hazards or unsafe practices which **COULD** result in severe personal injury or death if the warning is ignored.

 **CAUTION**
This box alerts you to hazards or unsafe practices which **COULD** result in minor personal injury or cause product or property damage if the warning is ignored.

NOTICE
This box calls attention to installation, operation or maintenance information, which is important to proper operation but is not hazard related.



Chapter 1: Welcome Aboard!

- This *Owner's Manual Supplement* provides information about your boat that is **not** covered in the *Cruiser & Yacht Owner's Manual*.
- **Before** using your boat, study this *Owner's Manual Supplement*, the *Cruiser & Yacht Owner's Manual*, and **all** engine and accessory literature carefully.
- Keep this *Owner's Manual Supplement* and the *Cruiser & Yacht Owner's Manual* on your boat in a secure, yet readily available place.

Dimensions and Tank Capacities

Overall Length	Length Rigged	Bridge Clearance	Beam	Draft (Hull)	Draft (Maximum)	Fuel Capacity	Freshwater Capacity	Waste Holding Tank Capacity
27' 0"	27' 12"	6' 9"	8' 6"	1' 10"	3' 3"	75 Gallons	20 Gallons	20 Gallons

Layout Views

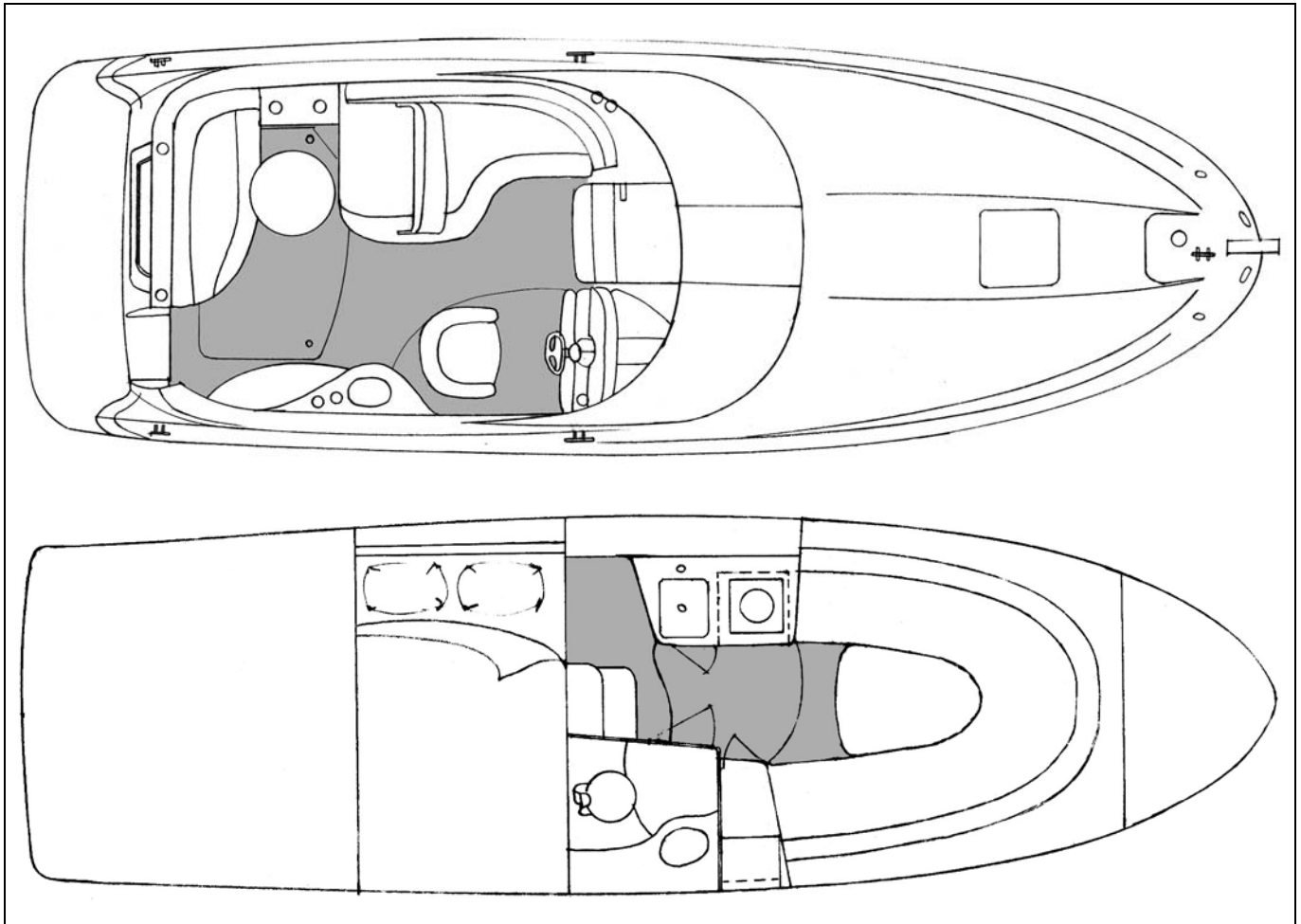

Dealer Service

- Your dealer is your key to service.
- Ask your dealer to explain *all* systems *before* taking delivery of your boat.
- Contact your dealer if you have any problems with your new boat.
- If your dealer cannot help, call our customer service hotline: 360-435-8957 or send us a FAX: 360-403-4235.
- Buy replacement parts from any authorized Bayliner dealer.

Warranty Information

- Bayliner offers a Limited Warranty on each new Bayliner purchased through an authorized Bayliner dealer.
- A copy of the Limited Warranty was included in your owner's packet.
- If you did not receive a copy of the Limited Warranty, please contact your Bayliner dealer or call 360-435-8957 for a copy.

Boating Experience

WARNING!

CONTROL HAZARD!

A qualified operator *must* be in control of the boat at *all* times. Do *NOT* operate your boat while under the influence of alcohol or drugs.

If this is your first boat or if you are changing to a type of boat you are *not* familiar with, for your own comfort and safety, obtain handling and operating experience *before* assuming command of this boat.

Take one of the boating safety classes offered by the U.S. Power Squadrons or the U.S. Coast Guard Auxiliary. For more course information, including dates and locations of upcoming classes, contact the organizations directly:

- U.S. Power Squadrons: 1-888-FOR-USPS (1-888-367-8777) or on the Internet at: <http://www.usps.org>
- In Canada, for the CPS courses call 1-888-CPS-BOAT.
- U.S. Coast Guard Auxiliary: 1-800-368-5647 or on the Internet at: <http://www.cgaux.org>

Outside the United States, your selling dealer, national sailing federation or local boat club can advise you of local sea schools or competent instructors.

Engine & Accessories Guidelines

NOTICE

When storing your boat please refer to your engine's operation and maintenance manuals.

- Your boat's engine and accessories were selected to provide optimum performance and service.
- Installing a different engine or other accessories may cause unwanted handling characteristics.
- Should you choose to install a different engine or to add accessories that will affect the boat's running trim, have an experienced marine technician perform a safety inspection and handling test *before* operating your boat again.

Certain modifications to your boat *will* result in cancellation of your warranty protection.

- *Always* check with your dealer *before* making any modifications to your boat.

Propeller



CAUTION

ENGINE DAMAGE HAZARD!

The factory standard propeller may not be the best for your particular boat and load conditions. Refer to the engine manual for engine RPM ratings. The engine should reach, but not exceed its full rated RPM when full-throttle is applied.

Immediately contact your local Bayliner dealer if:

- The engine cannot reach its full rated RPM when full-throttle is applied, or;
- The engine exceeds its full rated RPM when full-throttle is applied.

- Keep the propeller in good repair and at the correct pitch for your particular situation.
- A slightly bent or nicked propeller will adversely affect the performance of your boat.

Engine & Accessories Literature

- The engine and accessories installed on your boat come with their own operation and maintenance manuals.
- Read these manuals *before* using the engine and accessories.
- Unless noted otherwise, *all* engine and accessory literature referred to in this *Supplement* is included in your owner's packet.

Qualified Maintenance



WARNING!



To maintain the integrity and safety of your boat, allow *only* qualified personnel to perform maintenance on, or in any way modify the:

- Steering System
- Propulsion System
- Engine Control System
- Fuel System
- Environmental Control System
- Electrical System
- Navigational System.

- Failure to maintain your boat's systems (listed in the warning above) as designed could violate the laws in your jurisdiction and could expose you and other people to the danger of bodily injury or accidental death.
- Follow the instructions provided in the *Cruiser & Yacht Owner's Manual*, this *Supplement*, the engine owner's manual and *all* accessory literature.

Safety Standards

⚠ DANGER!	
	<p><i>FALLING and ROTATING PROPELLER HAZARD!</i></p> <ul style="list-style-type: none"> • NEVER allow anyone to ride on parts of the boat <i>not</i> designed for such use. • Sitting on seat backs, lounging on the forward deck, bow riding, gunwale riding or occupying the transom platform while underway is especially hazardous and <i>will</i> cause personal injury or death.

⚠ DANGER!	
 	<p><i>ROTATING PROPELLER and CARBON MONOXIDE POISONING HAZARD!</i></p> <ul style="list-style-type: none"> • NEVER allow anyone to occupy, or hang from, the back deck or swim platform while the engine(s) are running. • Teak surfing, dragging, or water skiing within 20 feet of a moving watercraft can be fatal.

⚠ DANGER!	
<p><i>PERSONAL SAFETY HAZARD!</i></p> <p><i>ALWAYS</i> secure the anchor and other loose objects <i>before</i> getting underway. The anchor and other items that are <i>not</i> properly secured can come loose when the boat is moving and cause personal injury or death.</p>	

- Your boat's mechanical and electrical systems were designed to meet safety standards in effect at the time it was built.
- Some of these standards were mandated by law, all of them were designed to insure your safety, and the safety of other people, vessels and property.

In addition to this *Supplement*, please read the *Cruiser & Yacht Owner's Manual* and **all** accessory instructions for important safety standards and hazard information.

Special Care For Moored Boats

NOTICE

- To help seal the hull bottom and reduce the possibility of gelcoat blistering on moored boats, apply an epoxy barrier coating.
- The barrier coating should be covered with several coats of anti-fouling paint.
- Many states regulate the chemical content of bottom paints in order to meet environmental standards. Check with your local dealer about recommended bottom paints, and about the laws in effect in your area.

- Whether moored in saltwater or freshwater, your boat will collect marine growth on its hull bottom.
- This will detract from the boat's beauty, greatly affect its performance and may damage the gelcoat.
- Periodically haul the boat out of the water and scrub the hull bottom with a bristle brush and a solution of soap and water.

Sacrificial Anodes (Zincs)

NOTICE

- Do **NOT** paint between the zinc and the metal surface it contacts and do **NOT** paint over the zincs.
- If the zincs are *not* bonded correctly, they will *not* provide protection.

Your boat is equipped with sacrificial anodes (zincs) to protect underwater metal parts from excessive deterioration. Check the zincs regularly and replace them if they have deteriorated more than 70%.

There are many factors that affect the rate at which the zincs deteriorate, including:

- Water temperature.
- Salinity.
- Water pollution.
- Stray electrical current from the boat or dock may cause complete deterioration in just a few weeks.
- If there is rapid zinc deterioration, measure the electrolytic corrosion around your boat with a Corrosion Test Meter.

Boat Lifting



WARNING!

PERSONAL INJURY and /or PRODUCT OR PROPERTY DAMAGE HAZARD!

- Lifting slings may slip on the hull.
- Avoid serious injury or death by securing the lifting slings together *before* lifting.



WARNING!

PERSONAL INJURY and /or PRODUCT OR PROPERTY DAMAGE HAZARD!

- **NEVER** lift any boat using the cleats, or the bow and stern eyes.



WARNING!

PERSONAL INJURY and /or PRODUCT OR PROPERTY DAMAGE HAZARD!

- Water in the bilge can shift and change the balance of the load.
- If water is present in the bilge, pump or drain the water out of the bilge areas *before* lifting your boat.



CAUTION

PRODUCT or PROPERTY DAMAGE HAZARD!

- When lifting any boat, *always* use a spreader bar. The spreader bar *must* be equal to the width of the boat at each lifting point.

- *Always* follow the lift equipment's instructions and requirements.
- When lifting your boat, *always* position the lifting slings at the port and starboard lifting sling label positions as shown in the illustration.

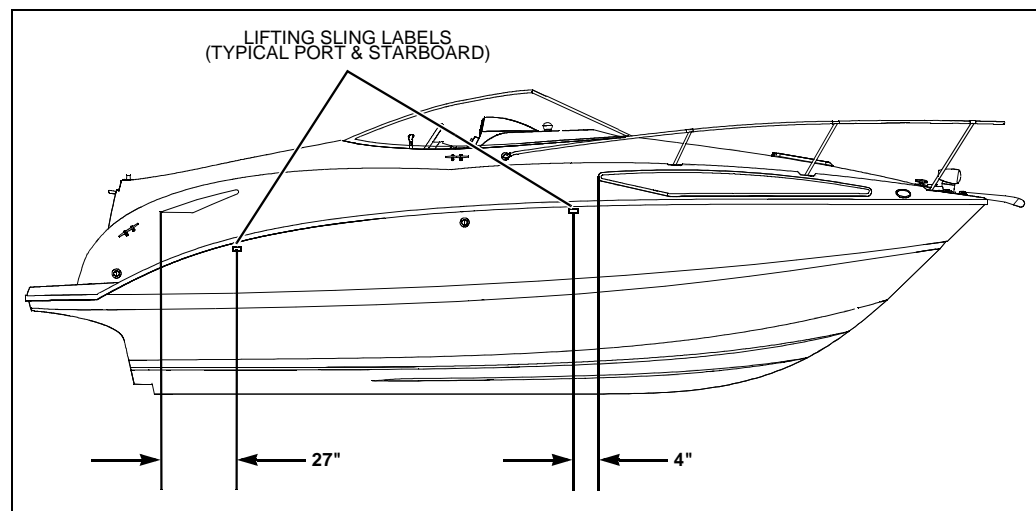

Carbon Monoxide (CO)

⚠ DANGER!	
	<ul style="list-style-type: none"> • Carbon monoxide gas (CO) is colorless, odorless, tasteless, and extremely dangerous. • <i>All</i> engines and fuel burning appliances produce CO as exhaust. • Prolonged exposure to low concentrations or very quick exposure to high concentrations <i>will</i> cause <i>BRAIN DAMAGE</i> or <i>DEATH</i>. • Teak surfing, dragging, or water skiing within 20 feet of a moving watercraft can be fatal.

Facts about CO

- CO poisoning causes a significant number of boating deaths each year.
- Called the "silent killer", CO is an extremely toxic, colorless, odorless and tasteless gas.
- CO can harm or even kill you inside or outside your boat.
- CO can affect you whether you're underway, moored, or anchored.
- CO symptoms are similar to seasickness or alcohol intoxication.
- CO can make you sick in seconds. In high enough concentrations, even a few breaths can be fatal.
- Breathing CO blocks the ability of your blood to carry oxygen.
- The effects are cumulative, even low levels of exposure can result in injury or death.

Factors That Increase the Effects of CO Poisoning

- Age
- Smokers or people exposed to high concentrations of cigarette smoke
- Consumption of alcohol
- Lung disorders
- Heart problems
- Pregnancy

Where and How CO Can Accumulate

Stationary Conditions That Increase CO Accumulations Include:

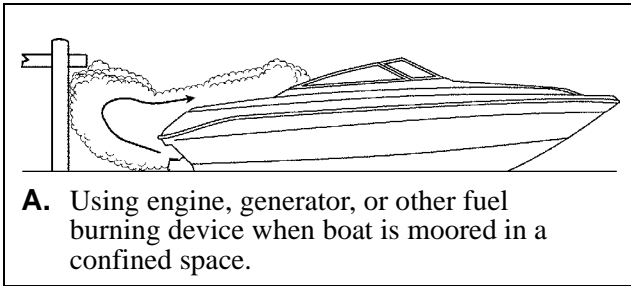

A. Using engine, generator, or other fuel burning device when boat is moored in a confined space.

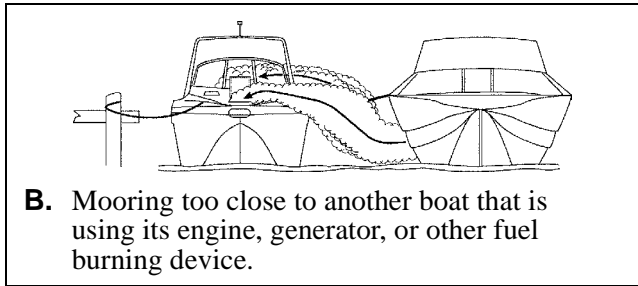

B. Mooring too close to another boat that is using its engine, generator, or other fuel burning device.

To correct stationary situations A and/or B:

- **Close all** windows, portlights and hatches.
- If possible, move your boat away from source of CO.

Running Conditions That Increase CO Accumulations Include:

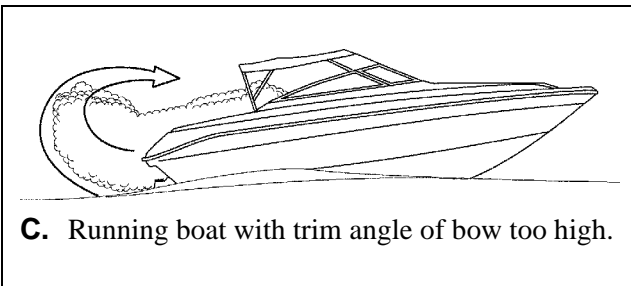

C. Running boat with trim angle of bow too high.

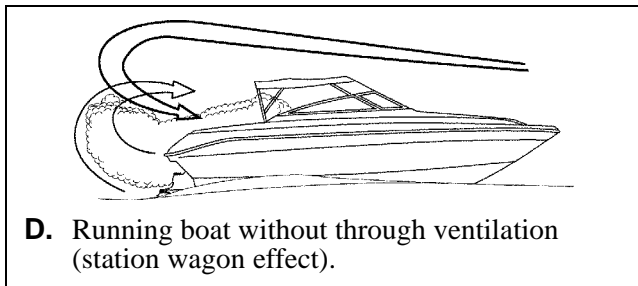

D. Running boat without through ventilation (station wagon effect).

To correct running situations C and/or D:

- Trim bow down.
- **Open** windows and canvas.
- When possible, run boat so that prevailing winds help dissipate exhaust.

How to Protect Yourself and Others From CO

- Know where and how CO may accumulate in and around your boat (see above).
- Maintain fresh air circulation throughout the boat at **all** times.
- Know where your engine and generator exhaust outlets are located and keep everyone away from these areas.
- **Never** sit on, or hang onto, the back deck or swim platform while the engine(s) are running.
- **Never** enter the areas under swim platforms where exhaust outlets are located.
- Although CO can be present without the smell of exhaust fumes, if exhaust fumes are detected on the boat, take **immediate** action to dissipate these fumes.
- Treat symptoms of seasickness as possible CO poisoning. Get the person into fresh air **immediately**. Seek medical attention—unless you're sure it's not CO.
- Install and maintain CO monitors inside your boat. Do **not** ignore any alarm. Replace monitors as recommended by the monitor manufacturer.
- Follow the checklists provided on the next page.
- Get a Vessel Safety Check.

For information on how to get a free VESSEL SAFETY CHECK, visit www.vesselsafetycheck.org or contact your local U.S. Coast Guard Auxiliary or United States Power Squadrons®.

- U.S. Coast Guard Auxiliary: 1-800-368-5647 or on the Internet at: <http://www.cgaux.org>
- U.S. Power Squadrons: 1-888-FOR-USPS (1-888-367-8777) or on the Internet at: <http://www.usps.org>

CO Checklists

Trip Checklist

- Make sure you know where the exhaust outlets are located on your boat.
- Educate *all* passengers about the symptoms of CO poisoning and where CO may accumulate.
- When docked, or rafted with another boat, be aware of exhaust emissions from the other boat.
- Listen for any change in exhaust sound, which could indicate an exhaust component failure.
- Test the operation of each CO alarm by pressing the test button.

Monthly Checklist

- Make sure *all* exhaust clamps are in place and secure.
- Look for exhaust leaking from exhaust system components. Signs include rust and/or black streaking, water leaks, or corroded or cracked fittings.
- Inspect rubber exhaust hoses for burned, cracked, or deteriorated sections. *All* rubber hoses should be pliable and free of kinks.

Annual Checklist

Have a Qualified Marine Technician:

- Replace exhaust hoses if cracking, charring, or deterioration is found.
- Ensure that your engines and generators are properly tuned, and well maintained.
- Inspect each water pump impeller and the water pump housing. Replace if worn. Make sure cooling systems are in working condition.
- Inspect *all* metallic exhaust components for cracking, rusting, leaking, or loosening. Make sure they check the cylinder head gasket, exhaust manifold, water injection elbow, and the threaded adapter nipple between the manifold and the elbow.
- Clean, inspect, and confirm proper operation of the generator cooling water anti-siphon valve (if equipped).

Carbon Monoxide Alarm System

NOTICE

- **The stereo memory and the CO monitor place a small, but constant drain on the battery.**
- **If your boat will be unattended for an extended amount of time, plug into shore power with the battery charger turned *On*.**

- Do *not* disconnect the CO monitor.
- Read the manufacturer's instructions for your CO monitor. **If you did not receive the manufacturer's instructions, call (800) 383-0269 and one will be mailed to you.**

If your boat is *not* equipped with a CO monitor, consider purchasing one from your dealer or marine supply store.

More Information

For more information about how you can prevent carbon monoxide poisoning on recreational boats and other ways to boat more safely, contact:

United States Coast Guard
Office of Boating Safety (G-OPB-3)
2100 Second Street SW
Washington, DC 20593
www.uscgboating.org
1-800-368-5647

National Marine Manufacturers
Association (NMMA)
200 East Randolph Drive
Suite 5100
Chicago, IL 60601-9301
www.nmma.org
312-946-6200

American Boat & Yacht Council, Inc.
(ABYC)
3069 Solomon's Island Road
Edgewater, MD 21037-1416
www.abycinc.org
410-956-1050

For information on how to get a free VESSEL SAFETY CHECK, visit www.vesselsafetycheck.org or contact your local U.S. Coast Guard Auxiliary or United States Power Squadrons®.

- U.S. Coast Guard Auxiliary: 1-800-368-5647 or on the Internet at: <http://www.cgaux.org>
- U.S. Power Squadrons: 1-888-FOR-USPS (1-888-367-8777) or on the Internet at: <http://www.usps.org>

Chapter 2: Locations

Exterior Views

Hull Views

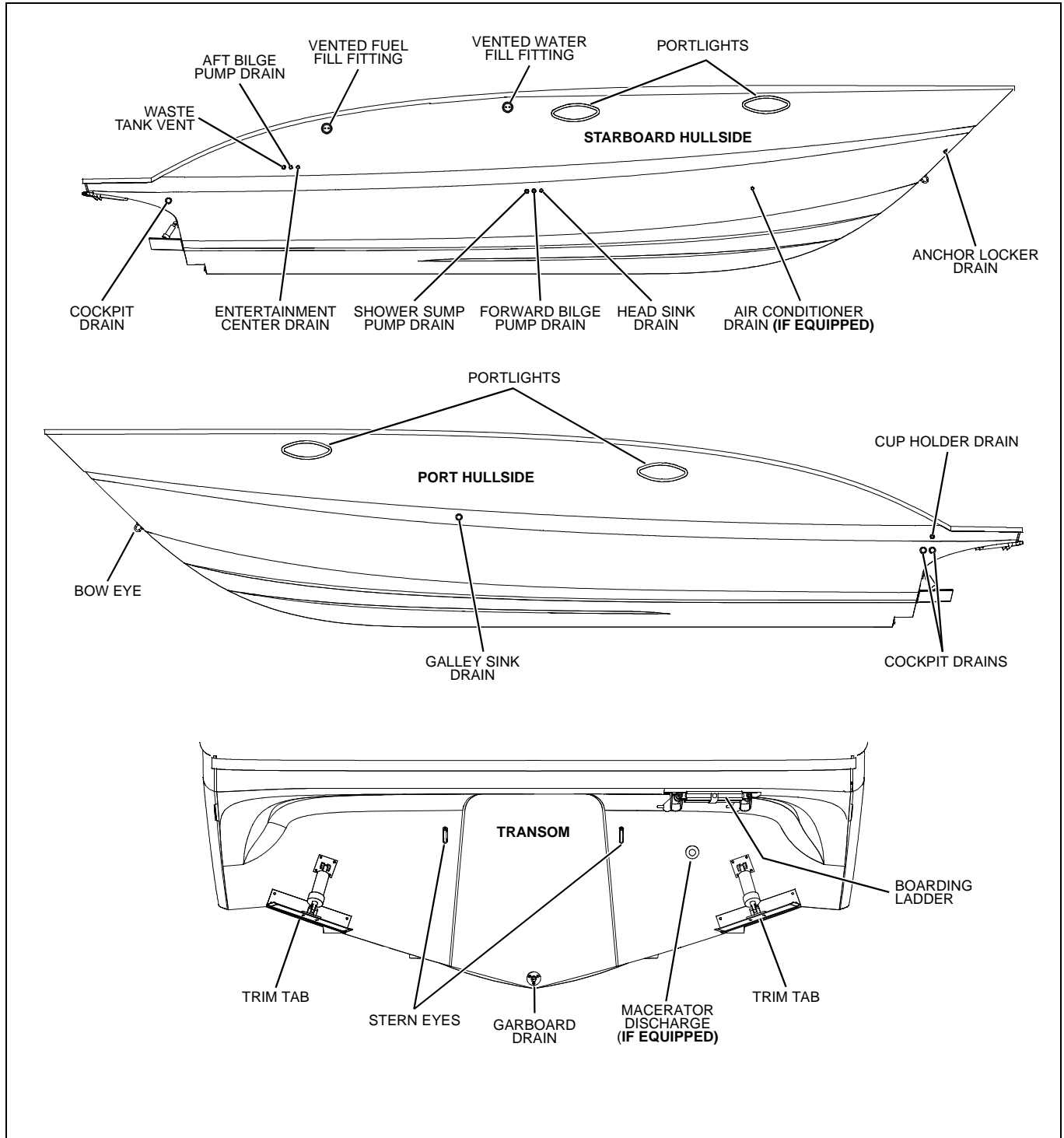

Deck Views

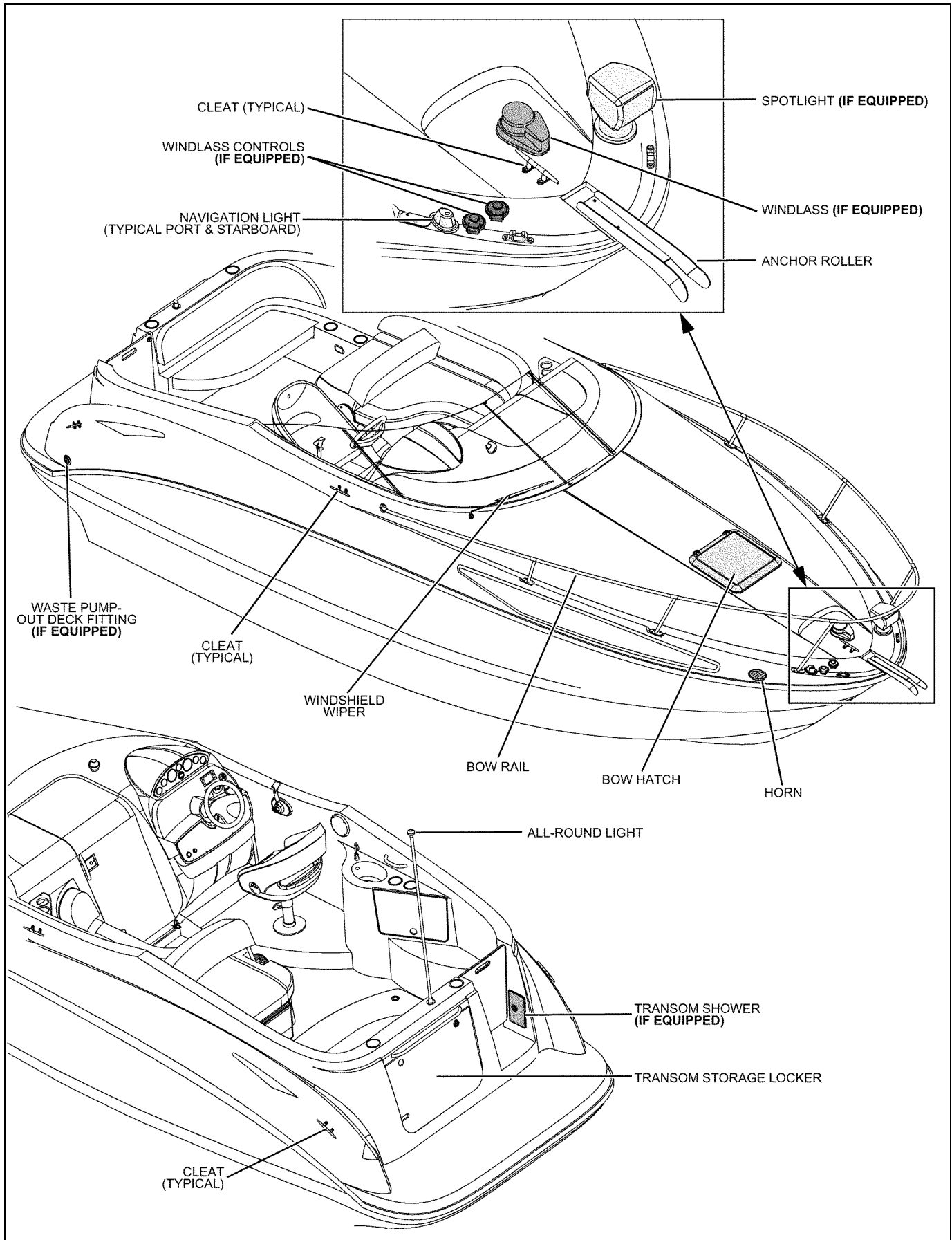

Helm

**NOTE: TYPICAL HELM LAYOUT SHOWN
ACTUAL LAYOUT MAY VARY DEPENDING
ON ENGINE AND ACCESSORY OPTIONS**

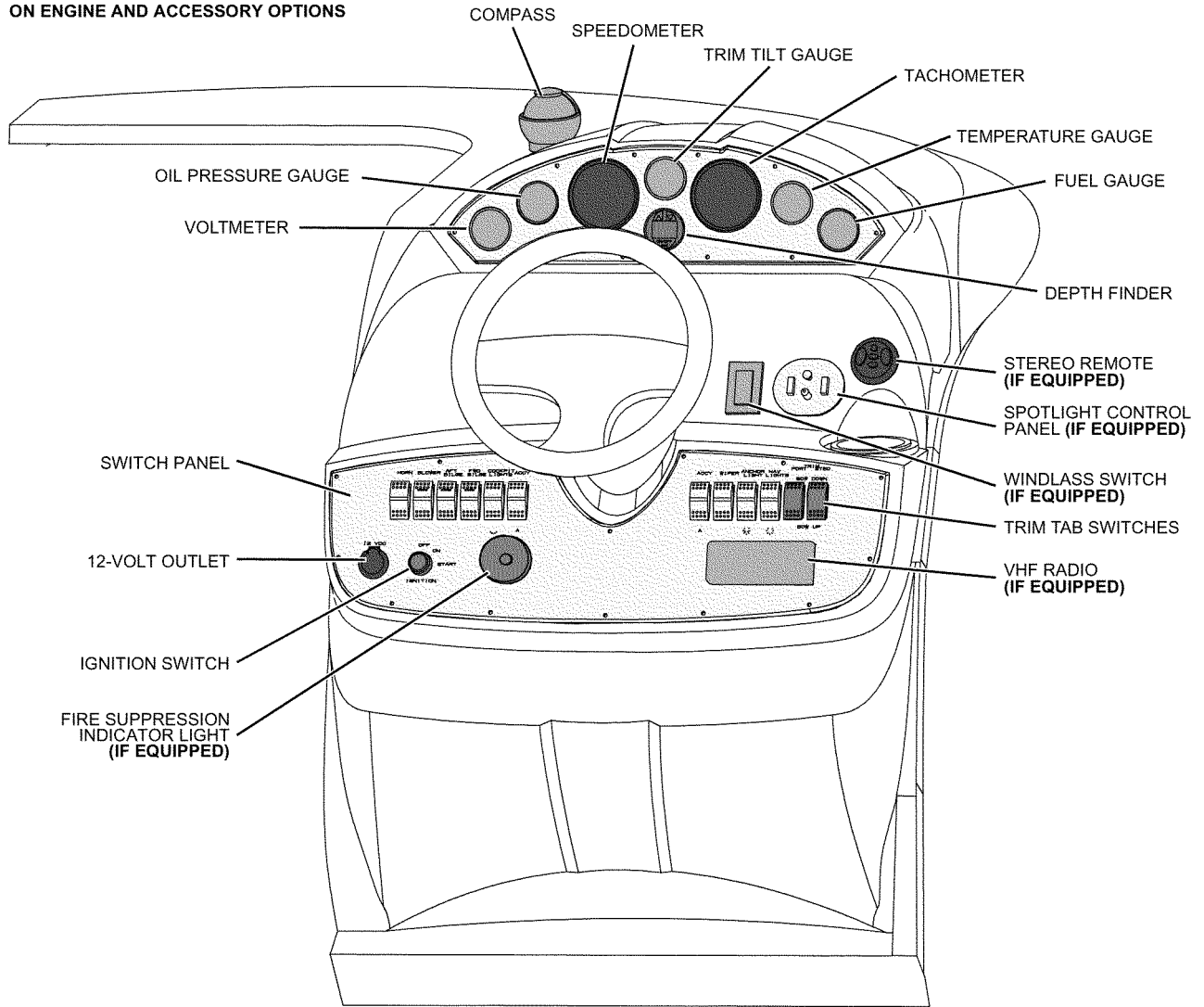

Component Locations

12-Volt Accessory Outlets:

- One located at the helm, on the switch panel.

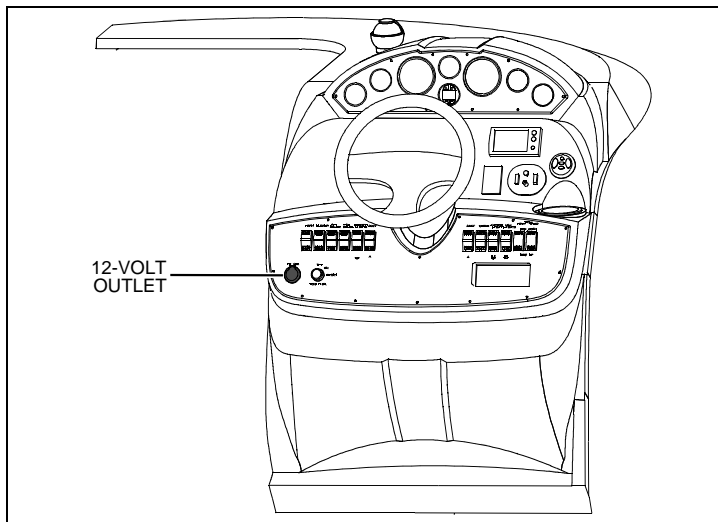

- One located on the aft end of the lower galley cabinet.
- One located on the aft end of the upper galley cabinet, next to the audio jacks (If Equipped).

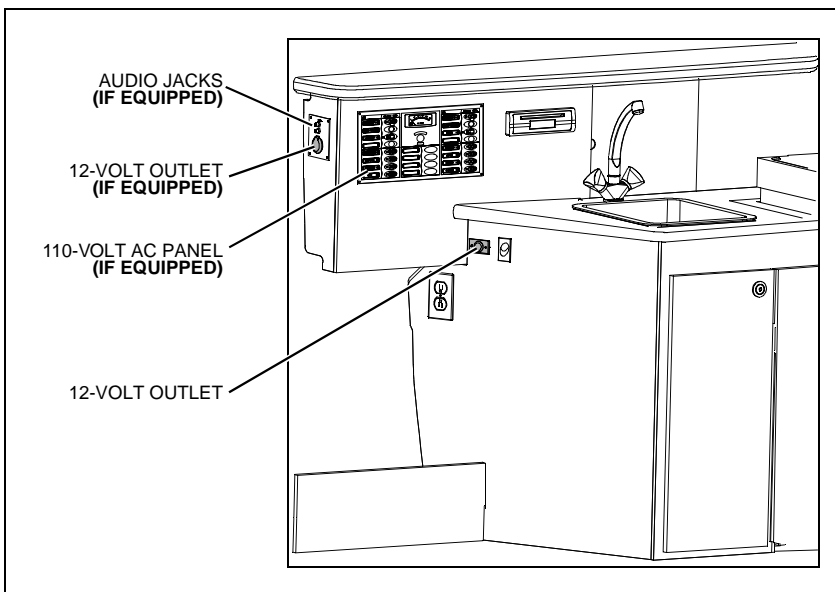

110-Volt AC Panel (If Equipped):

- Located in the galley.

Air Conditioner Seawater Intake Seacock (If Equipped):

- Located on the starboard aft side of the engine room.

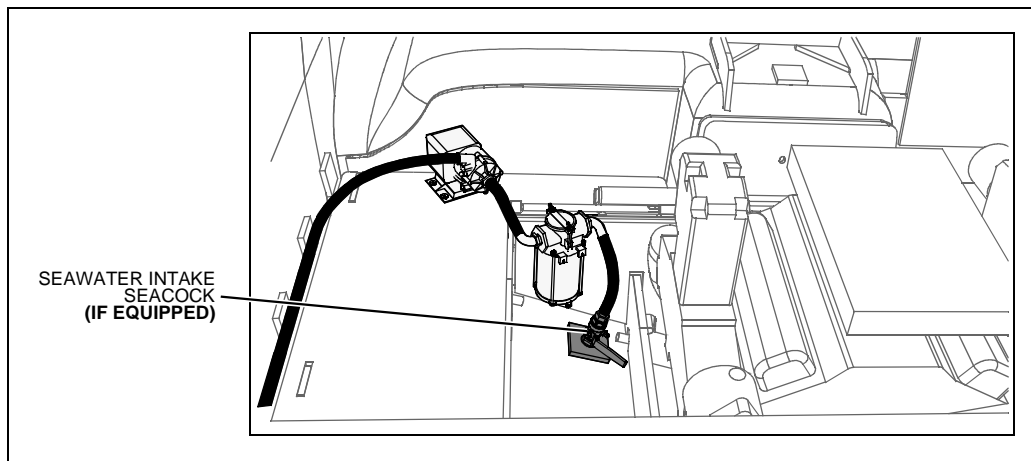

Air Conditioner Unit (If Equipped):

- Located in the storage locker under the starboard aft seat cushion in the v-berth.

Air Conditioner Control Panel (If Equipped):

- Located on the forward side of the starboard cabinet in the v-berth.

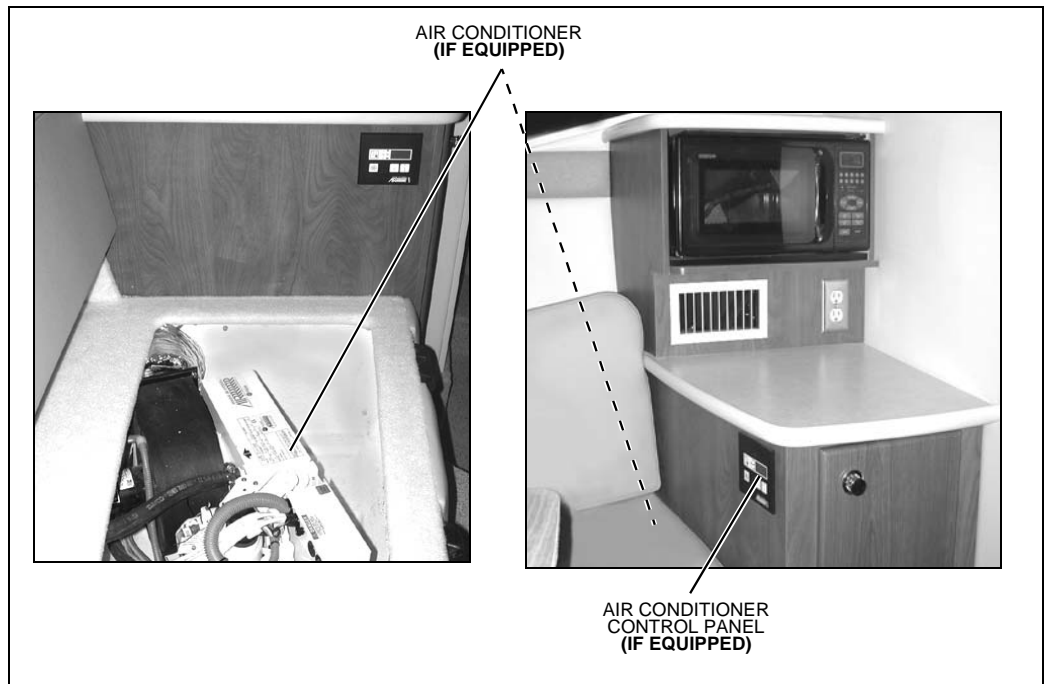

Batteries:

- Located on the port side of the engine room.
- Note: Actual number of batteries may vary depending on options.

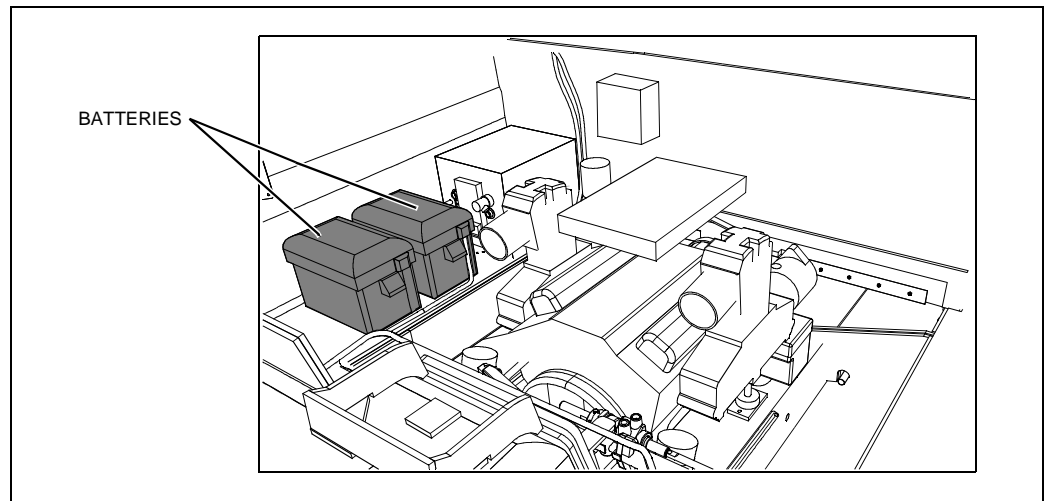

Battery Charger (If Equipped):

- Located on the port side of the engine room, on the forward wall.

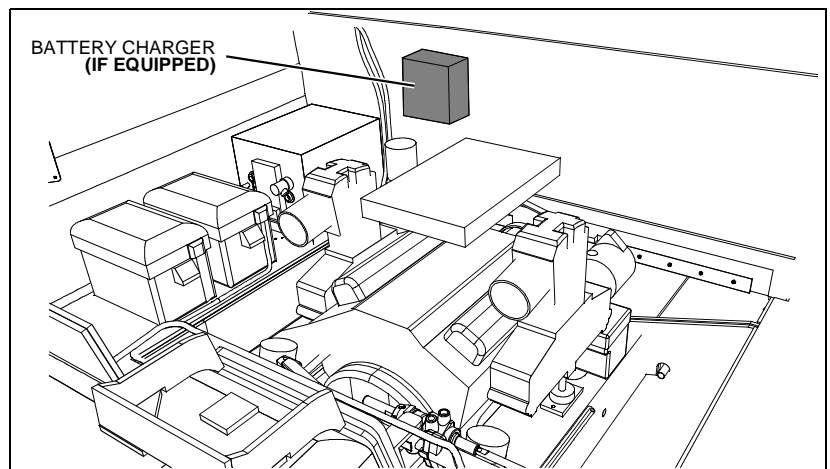

Battery Switch(es):

- Located inside the transom storage locker.

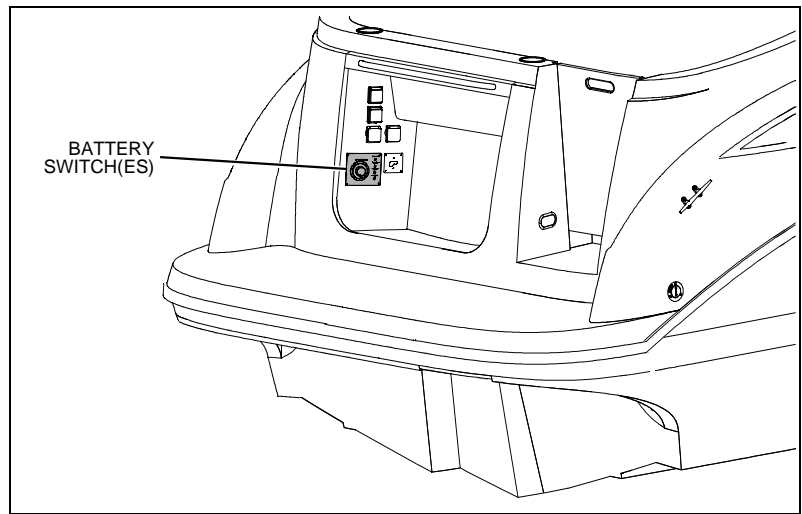
**Bilge Pump and Float Switch - Aft:**

- Located in the engine room, forward of the engine.

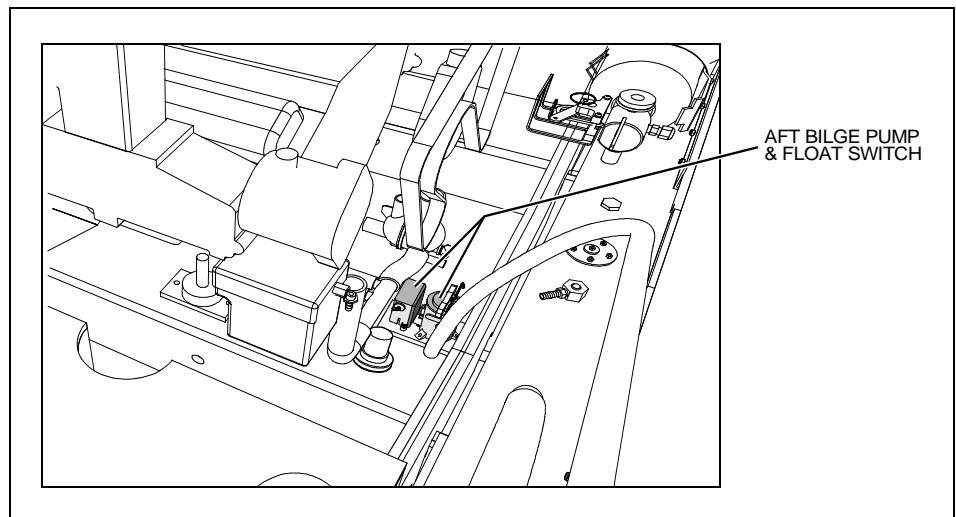
**Bilge Pump and Float Switch - Forward:**

- Located in the bilge under the bottom entry step.
- Access by lifting up the bottom entry step.

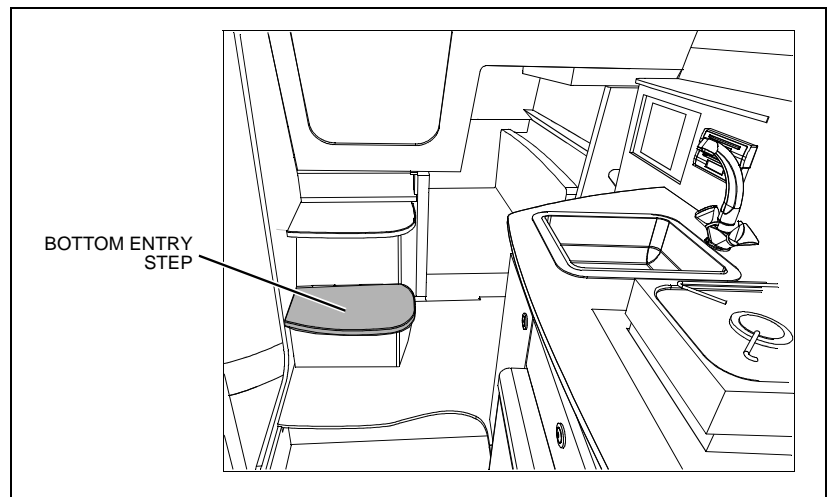

Carbon Monoxide Monitor:

- Located on the valance on the starboard aft corner of the v-berth ceiling

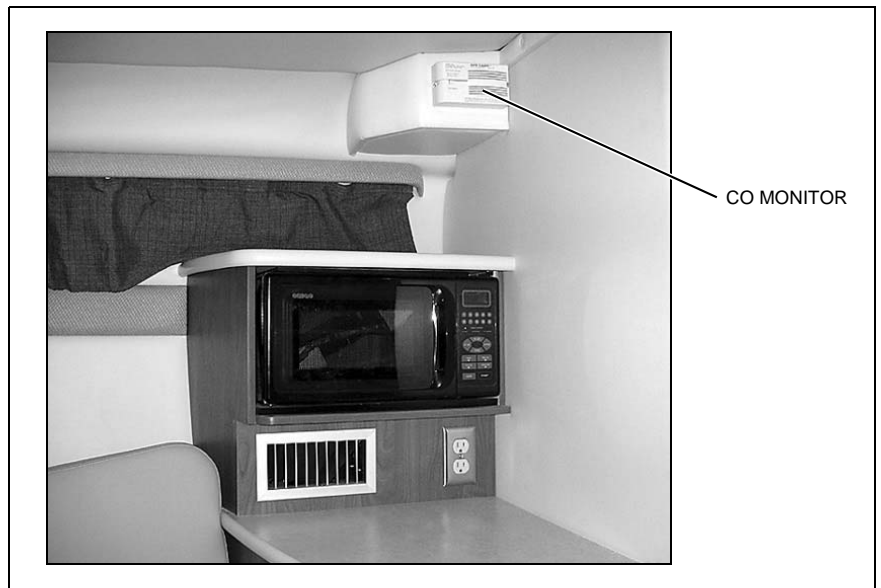

Circuit Breakers:

The following circuit breakers are all located inside the transom storage locker:

- Shore power master circuit breaker(s) (if equipped with shore power);
- Windlass circuit breaker (if equipped with a windlass);
- DC main circuit breaker, and;
- DC stand-by loads circuit breakers.

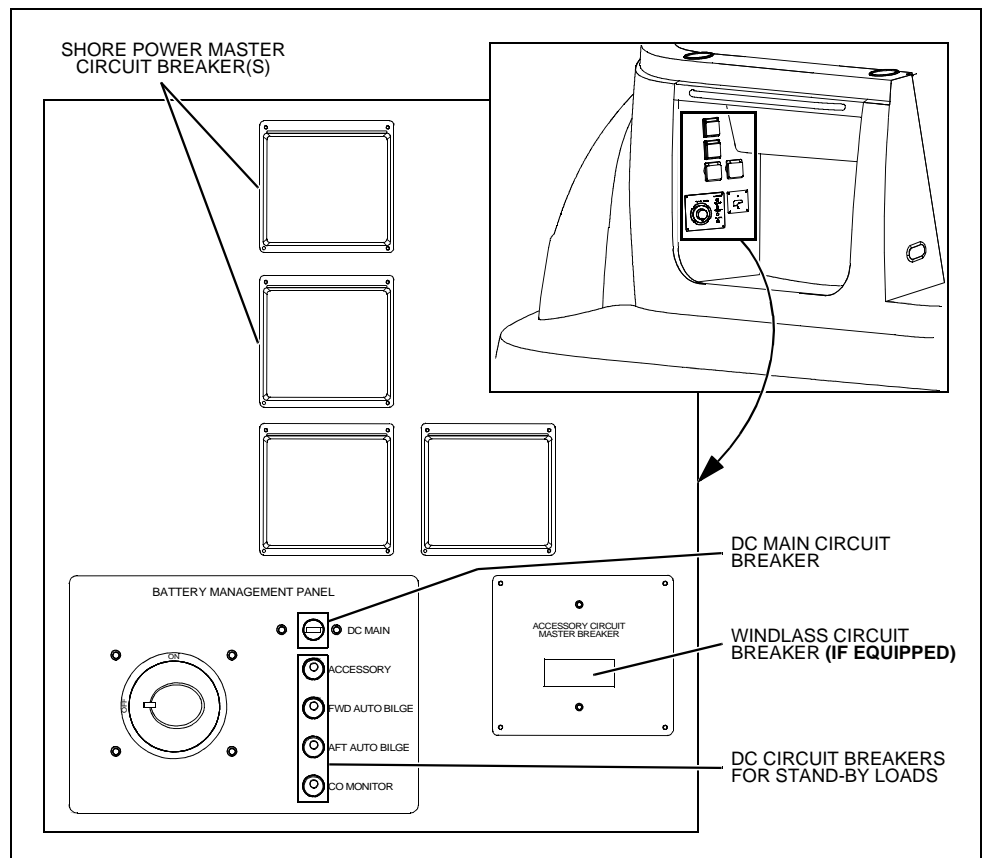

Depth Sounder Thru-hull Transducer:

- Located in the engine room, forward of the engine.

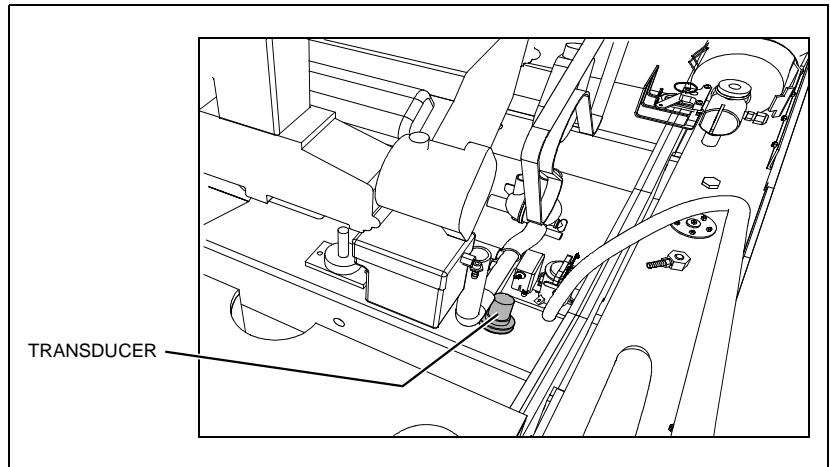

Engine Circuit Breaker:

- Located on the engine.

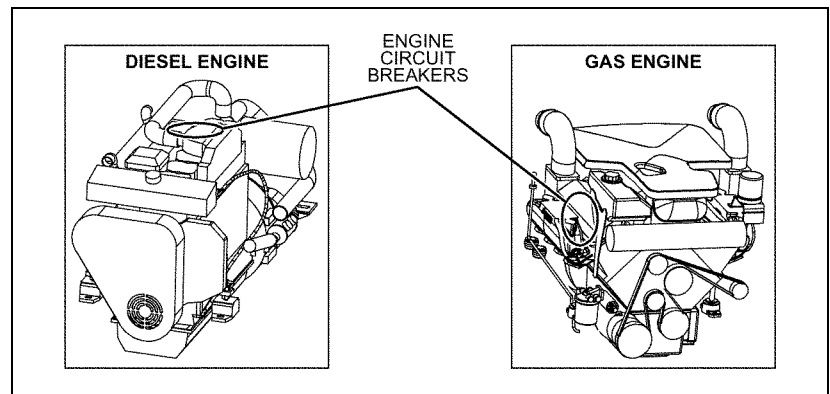

Fire Suppression System Manual Discharge T-Handle (If Equipped):

- Located to the right of the helm

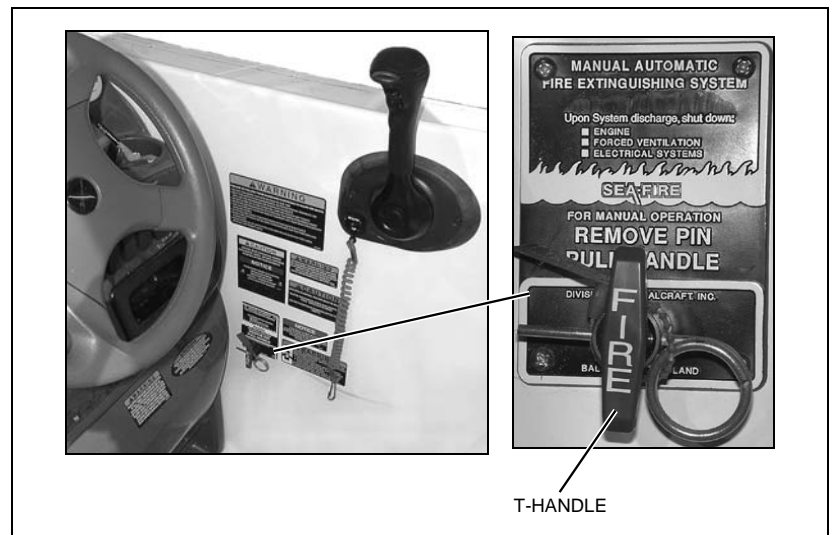

Freshwater Fill Vented Thru-hull Fitting:

- Located amidship on the starboard hullside, just below the gunnel.

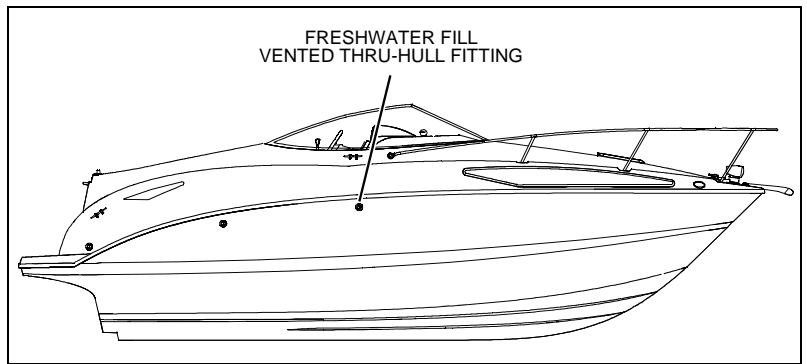
**Freshwater Pump:**

- Located under the bottom entry step.
- Access by lifting up the bottom entry step.

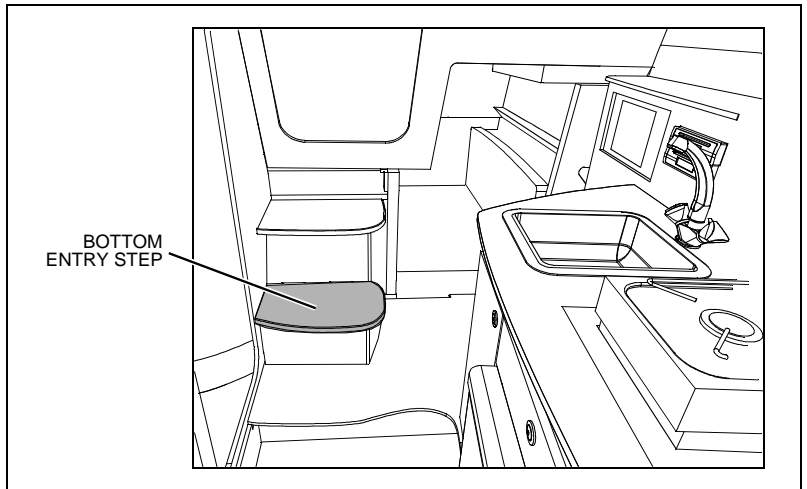
**Freshwater Pump Switch:**

- Located on the aft end of the lower galley cabinet.

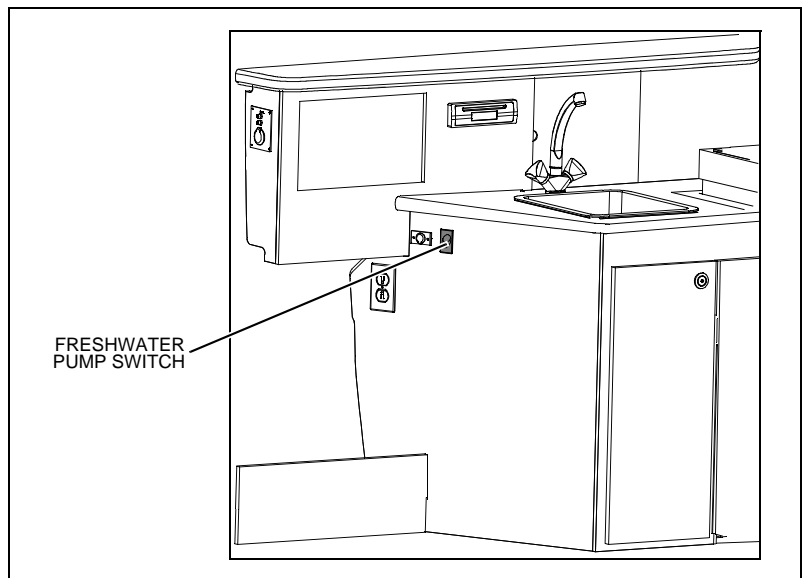

Freshwater Tank:

- Located amidship in the bilge.
- Access by lifting up the bottom entry step.

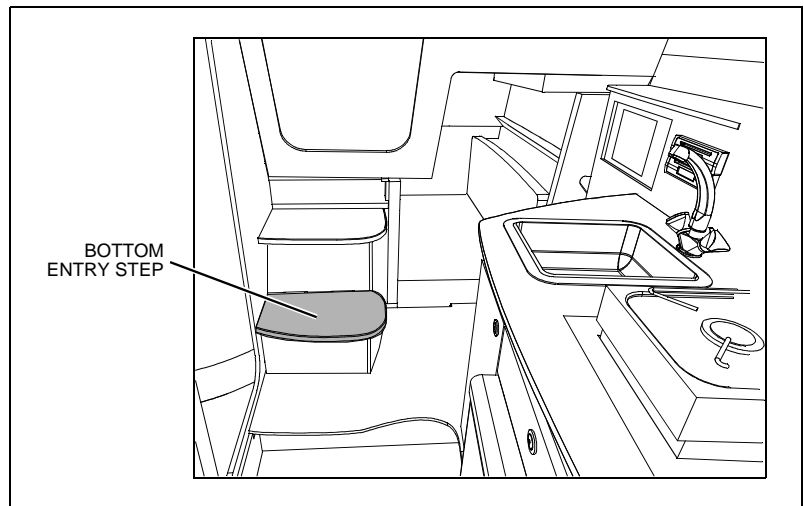
**Fuel Fill Vented Thru-hull Fitting:**

- Located on the starboard hullside, aft of the freshwater fill vented fitting.

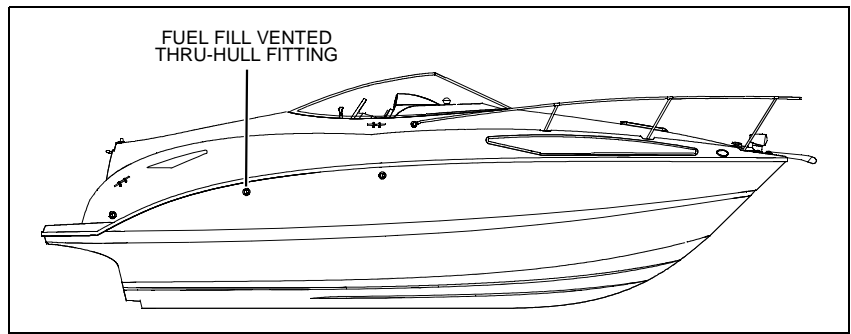
**Fuel Tank Fittings:**

- Located in the engine room.

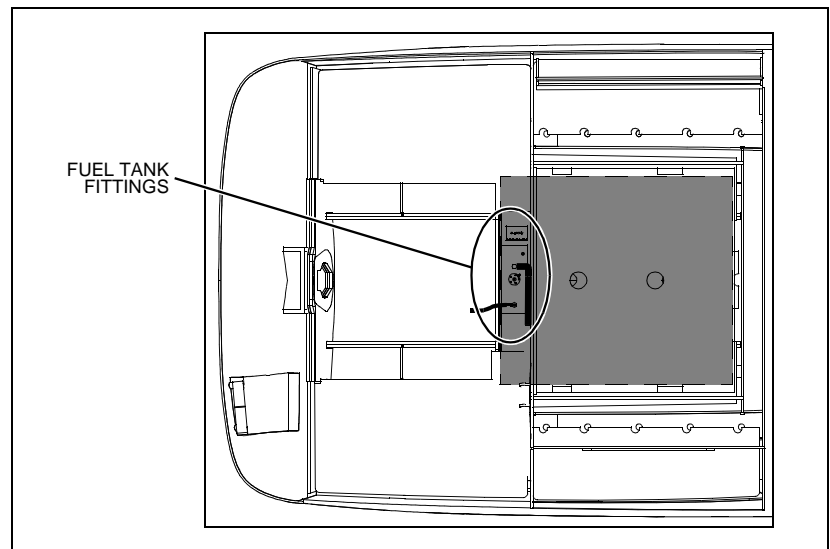

Fuse Blocks:

- Located inside the starboard wall hatch in the aft-berth.

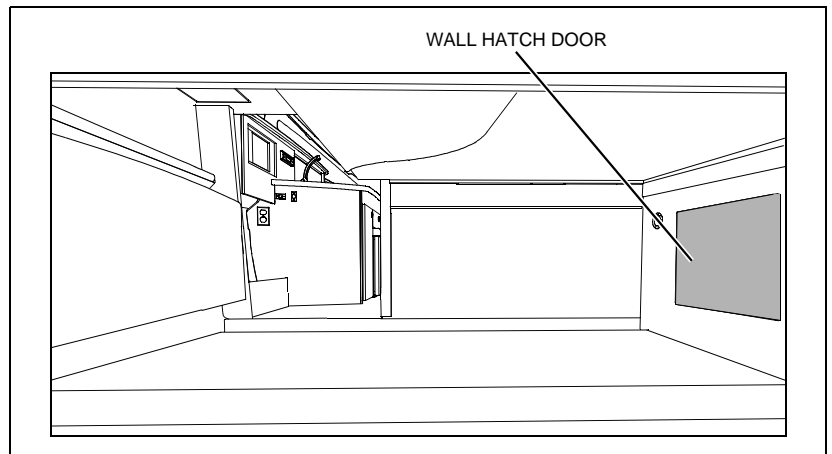

Macerator Switches (If Equipped):

- Located to the right of the helm.



Macerator Underwater Discharge Seacock (If Equipped)

- Located in the engine room, on the starboard aft wall.

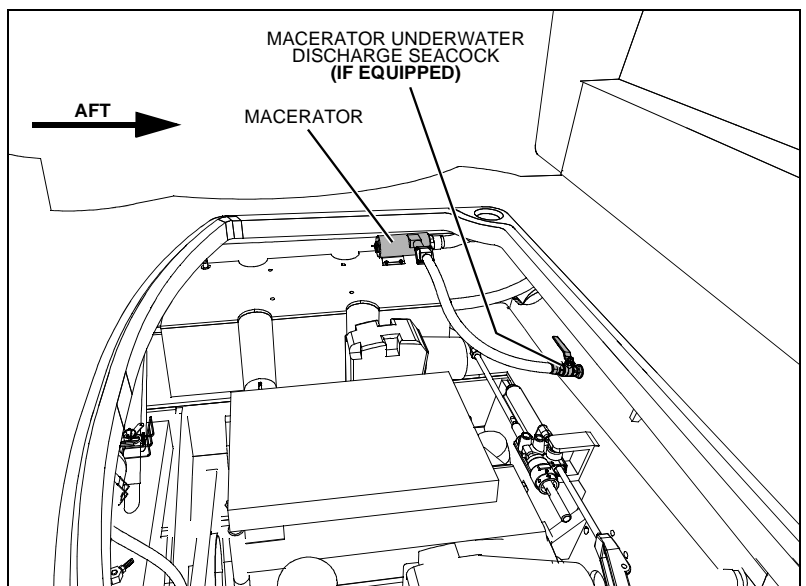

Marine Head Seawater Intake Seacock:

- Located under the bottom entry step.
- Access by lifting up the bottom entry step.

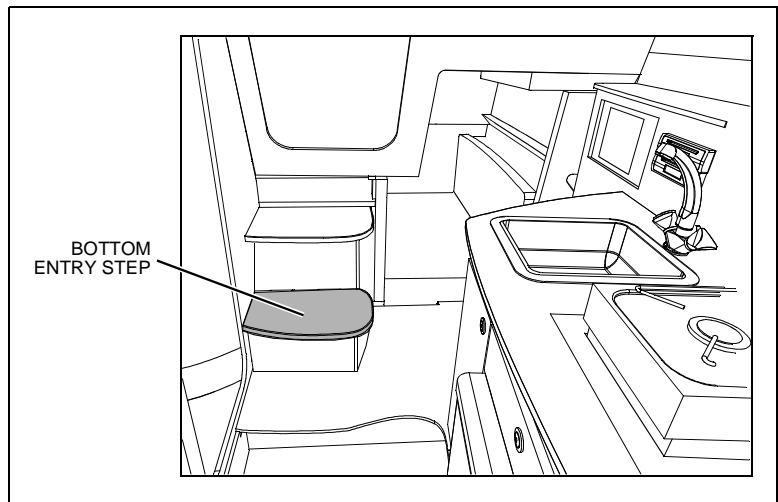
**Power Trim and Tilt Pump & Reservoir**

- Located in the port aft corner of the engine room.

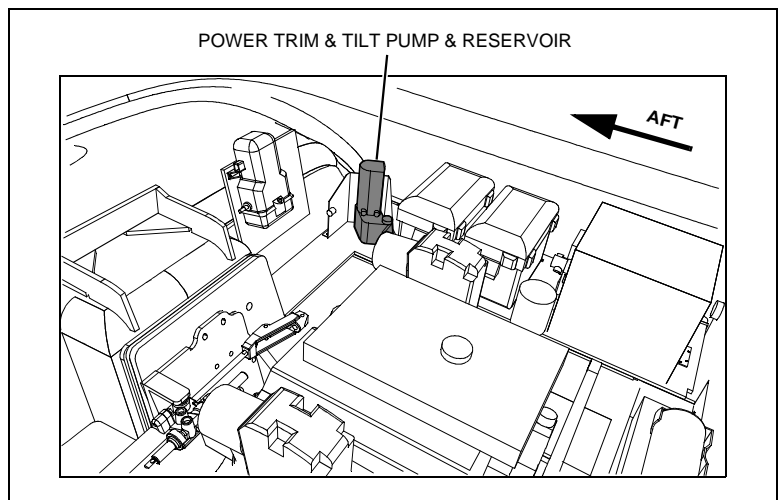
**Shore Power Inlet(s):**

- Located inside the transom storage locker.

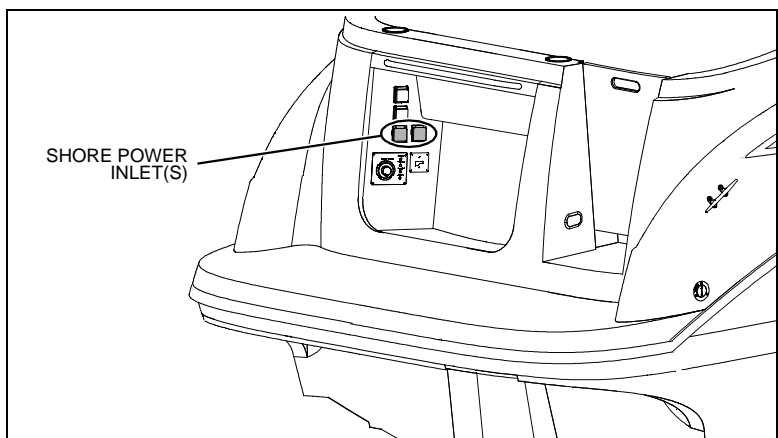

Shore Power Master Circuit Breakers (If Equipped):

- Located inside the transom storage locker.

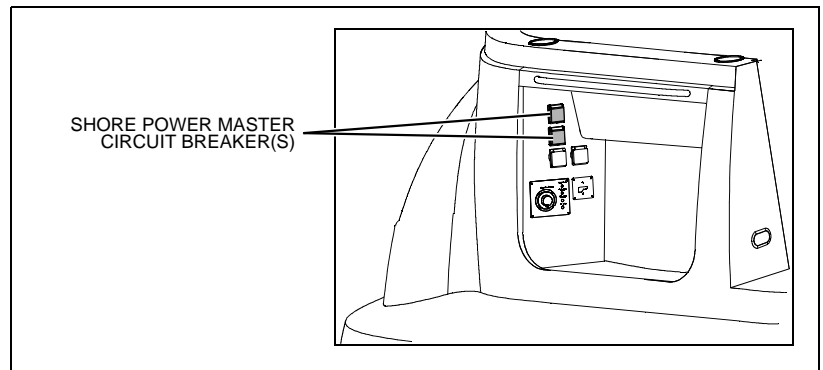

Shower Sump Pump Box:

- Located under the bottom entry step.
- Access by lifting up the bottom entry step.

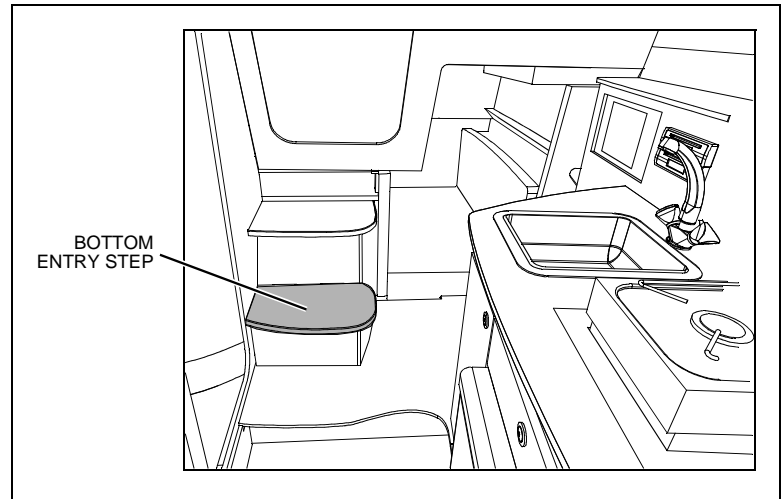

Spotlight (If Equipped):

- Located on the bow.

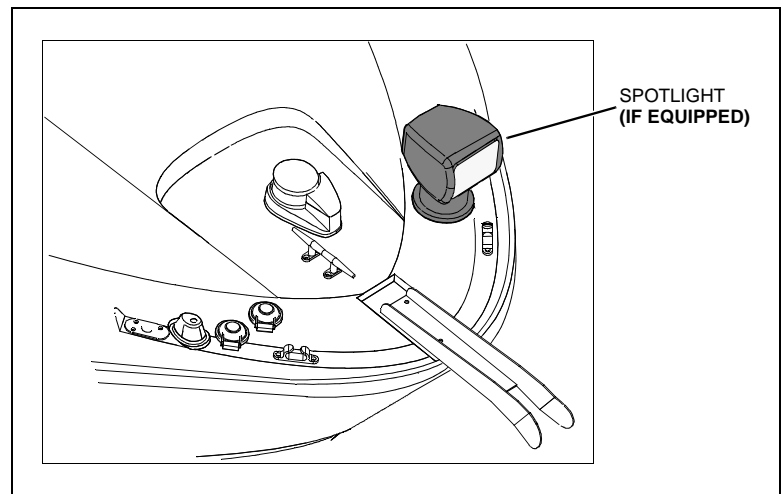

**Spotlight Control Panel
(If Equipped):**

- Located at the helm.

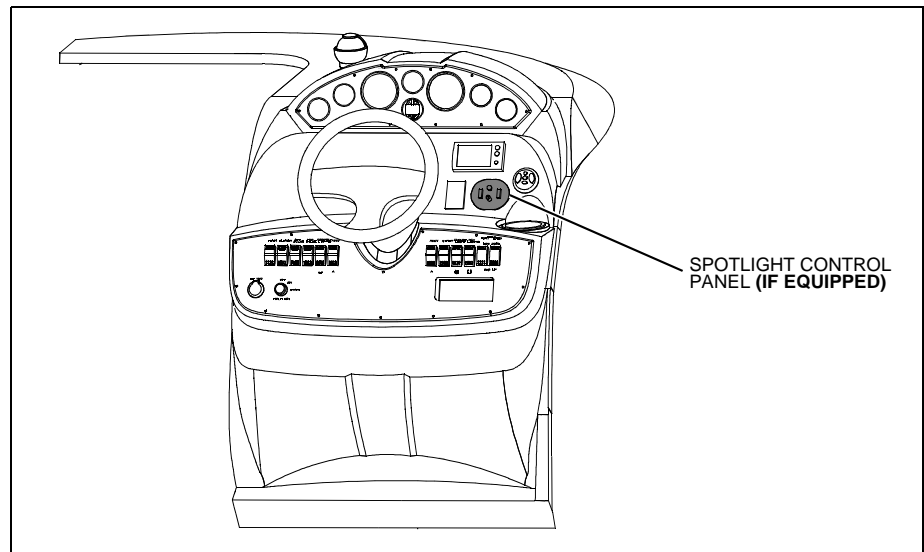
**Trim Tab Pump & Reservoir**

- Located on the port aft wall of the engine room.

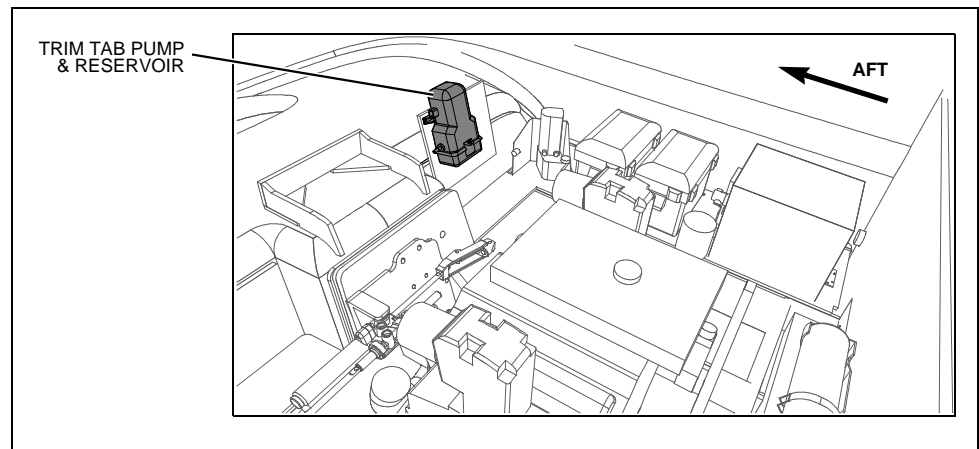
**Waste Holding Tank:**

- Located on the starboard side of the engine room.

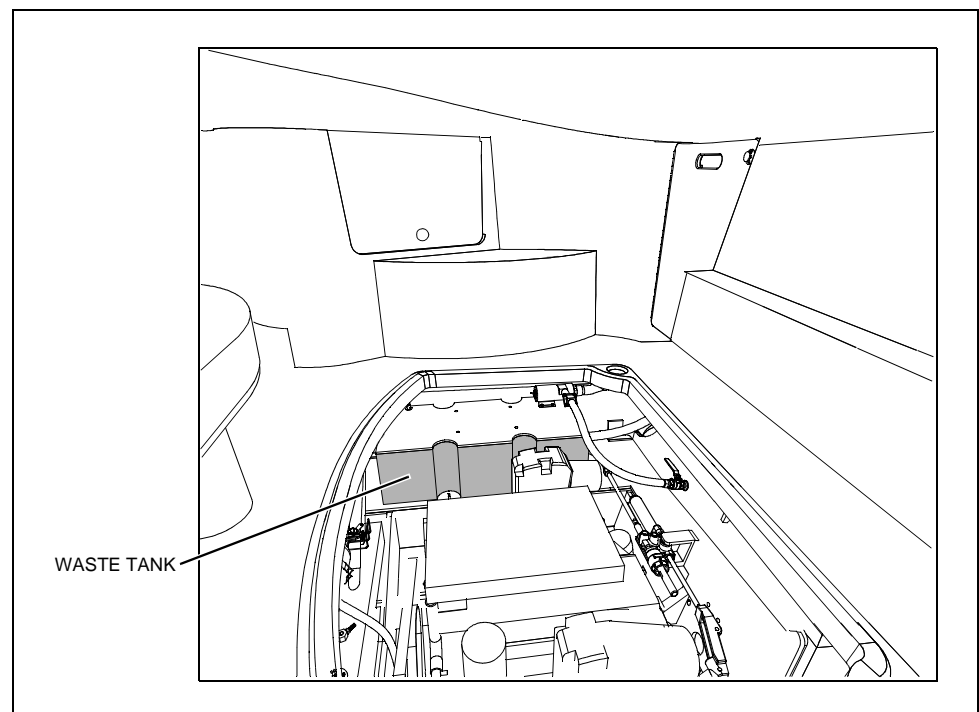

Waste Pump-Out Deck Fitting (If Equipped):

- Located on the starboard corner of the aft deck, just above the swim platform and next to the transom door.

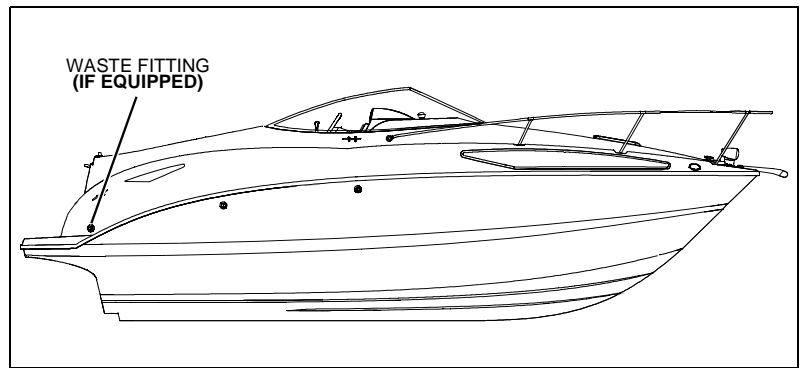
**Water Heater**

- Located in the port forward corner of the engine room.

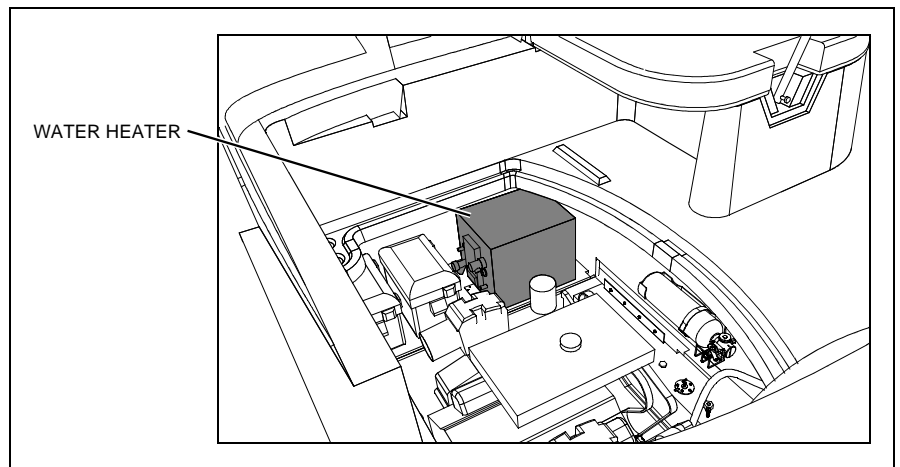

Chapter 3: Propulsion & Related Systems

Engine

Read the engine operation and maintenance manuals *before* starting or doing any maintenance on the engine.

Bilge Blower System

! **WARNING!**



FIRE/EXPLOSION HAZARD

- Use of the bilge blower system is *NOT A GUARANTEE* that explosive fumes have been removed.
- *BEFORE* starting the engine *ALWAYS* use the "sniff test" to check the engine and bilge areas for fuel vapors.
- If you smell fuel, do *NOT* start the engine and do *NOT* turn *On* any electrical devices.
- If you smell fuel and the engine is already running, shut *Off* the engine and turn *Off* all electrical devices. Investigate *immediately*.
- Do *NOT* obstruct or modify the bilge blower system.

- The bilge blower removes explosive fumes from the engine and bilge areas.
- Fresh air is drawn into the engine and bilge areas through the vents.

To make sure the engine and bilge areas are properly ventilated:

- Use the "sniff test" to check the engine and bilge areas for fuel vapors *before* starting the engine.
- *Always* run the bilge blower for at least four minutes *before* starting the engine.
- Continue to run the blower until your boat has reached cruising speed.
- *Always* run the blower when running the boat below cruising speed.

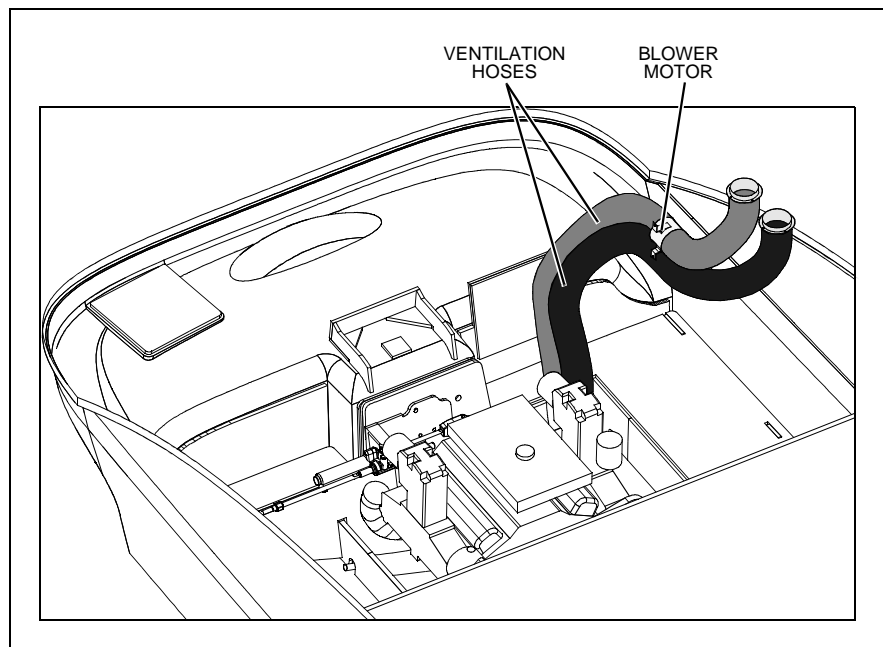

Fuel System

⚠ WARNING!

⚠ FIRE, EXPLOSION AND OPEN FLAME HAZARD!

- It is very important that the fuel system be inspected thoroughly the first time it is filled and at each subsequent filling.
- The fueling instructions in the *Cruiser & Yacht Owner's Manual* and the fuel recommendations in the engine operation manual *must* be followed.

⚠ CAUTION

Avoid the storage or handling of gear near the fuel lines, fittings and tank.

NOTICE

- On diesel engine models, air in the diesel supply system can stop an engine or severely restrict performance.
- If you suspect air in the fuel lines, refer to your engine operation manual for detailed instructions on how to *bleed* the system.

NOTICE

Carefully read the fuel section of both the *Cruiser & Yacht Owner's Manual* and the engine operation manual, paying special attention to the subject of *fuel recommendations*.

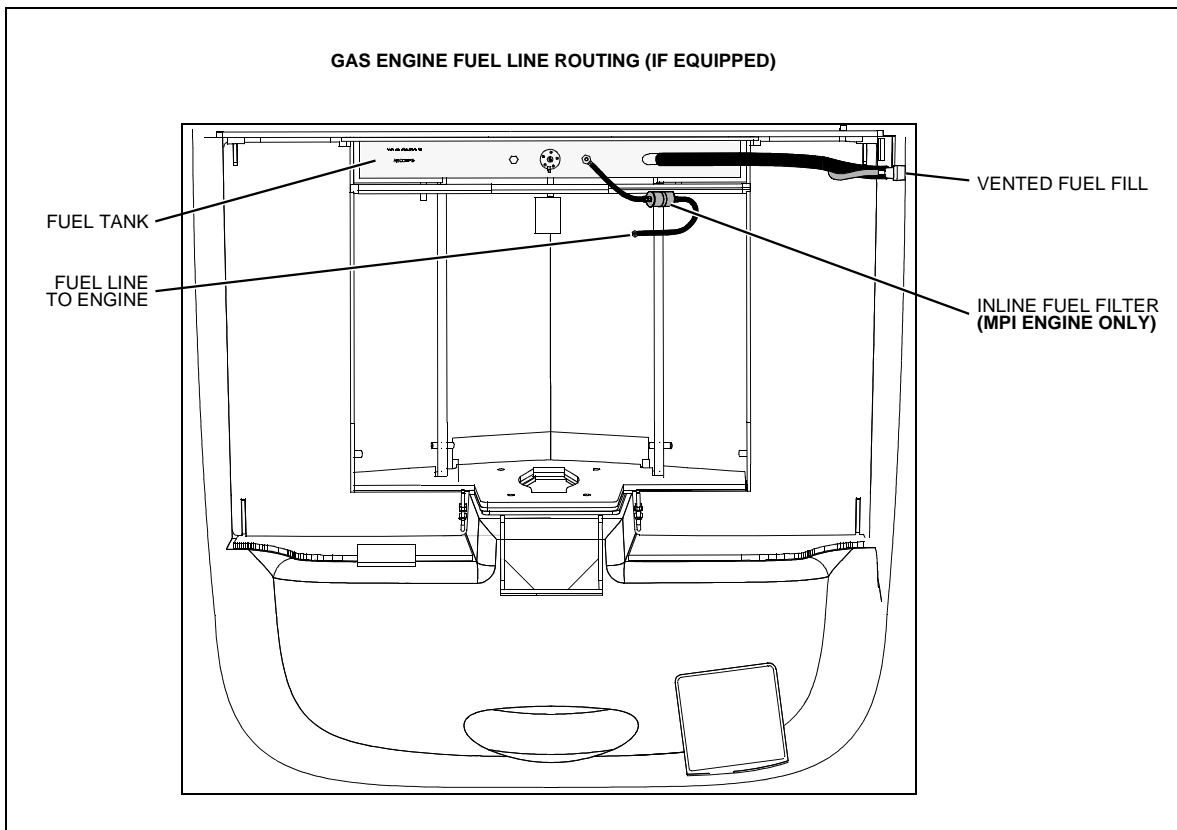

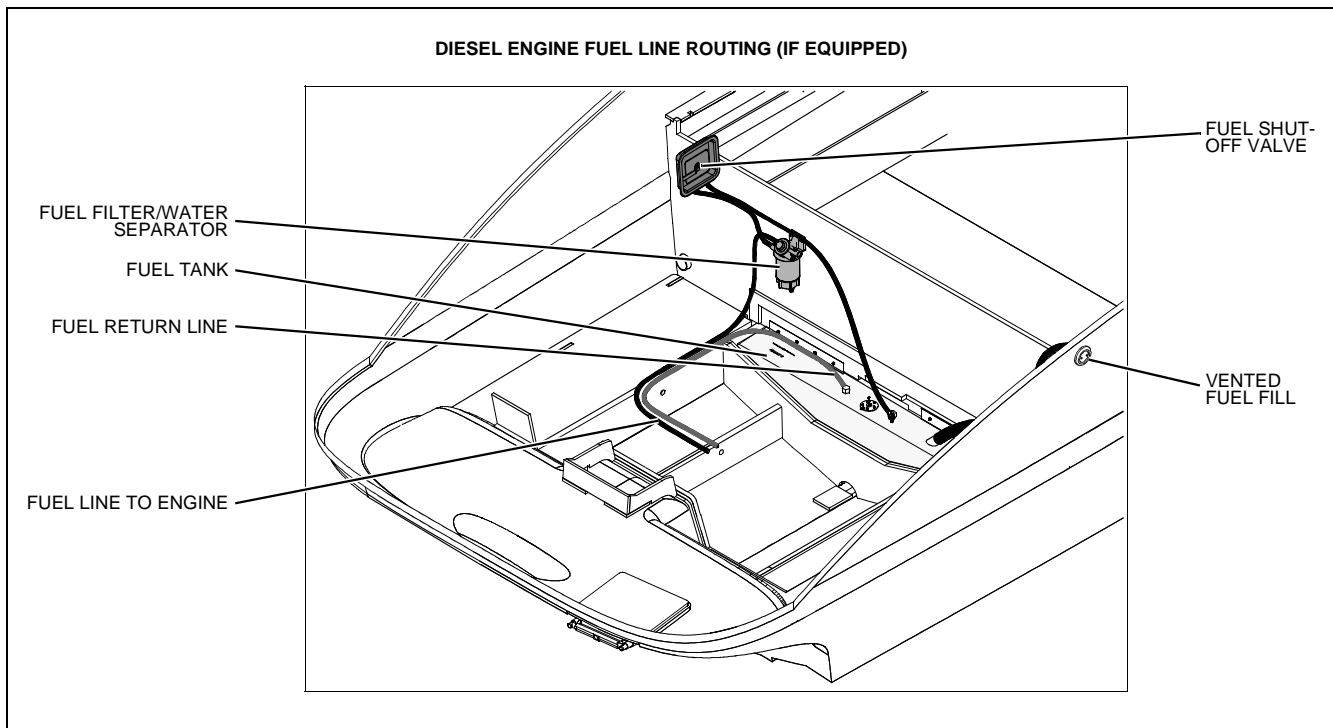

Fuel Fill & Vent

- The fuel fill fitting is marked "Gas" or "Diesel".
- If you have problems filling the fuel tank, see if the fuel fill hose or fuel tank vent hose is kinked or collapsed.
- If there are no visible signs of a problem, contact your local dealer.

Anti-siphon Valve (Gas Engine Only)

NOTICE

- **If an engine running problem is diagnosed as fuel starvation, check the anti-siphon valve.**
- **If the valve is stuck or clogged, change or replace it while the engine is *shut down*.**
- ***NEVER* run the engine with the anti-siphon valve removed, except in an emergency.**

- The fuel pickup tube, located inside the fuel tank, is equipped with a fine mesh screen filter.
- If your boat features an MPI engine, the fuel system has an inline fuel filter on the fuel line.
- In addition, when supplied by the engine manufacturer, a fuel filter is installed on the engine.
- Periodically replace the fuel filters to make sure they remain clean and free of debris.
- Talk to your selling dealer or local marina about fuel additives that help prevent fungus or other buildup in your gas fuel tank.

Gas Engine Fuel Filters

- The fuel pickup tube, located inside the fuel tank, is equipped with a fine mesh screen filter.
- MPI engine fuel systems include an inline fuel filter.
- In addition, when supplied by the engine manufacturer, a fuel filter is installed on the engine.
- Periodically replace the fuel filters to make sure they remain clean and free of debris.
- Talk to your selling dealer or local marina about fuel additives that help prevent fungus or other buildup in your gas fuel tank.

Fuel Filter/Water Separator (Diesel Engine Only)

NOTICE

- **The frequency of water draining or element replacement is determined by the contamination level in the fuel.**
- **Inspect the collection bowls for water daily.**
- **Replace the elements at least once a year, or when a loss of power is noticed, whichever comes first.**

- The fuel feed line features a fuel filter/water separator.
- Service instructions for the fuel filter/water separator is provided on the filter.

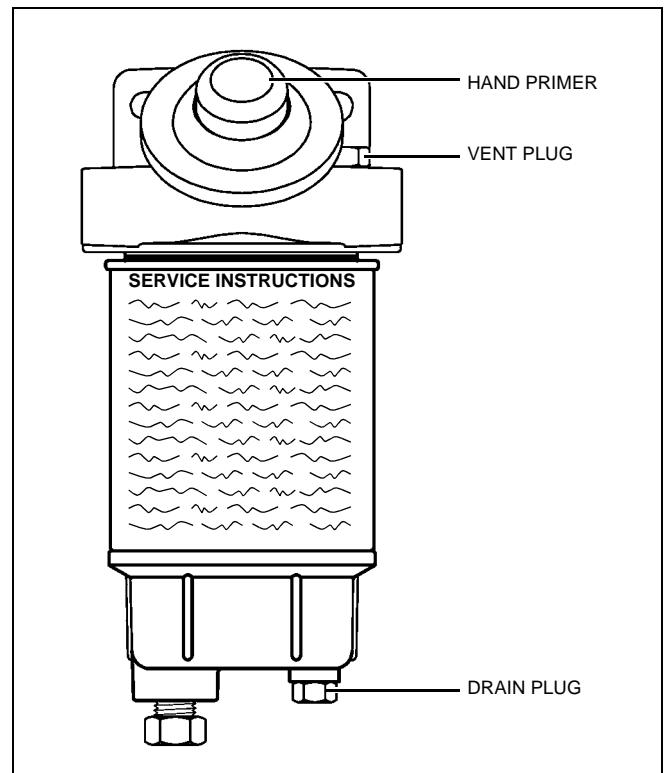

Quick Oil Drain System (Gas Engine Only)

The quick oil drain hose was attached to the engine oil pan at the factory. However, some minor assembly is still needed *before* you can use this system.

How to install the quick oil drain system:

1. Unscrew the factory installed garboard drain plug from the garboard drain (A). Keep the factory garboard drain plug on the boat as a spare.
2. Un-clip the quick oil drain assembly from the wire loop (B) on the engine.
3. Un-clip the draw cord section (C) from the draw cord section (D).
4. Thread the draw cord section (D), the oil drain plug (E), and the oil drain hose (F) through the garboard drain (A).
5. Adjust the hose stop clamp (G) so that no more than 12 inches of hose, including the oil drain plug, can extend out of the garboard drain (A).
6. Re-clip the draw cord section (C) to the draw cord section (D).
7. Push the oil drain hose, oil drain plug, and both sections of the draw cords through the garboard drain and into the bilge area.
8. Screw the oil drain garboard drain plug (H) into the garboard drain (A) and tighten firmly.

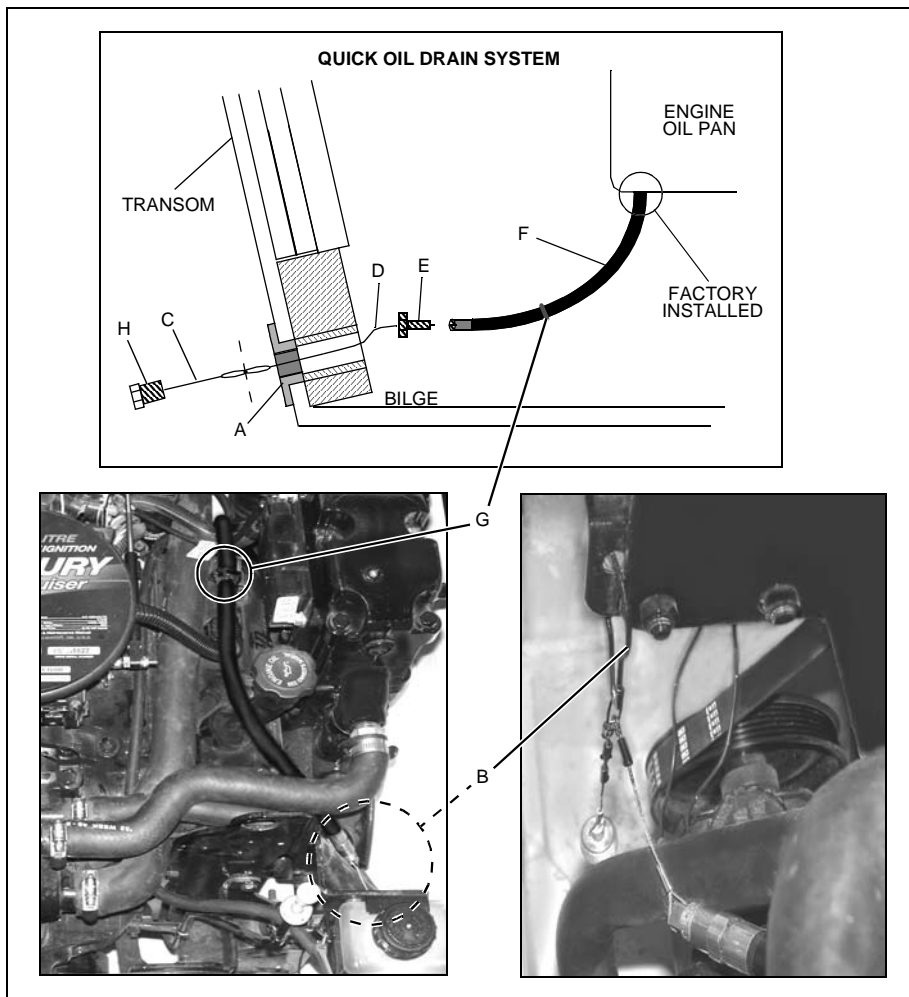

To drain the engine oil:

1. Remove the boat from the water.
2. Unscrew the garboard drain plug.
3. Pull the draw cord until the oil drain plug and the oil drain hose slide out of the garboard drain.
4. Place the end of the oil drain hose into a suitable container.
5. Unscrew the oil drain plug and drain the engine oil.
6. Replace the oil drain plug.
7. Push the drain hose back into the bilge.
8. Replace the garboard drain plug and tighten firmly.

Always dispose of waste oil in accordance with local regulations.

Fire Suppression System (If Equipped)

- The fire suppression system is designed to extinguish engine compartment fires.
- **Before** using your boat for the first time, read the fire suppression system's instruction and maintenance manual and follow **all** warnings.
- The system will discharge automatically whenever direct heat from a fire is detected in the engine compartment.
- The system can be discharged manually by pulling the T-handle (labeled "FIRE") at the helm.
- The system can **only** be discharged **once**.
- After the system is discharged it **must** be refilled and refurbished **before** it can be used again.

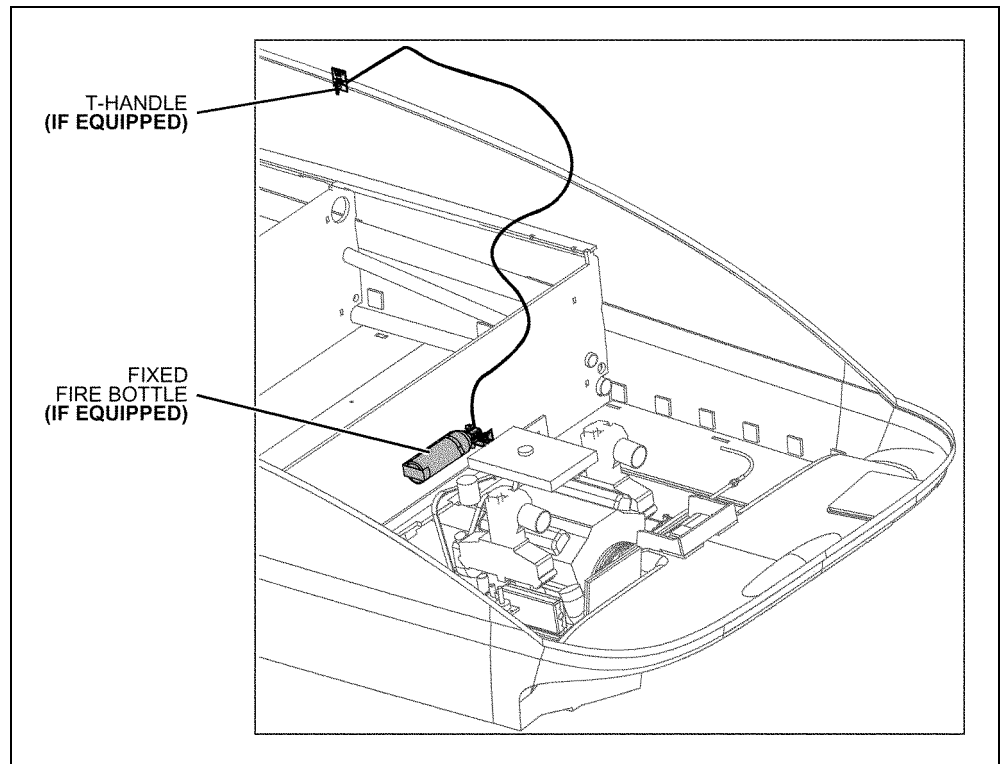

Chapter 4: Controls & Gauges

Steering

- This boat features a power assisted rack-and-pinion steering system.
- For information about the 'power assist fluid reservoir', refer to the engine operation and maintenance manual.
- Boat steering is *not* self-centering.
- Refer to the engine manual for more steering system details.

Shift/Throttle Control

 WARNING!
LOSS OF CONTROL HAZARD!
Improper maintenance of shift/throttle hardware may cause a sudden loss of control!

- Read *all* of the information about the shift/throttle control in the *Cruiser & Yacht Owner's Manual*.
- Also, read the shift/throttle controls' manual and the engine manual.

Power Trim and Tilt

- The stern drive on your boat is equipped with power trim and tilt.
- Trim and tilt instructions are provided in the engine operation manual and the shift/throttle control manual.

Trim Tabs

⚠ **WARNING!**

LOSS OF CONTROL HAZARD!

Improper use of trim tabs *will* cause loss of control!

- Do **NOT** allow anyone unfamiliar with trim tabs to use them.
- Do **NOT** use trim tabs in a following sea as they *will* cause broaching or other unsafe handling characteristics.
- Do **NOT** use trim tabs to compensate for excessive unequal weight distribution.

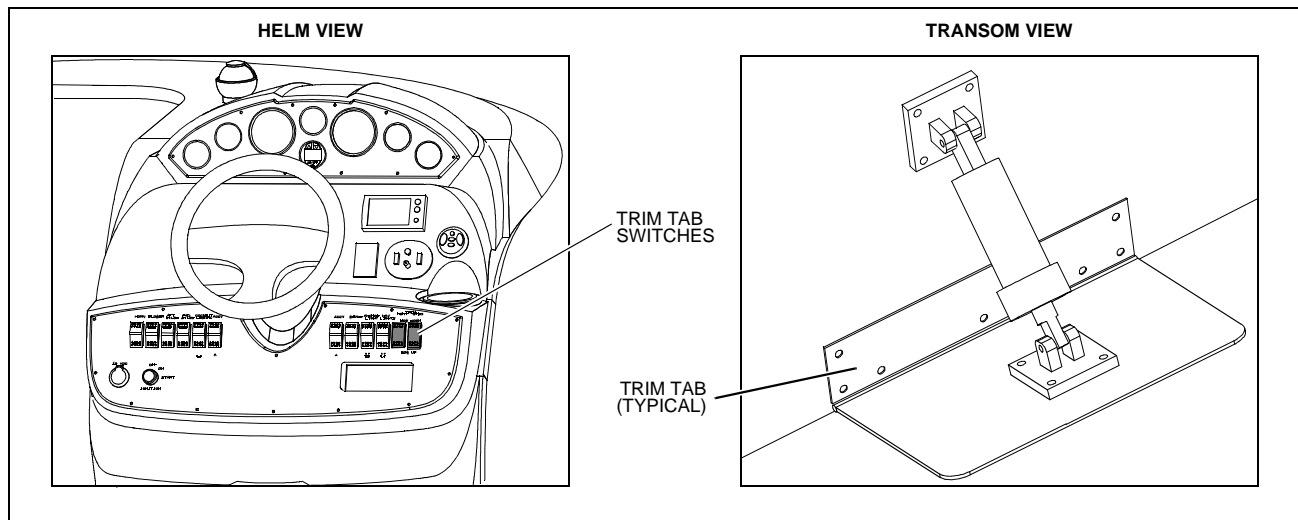

- **Before** using the trim tabs read the trim tab operation manual.
- The trim tabs can be used to help keep your boat level at cruising speeds.
- The trim tabs are controlled by two rocker switches at the helm.
- Once cruising speed is reached, the port or starboard trim switch may be used (one at a time) to level the boat.
- Perform trim tab adjustment with several short touches to the switch rather than one long one.
- After each short touch allow several seconds for the hull to react.
- Periodically (at least once a year) check the fluid level in the trim tab hydraulic fluid reservoir and refill as necessary. For the location of the fluid reservoir see the Component Locations section of Chapter 2 in this *Supplement*.

Gauges

Cleaning Gauges

 CAUTION
<i>PRODUCT or PROPERTY DAMAGE HAZARD!</i>
<ul style="list-style-type: none">• Use only mild soap and water to clean the gauge lenses and bezels.• Use of other cleaners, including common window cleaning solutions, may cause the lenses to crack.• Lenses cracked in this manner will NOT be covered by our warranty.

Gauge Fogging

- Moisture may occasionally find its way into the gauges causing lens fogging.
- Turning **On** the gauge lights will help dry the lenses.
- Fogging will not harm the gauges.

Radio Transmission Interference

VHF or other radio transmissions may cause brief erratic readings on the tachometer. This will not damage the tachometer gauge or affect its accuracy when not transmitting.

Fuel Gauge

It is normal for the pointer on your fuel gauge to bounce as fuel sloshes back and forth in the fuel tank.

Chapter 5: Navigation & Communication Equipment

Read the manuals for *all* navigation & communication equipment *before* using these systems.

Compass

NOTICE

- **Compass accuracy can be affected by many factors.**
- **Have a qualified technician calibrate your compass.**
- **Make sure the technician gives you a deviation card which shows the corrections to apply in navigational calculations.**
- **Keep a copy of the deviation card at the helm.**

Depth Finder



WARNING!

- **Do *NOT* use the depth finder as a navigational aid to prevent collision, grounding, boat damage or personal injury.**
- **When the boat is moving, submerged objects *will not* be seen until they are already under the boat.**
- **Bottom depths may change too quickly to allow time for the boat to react.**
- **If you suspect shallow water or submerged objects, run the boat at very slow speeds.**

VHF Radio (If Equipped)

- Your boat may include a VHF (Very High Frequency) radio.
- The VHF radio can be used to access weather reports, summon assistance or contact other vessels as permitted by the FCC (Federal Communications Commission).
- Contact the FCC for licensing, rules and regulations concerning VHF radio usage.

Chapter 6: Plumbing

Bilge Pumps

NOTICE

Discharge of oil, oil waste or fuel into navigable waters is prohibited by law. Violators are subject to legal action by the local authorities.

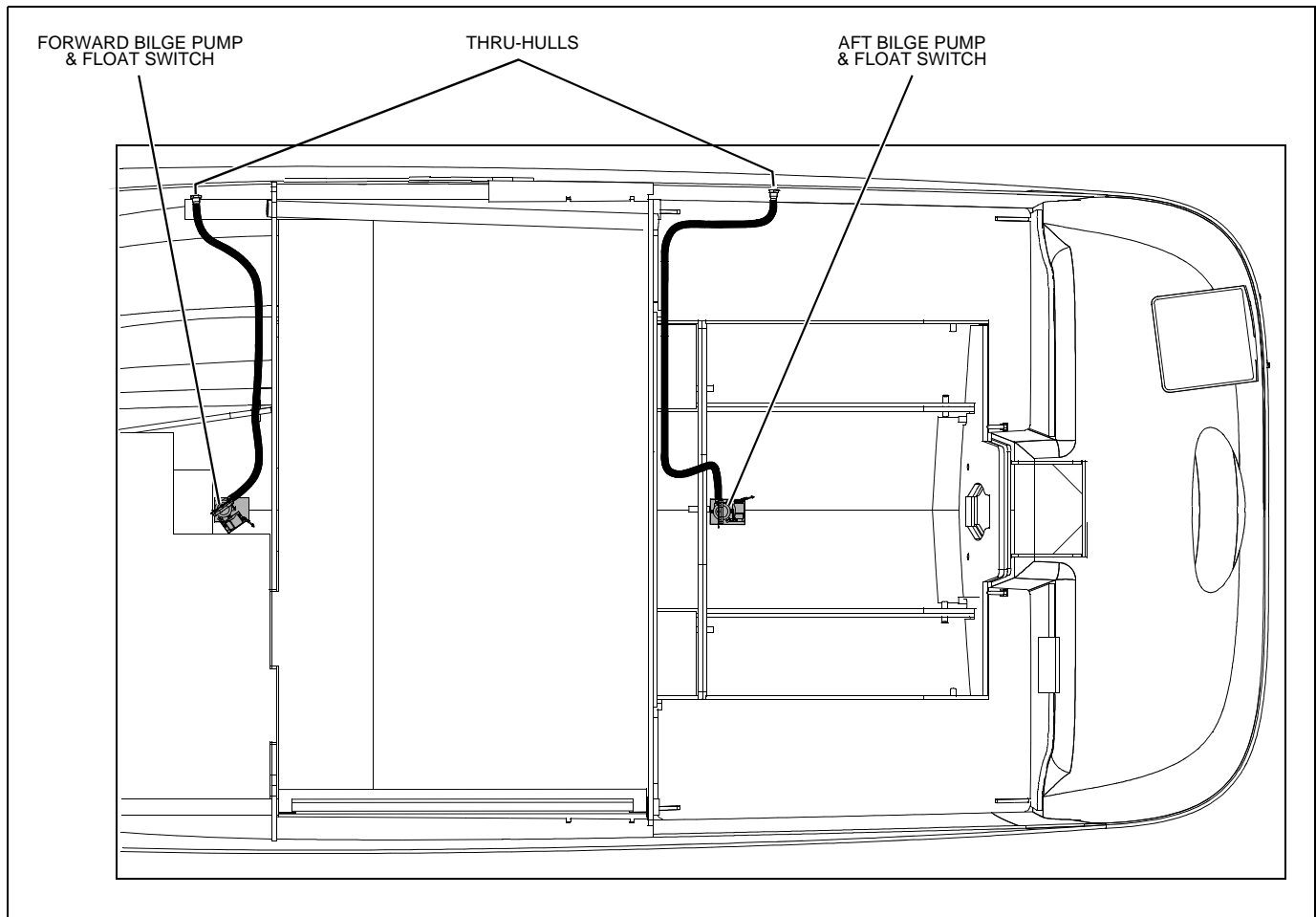

- Your boat is equipped with two bilge pumps for pumping water out of the bilge.
- The bilge pumps are controlled by automatic float switches (autofloat switches) and/or switches at the helm.
- The bilge pumps are wired directly to the battery.
- Unless the battery is dead, the pumps should work even when the boat is unattended.

Bilge Pump Testing

- The bilge pumps are vital to the safety of your boat.
- Test the bilge pumps often to make sure they are working properly.

Testing process:

1. One at a time, turn *On* each bilge pump switch at the helm.
 2. Make sure that water in the bilge is pumped overboard.
- If there is water in the bilge and the pump motor is running, but *not* pumping, inspect the discharge hose for a kink or collapsed area.
 - If the discharge hose looks okay, check the bilge pump housing for clogging debris.

Checking for clogging debris:

1. Remove the pump motor from the housing:
 - a. Lift the tab while rotating the fins counter-clockwise.
 - b. Lift out the pump motor.
 - c. Clear the housing of debris.
2. Reinstall the pump motor:
 - a. Make sure the "O" ring is properly seated.
 - b. Coat the "O" ring with a light film of vegetable or mineral oil.
 - c. Align the cams on either side of the pump motor with the slots on the housing.

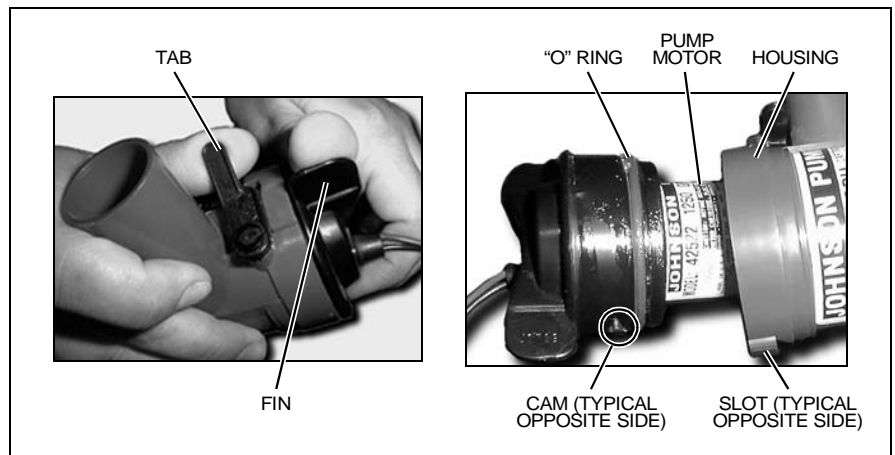

- d. Press the pump motor into the housing while twisting clockwise.
3. Check the reinstallation by trying to twist the fins counter-clockwise *without* lifting the tab; the pump motor should stay in place.

Autofloat Switches

- The automatic bilge pumps use float (autofloat) switches to automatically turn **On** the pumps whenever water rises to a preset level in the bilge.
- The autofloat switches are normally mounted next to the bilge pumps they control.
- The autofloat switches should be tested often as follows.

Autofloat testing:

1. Lift the float switch test button **up** to turn **On** the bilge pump.
 - If the pump does **not** turn **On**, check the fuse on the fuse block.
 - If the fuse is good but the switch still doesn't work, it may mean the switch is bad or possibly the battery is low.
2. After testing, push the test button all the way **down** to return the float switch to auto mode.

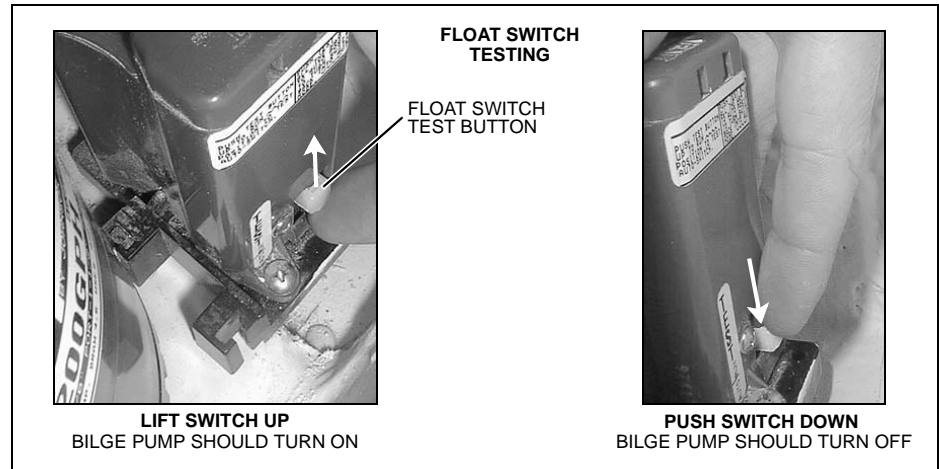

CAUTION!

When the test is completed on each float switch, you **MUST** push the test button *all the way down* to return the switch to auto mode!

Seawater Systems

Seacocks



CAUTION

SYSTEM DAMAGE HAZARD!

- **Before** using a seawater intake system, make sure that the system's seacock is in the *Open* position **before** the system is started and keep the seacock *Open* until the system is shut *Off*.
- **Close** the seacocks whenever the systems will *not* be used for long periods of time.

A seacock is a thru-hull valve, that may be opened to let in seawater or discharge liquids such as waste from the holding tank. Seacocks are typically used on your boat in the following seawater intake or liquid discharge systems:

- Air conditioning system (if equipped)
- Marine head system (if equipped)

Before using any of these systems, make sure that the system's seacock is *Open* and remains *Open* until the system is shut *Off*.

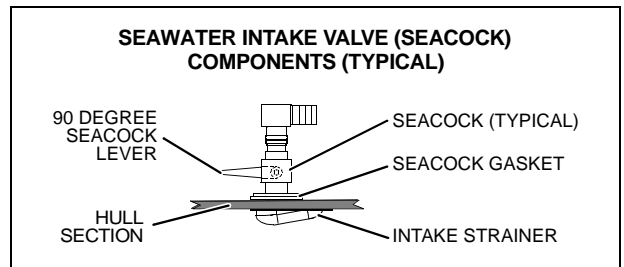

Seawater Strainers

- Seawater strainers are used in seawater intake systems to filter incoming seawater.
- A seawater strainer is located near each system's seacock.
- Check the strainers for leaks and/or debris **every time** you use your boat.
- If debris is found, clean the seawater strainer as follows:



CAUTION

FLOODING HAZARD!

- The seacock that sends seawater to the strainer must be **CLOSED** before disassembling the seawater strainer to prevent the boat from taking on water through the seawater strainer assembly.
- Keep the seacock **CLOSED** until the seawater strainer is completely reassembled.

SYSTEM DAMAGE HAZARD!

- After reassembling the seawater strainer, make sure that the seacock valve is **OPEN** before using the component/system.

1. Make sure the component/system (marine head, air conditioning system, etc.) that the strainer is connected to is turned *Off*.
2. **Close** the seacock that sends seawater to the strainer you are about to clean. The seacock must remain **Closed** until the strainer is completely reassembled.
3. Take apart the seawater strainer.
4. Remove the debris.
5. Flush the strainer with water.
6. Reassemble the seawater strainer.
7. **Open** the seacock and check for leaks around the strainer. If no leaks are found, you may use the component or system.

Freshwater System



WARNING!

- **Only** use safe drinking (potable) water in your boat's freshwater system.
- **Only** use an FDA approved, white 'drinking water safe' hose to fill the freshwater tank.
- **NEVER** use a common garden hose for drinking water.

- Read the *Freshwater system* section in the *Cruiser & Yacht Owner's Manual*.
- Your boat is equipped with a pressure type (demand) freshwater (potable) system.
- This system can be pressurized by turning **On** the freshwater pump.
- See the *Locations* section of this *Supplement* for the location of the freshwater pump switch.
- Since the freshwater pump requires DC power, the battery switch **must** be turned **On** for the pump to work.
- Turn **Off** the freshwater pump when the boat is **not** in use or when the freshwater tank is empty.
- Inspect and clean the freshwater filter often (located on the freshwater pump).
- If your boat is to be left unattended for a long period of time, pump the freshwater tank dry to prevent stored water from becoming stagnant and distasteful.
- If the freshwater system needs to be disinfected, ask your dealer about treatments available for your boat's system.

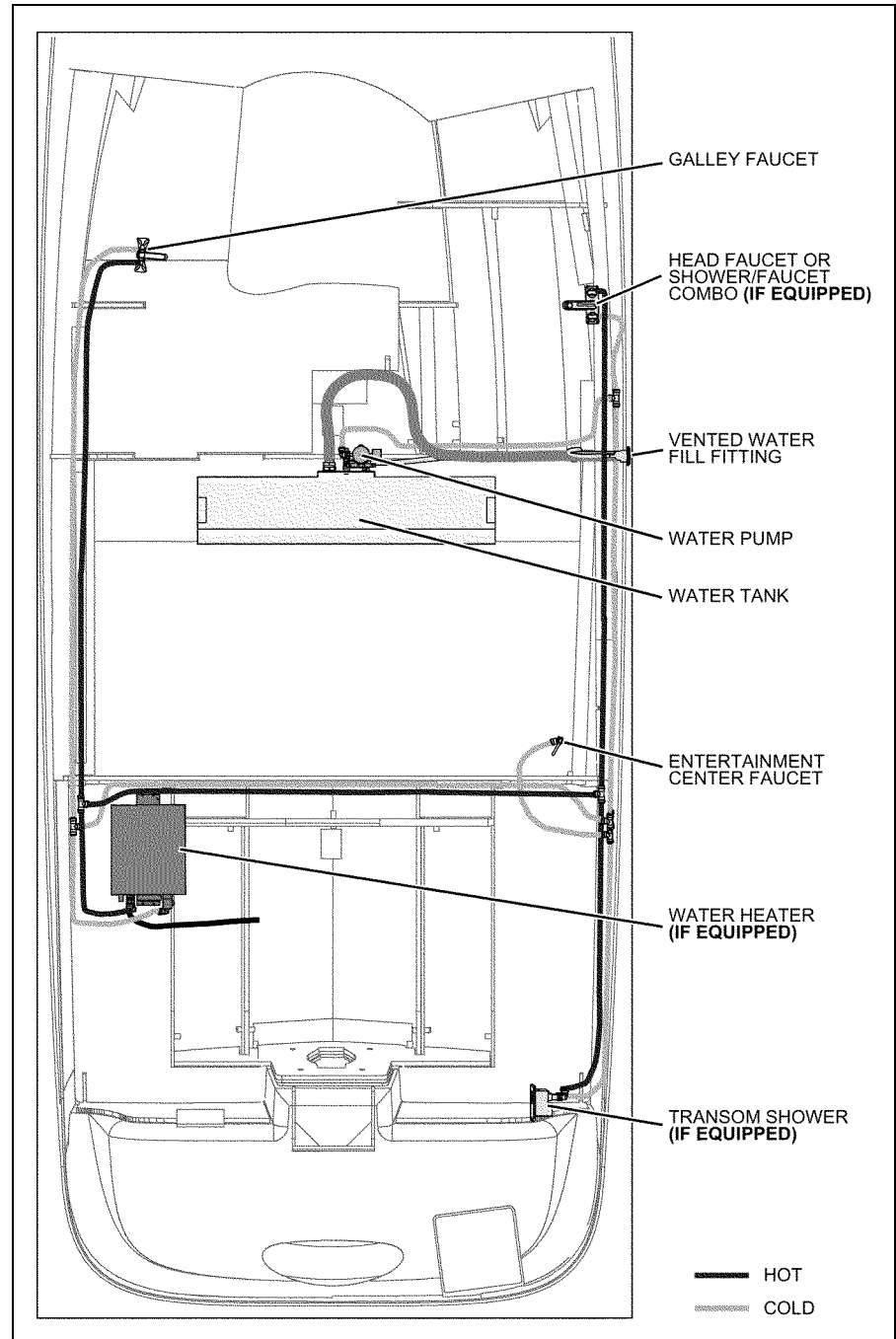

Freshwater System Winterization

CAUTION

WATER SYSTEM DAMAGE HAZARD!

NEVER blow compressed air through the water system when *all* of the faucets are *Closed*.

1. Turn **On** the freshwater pump switch.
2. **Open all** of the faucets and showers and let the freshwater system drain completely.
3. Turn **Off** the freshwater pump switch.

All remaining water **must** be removed from the water lines. There are two ways to remove the remaining water from the lines:

- Compressed Air
- Gravity Draining

Compressed Air

You **must** have an air compressor with an air hose and an air nozzle.

1. Remove the water line from the outlet side of the freshwater pump (opposite side from filter).
2. **Open** the faucet that is furthest away from the freshwater pump.
3. Place the air nozzle against the end of the just removed water line and blow air through the system.
4. When water stops coming out of the **Open** faucet, stop the air and **Close** the faucet.
5. One at a time, repeat this process on **all** faucets and showers.

Gravity Draining

1. **Open all** faucets and showers.
2. Remove the drain plug from the tee fitting on the freshwater tank.
3. When the water has stopped draining from the freshwater tank, replace the drain plug.

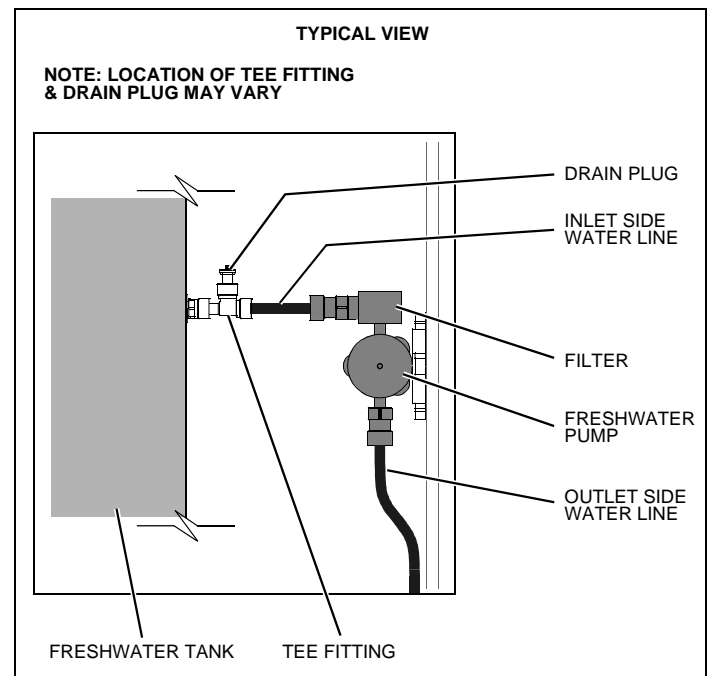

Water Heater (If Equipped)

⚠ WARNING!

⚠ SCALDING HAZARD!
Water heated by the water heater can be hot enough to scald the skin.

⚠ CAUTION!

WATER HEATER DAMAGE HAZARD!

- Do **NOT** turn **On** the water heater electrical circuit on the AC panel until the water heater tank is **COMPLETELY** filled with water.
- Even momentary operation in a dry tank *will* damage the heating elements.
- Warranty replacements will **NOT** be made on elements damaged in this manner.
- The tank is full if water flows from the tap when the hot water is turned **On** in the galley.
- The water heater should be drained and the power turned **Off** when the possibility of freezing exists.

NOTICE

If your boat is connected to shore power, but the water heater is *not* working:

- Make sure the water heater circuit breaker on the AC panel is switched **On**.
- If the circuit breaker on the AC panel is **On**, but the water heater is still *not* working, ask your dealer how to check the 'push to reset' circuit breaker located on the water heater.

- Read the water heater instruction manual and heed the warnings above.
- The water heater is connected to the 110-volt, AC power system.
- Turn **On** the water heater breaker on the AC panel to heat the water.

Winterizing the Water Heater

1. Turn **Off** the water heater breaker.
2. Disconnect the hose (A) attached to the pressure relief valve (B).
3. If there is any water in this hose, drain it into the bilge or into a bucket.
4. **Open** the pressure relief valve (B).
5. **Open** the drain valve (C).
6. Leave the pressure relief and drain valves **Open** until you fit out the boat after storage.

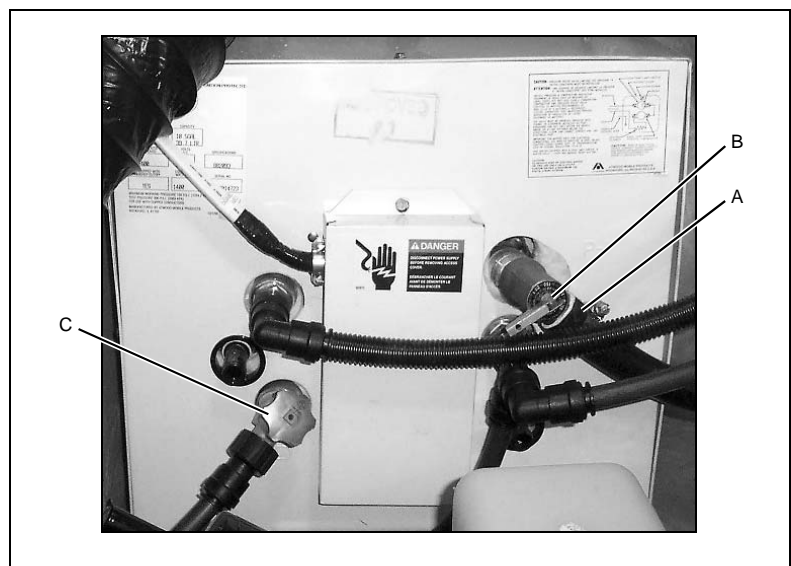

Transom Shower (If Equipped)

- Read the manufacturer's instructions *before* using the transom shower for the first time.
- The freshwater pump switch *must* be turned *On before* using the transom shower.

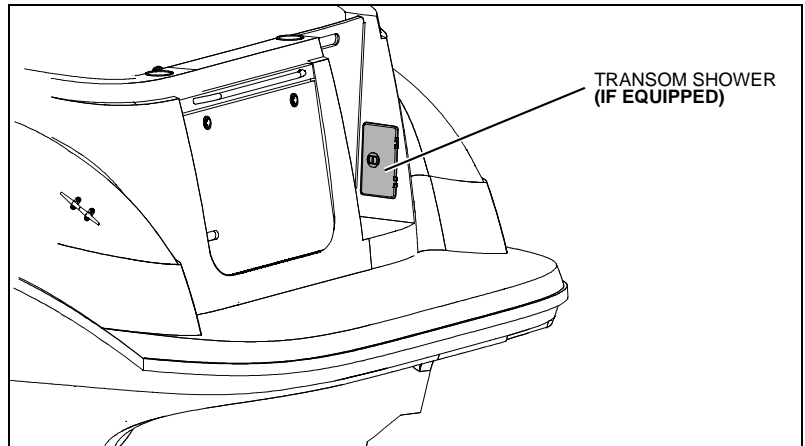

Drain Systems

Deck Drains

- Water on the deck is drained overboard through the deck drains.
- Keep the deck drains free of debris.

Gray Water Drains

The sinks are above the waterline and are gravity drained overboard

Shower Drain System (If Equipped)

- The shower drains into a sump pump box.
- The sump pump box has an autofloat switch.
- When the drain water rises to a preset level, the autofloat switch turns *On* the sump pump, and the drain water is pumped overboard.

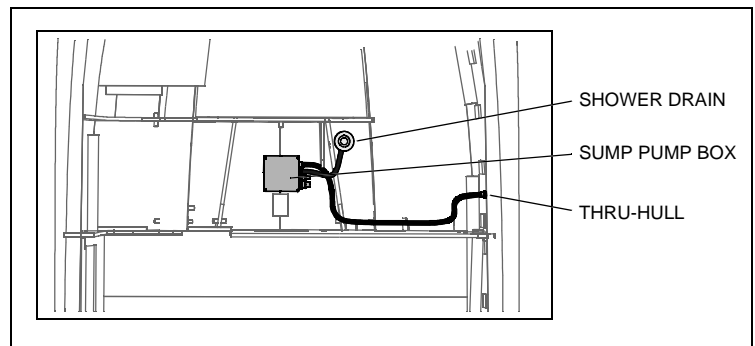

Sump Box Cleaning

Periodically clean the sump box (A), filter, and pump as follows:

1. Remove the cover screws (B) and the cover (C).
2. Remove any debris from the box and the filter.
3. Clean the sump pump as outlined in the Bilge Pump section of this manual.

Sump System Winterization

Drain the sump pump system in the months when *not* in use.

1. Disconnect and drain *all* lines to the unit.
2. Remove the screws from the mounting feet (D) and drain the system.
3. Reinstall the screws in the mounting feet and reconnect the system.

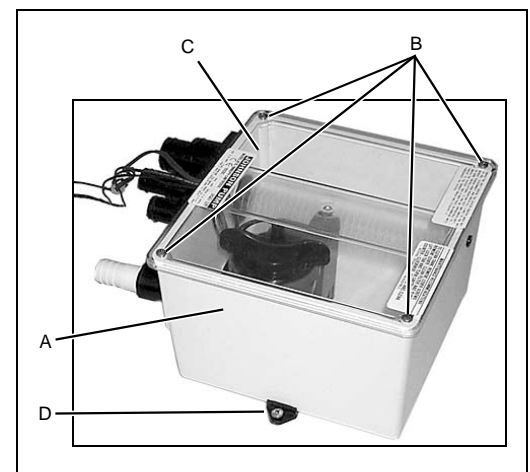

Marine Head with Holding Tank (If Equipped)

NOTICE

Check with local authorities for regulations regarding the legal use of marine head systems.

- **Before** using this system, read the marine head operation and maintenance manual.
- Look at the side of the holding tank to check the content level.
- The holding tank is plumbed to a waste fitting on the deck for dockside pump-out.
- Empty the holding tank at every opportunity.

Using The Marine Head

1. **Open** the head's seawater intake seacock.
 2. **Before** using the head, pump water into the bowl to wet the sides.
 3. After use, pump until the bowl is clean.
 4. Pump a few more times to clean the lines.
 5. If excess waste causes the water to rise in the bowl, stop pumping until the water recedes.
- **Close** the intake seacock while the boat is underway or when the system will not be used for long periods of time.

Winterizing The Marine Head

Read the marine head operation and maintenance manual for winterizing instructions.

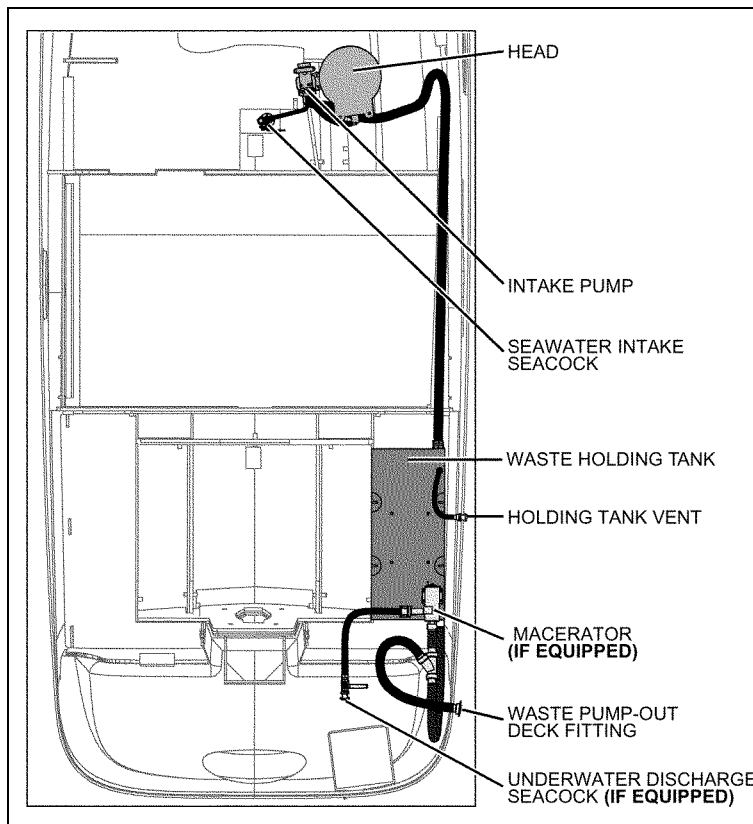

Macerator (If Equipped)

NOTICE

Check with local authorities for regulations regarding the legal use of marine head systems.

To use the macerator to pump waste directly into the water (where regulations permit):

1. **Open** the overboard discharge seacock.
2. Press both macerator switches at the same time to run the pump.
3. Stop running the macerator as soon as the waste holding tank is empty.
4. **Close** the overboard discharge seacock when you are done pumping.

Portable Toilet (If Equipped)

NOTICE

Check with local authorities for regulations regarding the legal use of marine head systems.

Read the manufacturer's operating instructions **before** using the portable toilet.

Chapter 7: Deck Equipment

Cleats and Tow Eyes

 **WARNING!**

PERSONAL INJURY and /or PRODUCT or PROPERTY DAMAGE HAZARD!
NEVER lift the boat using the cleats, bow and stern eyes.

Carefully read the section on towing in the *Cruiser & Yacht Owner's Manual* **before**:

- Towing anything behind the boat.
- Being towed by another vessel.

Windlass (If Equipped)

 **DANGER!**

PERSONAL SAFETY HAZARD!

- ***ALWAYS*** secure the anchor and other loose objects *before* getting underway.
- The anchor and other items that are *not* properly secured can come loose when the boat is moving and cause personal injury or death.

 **CAUTION**

PRODUCT DAMAGE HAZARD!

Do ***NOT*** pull the boat to the anchor using the windlass or continue to run the windlass if it has stalled or is overloaded.

- Read and follow the manufacturer's instruction manual **before** using the anchor windlass for the first time.
- The windlass can be controlled from a switch at the helm or from the deck foot switches.
- Make sure that the windlass breaker is turned ***On before*** using the anchor windlass. See the *Locations* section of this *Supplement* for the location of the windlass breaker.
- To raise the anchor, use engine power (***not*** the windlass) to move the boat to, and directly above, the anchor.
- Dislodge the anchor from the bottom by pulling it straight up with the windlass.
- Make sure the anchor is secured ***before*** getting underway.

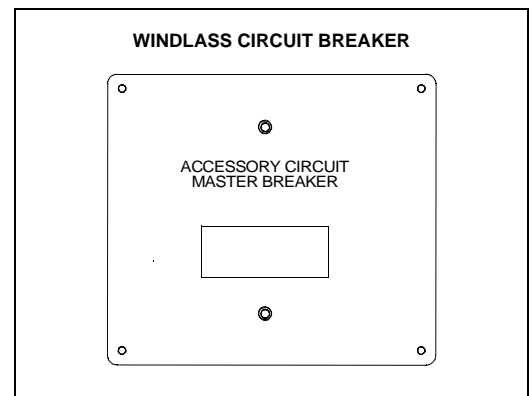

Ski-Tow Tower (If Equipped)



WARNING!

PERSONAL INJURY and /or PRODUCT or PROPERTY DAMAGE HAZARD!

Failure to follow these guidelines can result in injury or death:

- **Read *all* warning labels on ski-tow tower.**
- ***Before* each use, make sure all bolts are in place and tight.**
- ***Only* tow water skis, wakeboards, or kneeboards.**
- **Do *NOT* exceed the *maximum* tow weight of 600 pounds.**
- **Do *NOT* tow parasails, kites, tubes, rafts or other boats.**
- **Do *NOT* tow more than one person at a time.**
- **Do *NOT* climb on, sit on, stand on, jump off or dive off tower.**
- ***NEVER* allow passengers to sit behind tow rope attachment point.**
- **Use caution with skier in tow as tow rope may snap back into cockpit when released.**
- ***NEVER* allow loose tow rope ends to dangle off tower.**
- **When tower is up, watch for low obstacles such as tree limbs, bridges, or power lines.**

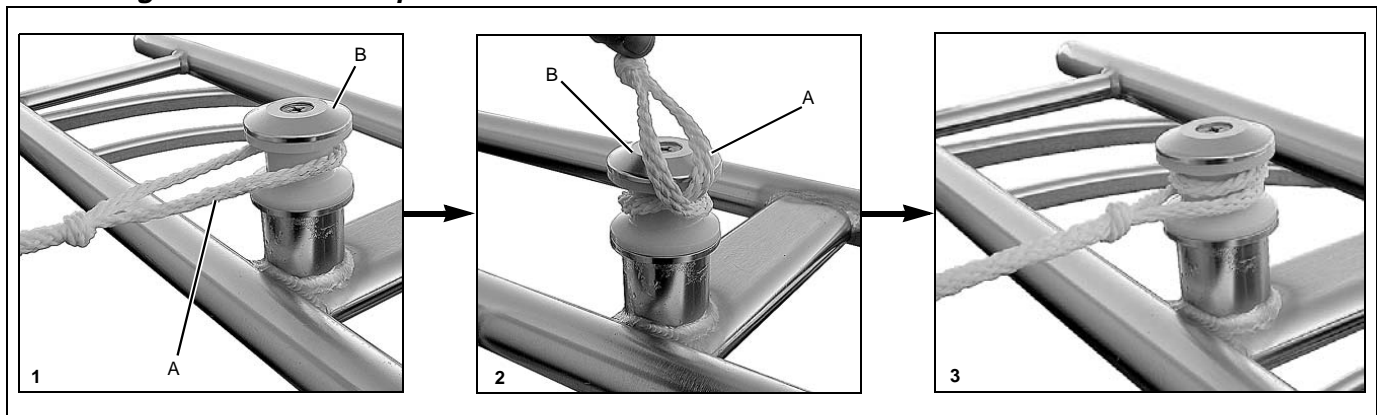
Attaching the Ski-Tow Rope



1. Place the ski-tow rope loop (A) over the ski-tow pylon (B).
2. Put a twist in the ski-tow rope loop (A) and place over the ski-tow pylon (B) again.
3. Pull ski-tow rope to tighten.

Folding the Ski-Tow Tower



WARNING!

PERSONAL INJURY and /or PRODUCT or PROPERTY DAMAGE HAZARD!

- Folding or unfolding the ski-tow tower is a two person task.
- *Before* each use of the folding ski-tow tower, make sure both lock-down bolts are tightened firmly.
- Read *all* warning labels on the ski-tow tower.

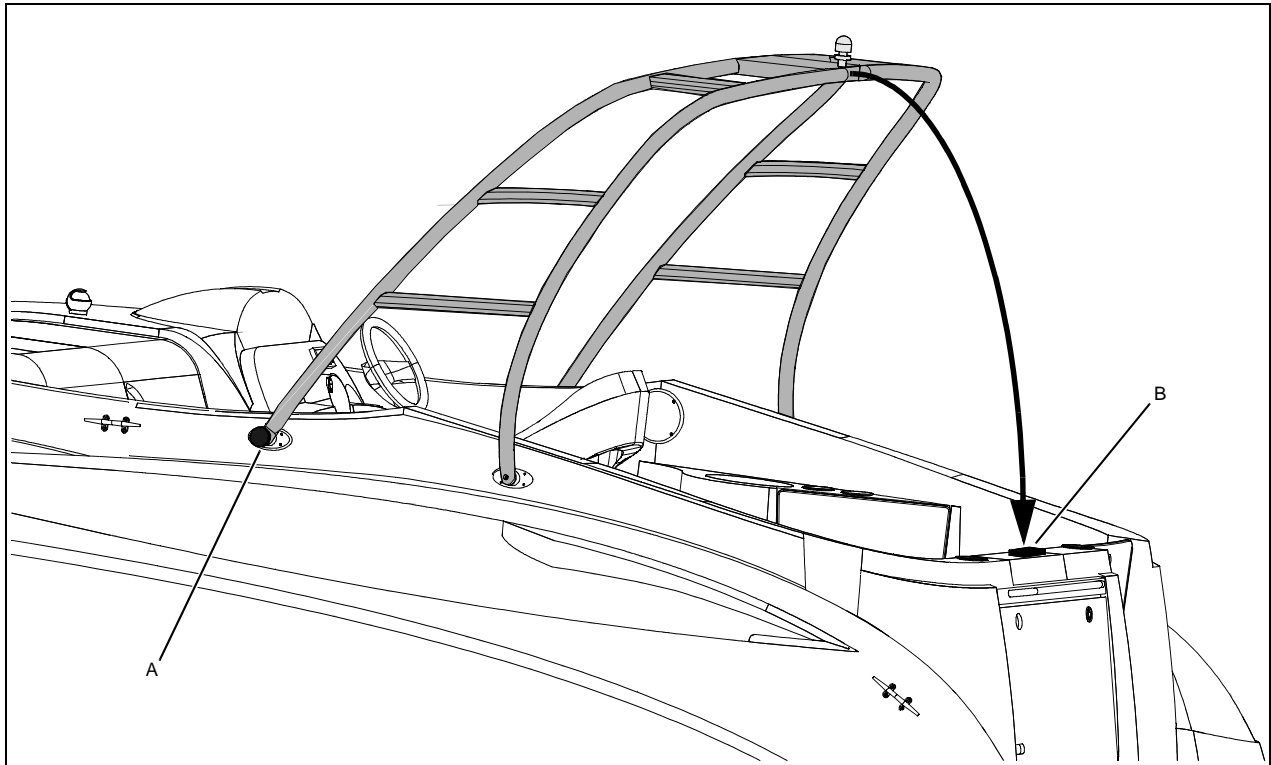

To fold the ski-tow tower into the storage position:

1. Remove the lock-down bolt (A) on each side of the tower.
2. Carefully fold the tower aft and rest the tower on the rubber bumper (B).
3. Replace the lock-down bolt (A) on each side of the tower.

To return the tower to the towing position, perform the above steps in reverse order.

Tower Care

Read the manufacturer's 'Care of Tower' card.

Canvas

⚠ CAUTION

PRODUCT or PROPERTY DAMAGE HAZARD!

Take down and securely stow ALL canvas before transporting your boat by road.

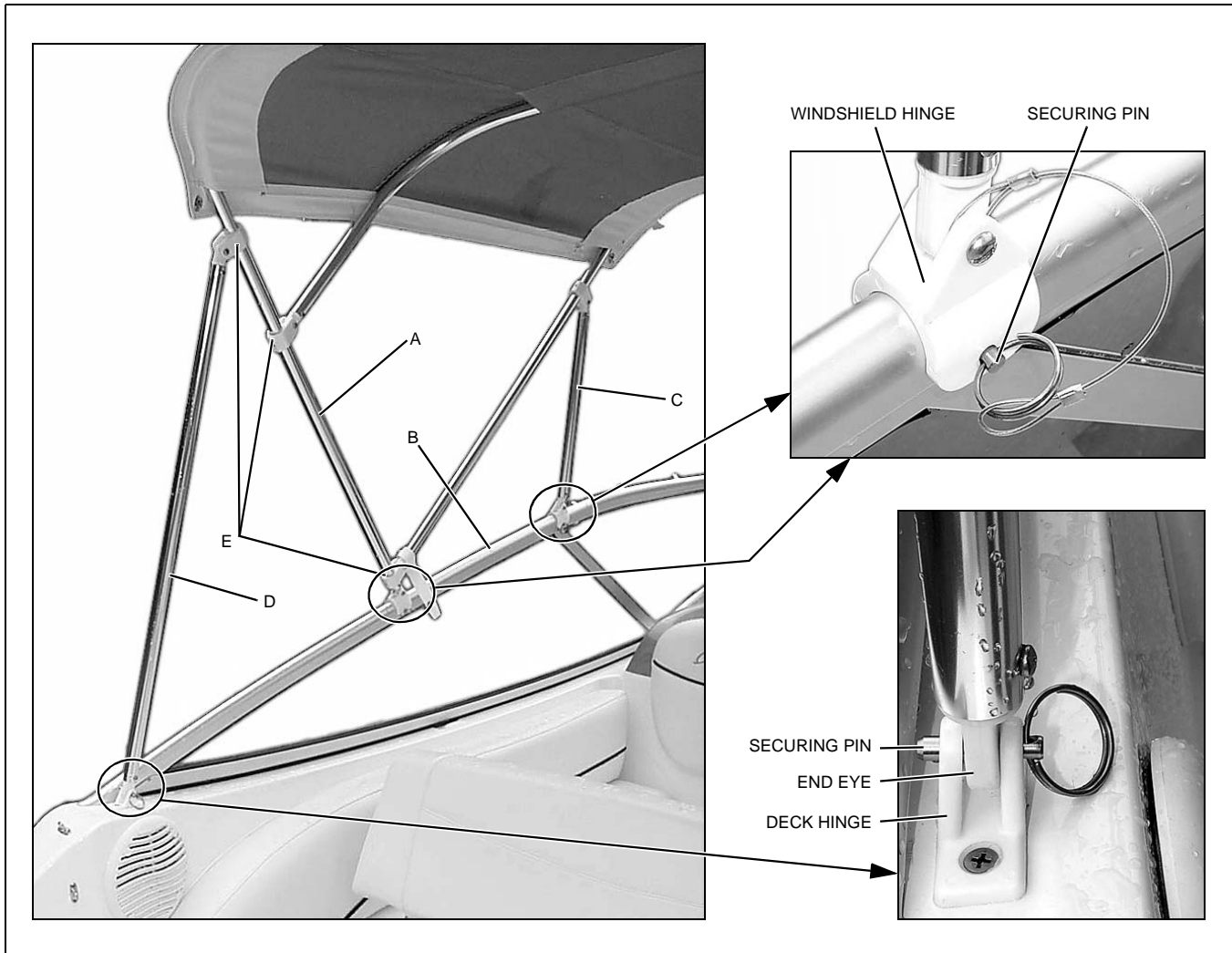

1. Slide the windshield hinges of the main bow (A) over the aft pre-drilled holes in the windshield frames (B) and insert the securing pins.
2. Unfold the canvas top and slide the windshield hinges of the forward braces (C) over the forward pre-drilled holes in the windshield frames (B) and insert the securing pins.
3. Slide the eye ends of the aft braces (D) into the deck hinges and insert the securing pins.
 - The jaw slides (E) should *not* need to be adjusted.
 - However, if you think the jaw slides need to be adjusted, obtain the measurements from your selling dealer.

Canvas Care (see also, 'Clear Vinyl Care' on next page)

- After each use, especially in saltwater, rinse the canvas with cold freshwater.
- **Before** stowing, let the canvas air dry completely.
- The canvas can be rolled or folded for stowage.

Cleaning Canvas

 CAUTION
<p>NEVER use detergents when washing the canvas. Detergents can destroy the water repellency and mildew/UV resistant finish of your canvas.</p>

Regularly clean the canvas to prevent dirt, pollen, and etc. from embedding in the fabric. Generally, it is easiest to wash the canvas while it is installed on the boat.

- Use a soft-bristled brush to remove all dust and loose dirt.
1. Hose down the canvas with freshwater.
 2. Gently wash the canvas with a solution of lukewarm water (no more than 100 F) and non-detergent soap, such as Lux or Ivory Flakes.
 3. Rinse thoroughly to remove the soap.
 4. **Before** stowing, let the canvas dry completely.

Stubborn Stains

 CAUTION
<ul style="list-style-type: none"> • Soaking in bleach solutions may remove the waterproof finish of the fabric and may also decrease the life of the polyester thread used in the canvas. • If necessary, a water repellent treatment should be re-applied to your canvas. Ask your dealer about the treatments available for your boat's canvas.

Some stubborn stains may resist normal washing and you can try the following methods. However, these methods may remove the waterproof finish of the fabric and may also decrease the life of the polyester thread used in the canvas. Reapply a water repellent treatment as necessary.

Method 1

1. Add 1/8 cup (2 oz.) of **non-chlorine** bleach to one gallon of water and mix thoroughly.
2. Thoroughly wet the canvas and then gently scrub the stained area with the weak bleach solution.
3. Rinse with cold water to remove all of the solution.

Method 2

1. Add 1/2 cup (4 oz.) of **non-chlorine** bleach and 1/2 cup (4 oz.) Ivory Flakes to one gallon of water and mix thoroughly.
2. Soak the canvas in this solution for about 20 minutes.
3. Rinse with cold water to remove all of the solution.

Clear Vinyl Care

CAUTION

- **NEVER** store the clear vinyl pieces wet, as this will cause a milky film to develop.
- **NEVER** fold or crease the clear vinyl pieces as cracking will occur.
- Clear vinyl is *not* intended for use when the boat is in storage or being moored.
- Clear vinyl *does not* hold up well against ultraviolet rays.
- Under direct sunlight conditions, do **NOT** let the clear vinyl touch the framework. The framework radiates heat and can burn the clear vinyl.

- After each use, especially in saltwater, rinse the clear vinyl with cold freshwater.
- **Before** stowing, the clear vinyl must be completely dry. Air drying is best, but you can also carefully dry the vinyl with a chamois or soft cotton cloth.
- The clear vinyl can be rolled or laid out flat for stowage.
- **Never** fold or crease the clear vinyl parts as cracking will occur.

Cleaning Clear Vinyl

Regularly clean the clear vinyl to prevent dirt, pollen, and etc. from marring the surface. Generally, it is easiest to clean the clear vinyl while it is installed on the boat.

1. Hose down the clear vinyl with freshwater.
2. Using a soft cotton cloth (**paper towels are abrasive and should never be used on clear vinyl**), gently wash the clear vinyl with soap and water.
3. Rinse thoroughly to remove the soap.
4. **Before** stowing, the clear vinyl must be completely dry. Air drying is best, but you can also carefully dry the vinyl with a chamois or soft cotton cloth.

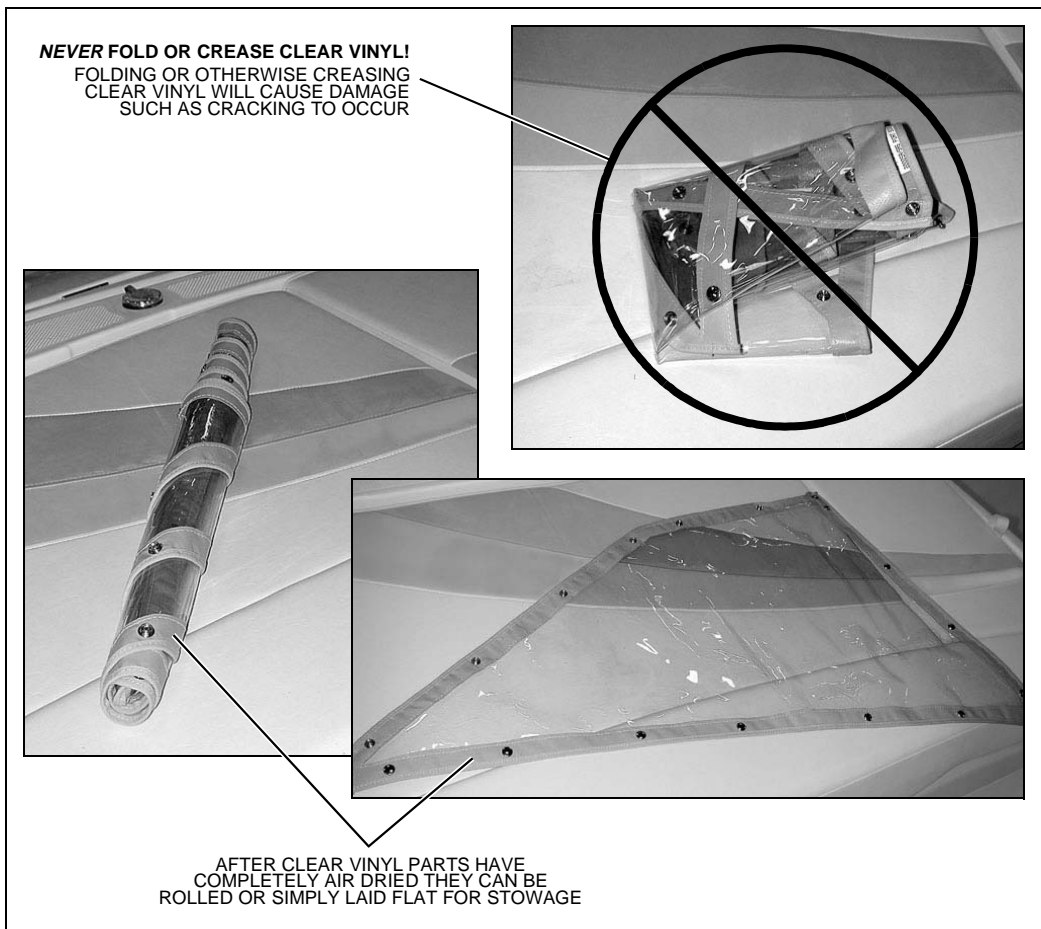

- Ask your dealer about products available to keep the clear vinyl polished and looking new.

Chapter 8: Appliances & Entertainment Systems

NOTICE

Always keep an approved ABC-type fire extinguisher in galley area.

- The separate instruction sheets or manuals for *all* appliances and entertainment systems contain detailed instructions and important safeguards.
- Read the instruction sheets and manuals *before* using your boat's appliances and entertainment systems.
- If applicable, make sure the AC breaker is turned *On* for the appliance or entertainment system you wish to use.

Audio Equipment

NOTICE

AM radio reception may be impaired anytime the engine is running.

Refrigerator (If Equipped)

Your boat may be equipped with a 110-volt AC/12-volt DC refrigerator. The refrigerator runs on 12-volt DC power unless 110-volt AC power is being supplied by shore power *and* the refrigerator's AC breaker is *On*.



Alcohol Stove (If Equipped)

⚠ DANGER!	
	<i>CARBON MONOXIDE POISONING HAZARD!</i>
	<ul style="list-style-type: none"> • The alcohol stove is a source of dangerous carbon monoxide gas (CO). • <i>Before</i> using the alcohol stove, <i>Open</i> doors and windows to make sure there is enough fresh air for ventilation.



⚠ WARNING!	
<ul style="list-style-type: none"> • Open flame cooking appliances consume oxygen, this can cause asphyxiation or death. • Maintain open ventilation. 	

⚠ WARNING!	
	<i>BURN/SCALDING and/or FIRE HAZARD!</i>
	<ul style="list-style-type: none"> • Read the stove's instruction manual <i>before</i> using. • <i>Always</i> keep an approved ABC-type fire extinguisher in galley area. • Do <i>NOT</i> use the stove while underway. • Any non-cooking devices on or near your stove during use are potential fire hazards! • Do <i>NOT</i> touch burners, grates or nearby surfaces as they may be hot even when they are dark in color. • Areas near burners and grates may become hot enough to cause burns. • During and after use, do <i>not</i> touch or let clothing or other flammable material come in contact with heated units or areas near the units (burner tops, main frame sides and back, sea rails and pot holders) until they have had sufficient time to cool.

Alcohol/Electric Stove (If Equipped)

 DANGER!	
	<i>CARBON MONOXIDE POISONING HAZARD!</i>
	<ul style="list-style-type: none"> • The alcohol stove is a source of dangerous carbon monoxide gas (CO). • <i>Before</i> using the alcohol stove, <i>Open</i> doors and windows to make sure there is enough fresh air for ventilation.

 WARNING!	
<ul style="list-style-type: none"> • Open flame cooking appliances consume oxygen, this can cause asphyxiation or death. • Maintain open ventilation. 	

 WARNING!	
	<i>BURN/SCALDING and/or FIRE HAZARD!</i>
	<ul style="list-style-type: none"> • Read the stove's instruction manual <i>before</i> using. • <i>Always</i> keep an approved ABC-type fire extinguisher in the galley area. • Do <i>NOT</i> use the stove while underway. • Any non-cooking devices on or near your stove during use are potential fire hazards! • Do <i>NOT</i> touch the burners, grates or nearby surfaces as they may be hot even when they are dark in color. • Areas near the burners and grates may become hot enough to cause burns. • During and after use, do <i>not</i> touch or let clothing or other flammable material come in contact with the heated units or the areas near the units (burner tops, main frame sides and back, sea rails and pot holders) until they have had sufficient time to cool.

 CAUTION	
<i>PRODUCT DAMAGE HAZARD!</i>	
To prevent overheating which can destroy the electric burner elements, <i>NEVER</i> attempt to use both alcohol and electric burners at the same time.	

Chapter 9: Convertible Seats, Beds, & Tables

Dinette to V-berth Sleeping Area

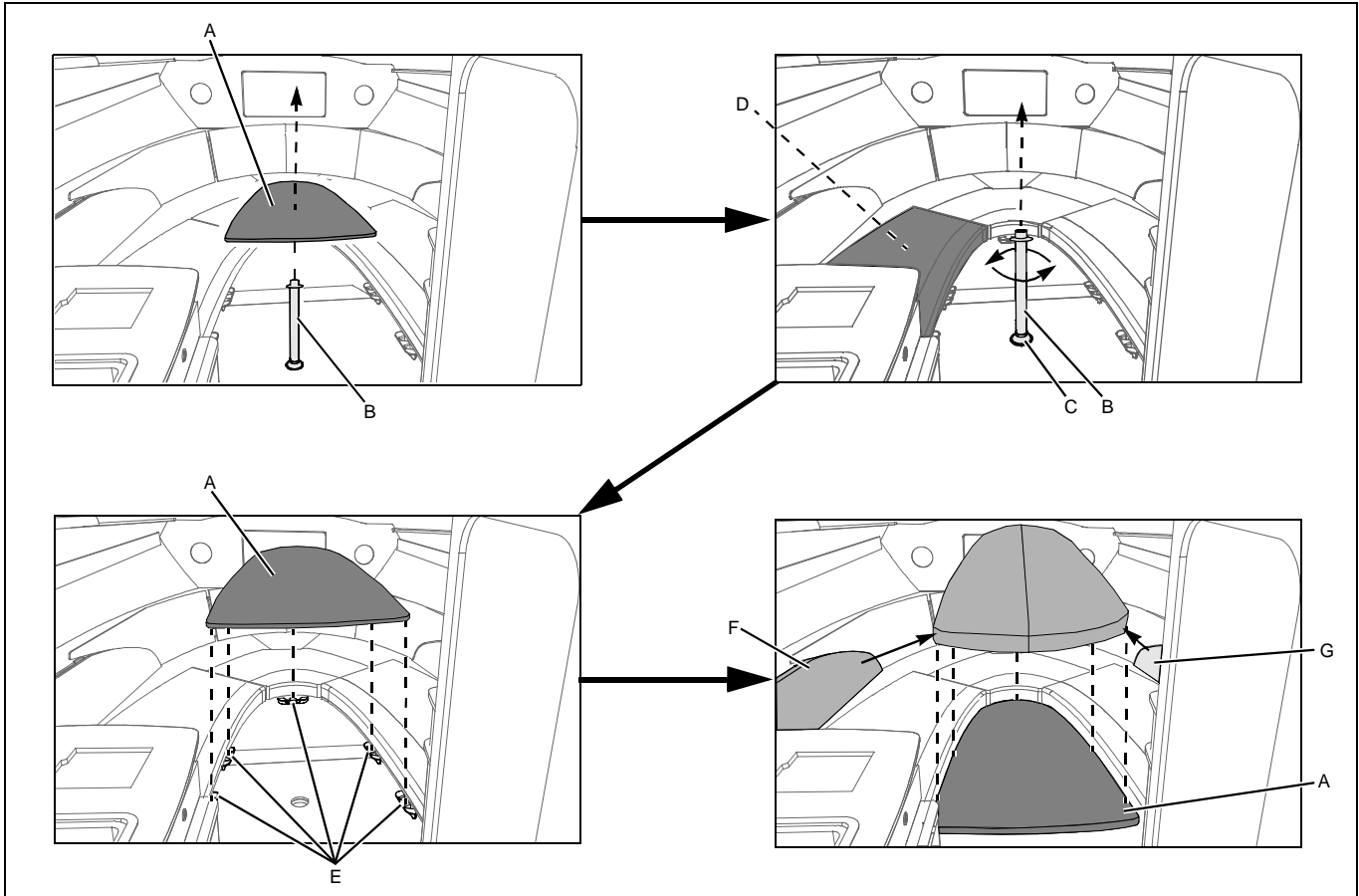

1. Pull up on the dinette table top (A) to remove it from the table post (B).
2. Unscrew the table post (B) counterclockwise and remove it from the post base (C).
3. Stow the table post (B) on the clips located in the stowage space (D) under the port seat cushion.
4. Place the dinette table top (A) on top of the support brackets (E).
5. Unsnap and remove the port and starboard, aft seat back cushions (F & G).
6. Place both of the cushions (F & G) on top of the dinette table top (A).

Chapter 10: Lights

Care and Maintenance

All of the lights installed on your boat are of top quality, but you should be aware that failure may periodically occur for a variety of reasons:

1. There may be a blown fuse - *replace the fuse.*
2. The bulb may be burned out - *carry spare bulbs for replacement.*
3. A wire may be damaged or may have come loose - *repair as required.*
4. The bulb base may be corroded - *clean the base and coat it with non-conductive electrical lubricant.*

Interior & Exterior Lights

 CAUTION!
<ul style="list-style-type: none"> • Be conservative in the use of battery power. • Prolonged use of cabin interior lights (overnight) <i>will</i> result in a drained battery.

- The lights are powered by the boat's 12-volt DC system.
- The battery switch *must* be turned *On* for the lights to work.

Navigation Lights

 CAUTION!
<p>Avoid the storage of gear where it would block navigation lights from view.</p>

Read the navigation light section of the *Cruiser & Yacht Owner's Manual*.

Spotlight (If Equipped)

Read the spotlight operating instructions *before* using the spotlight.

Chapter 11: Heating & Air Conditioning System

Air Conditioning System (If Equipped)

⚠ **DANGER!**



CARBON MONOXIDE POISONING HAZARD!

Dangerous carbon monoxide gas (CO) can be brought into the boat through the air conditioning system.

⚠ **CAUTION**

SYSTEM DAMAGE HAZARD!

The air conditioning system's seawater intake seacock *must* be *Opened before turning On* the air conditioner and *must stay Open* during use.

- Read the air conditioner manual *before* using the air conditioning system.
- *Before* using the air conditioning system, make sure the breakers on the AC main distribution panel are turned *On* and that the system's seawater intake seacock is *Open*.
- The seacock *must* remain *Open* while the air conditioner is in use.
- Check the seawater strainer for debris *before* each use of the air conditioning system.
- If the strainer needs to be cleaned out; follow the directions in the *Seawater Systems* section of this *Supplement*.

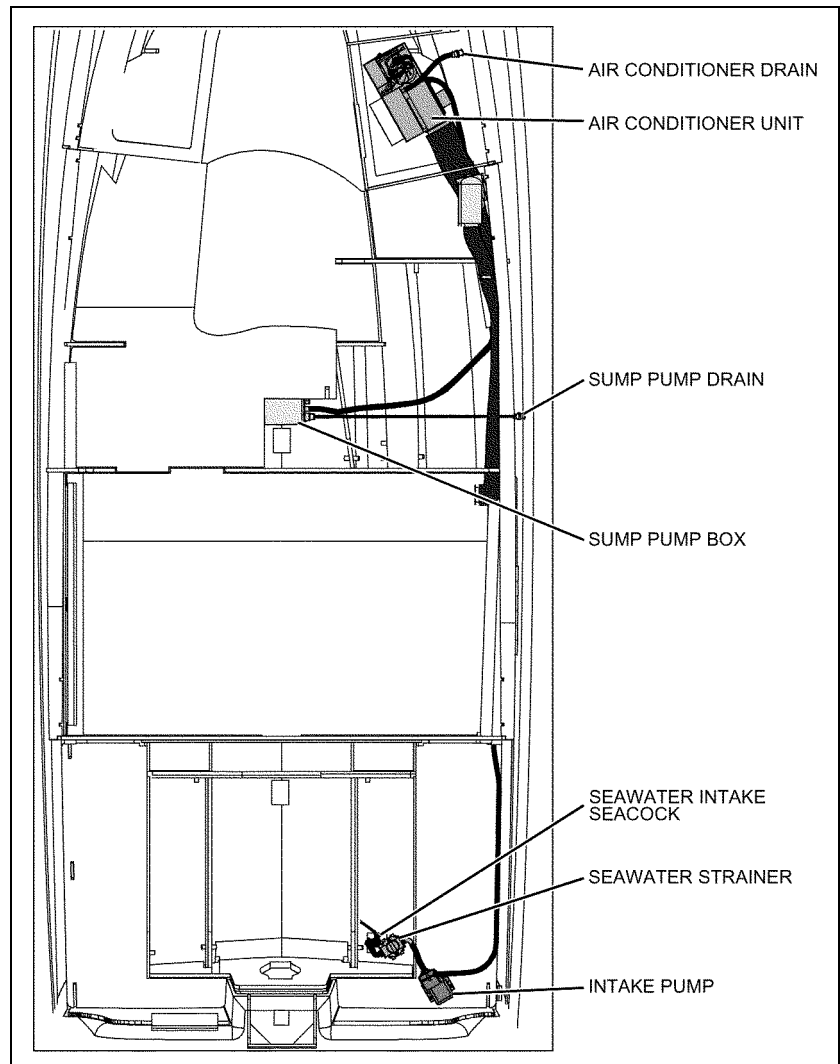

Chapter 12: Electrical System



DANGER!









EXTREME FIRE, SHOCK & EXPLOSION HAZARD!

- To minimize the risks of fire and explosion, *NEVER* install knife switches or other arcing devices in the fuel compartments.
- *NEVER* substitute automotive parts for marine parts. Electrical, ignition and fuel system parts were designed and manufactured to comply with rules and regulations that minimize risks of fire and explosion.
- Do *NOT* modify the electrical systems or relevant drawings.
- Have qualified personnel install batteries and/or perform electrical system maintenance.
- Make sure that *all* battery switches are turned *Off before* performing any work in the engine spaces.



WARNING!

FIRE & EXPLOSION HAZARD!

- Fuel fumes are heavier than air and *will* collect in the bilge areas where they can be accidentally ignited.
- Visually and by smell (sniff test), check the engine and fuel compartments for fumes or accumulation of fuel.
- *ALWAYS* run the bilge blower(s) for at least four minutes prior to engine starting, electrical system maintenance or activation of electrical devices.
- *NEVER* expose the batteries to open flame or sparks, and *NEVER* smoke anywhere near the batteries.

CAUTION



SHOCK & ELECTRICAL SYSTEM DAMAGE HAZARD!

When the engine is running, *NEVER* turn *Off* the battery switch or disconnect the battery cables. Doing either could cause damage to your boat's engine and/or electrical system.

NOTICE

Electrical connections are prone to corrosion. To reduce corrosion caused electrical problems, keep *all* electrical connections clean and apply a spray-on protectant that is designed to protect connections from corrosion.

12-Volt DC System

Battery

The battery supplies electricity for lights, 12-volt accessories, and engine starting. The Electrical section of Chapter 8, in the *Cruiser & Yacht Owner's Manual*, provides battery, care and maintenance instructions.

Battery Switch (If Equipped With One Battery)

⚠ CAUTION

⚡ SHOCK & ELECTRICAL SYSTEM DAMAGE HAZARD!

When the engine is running, *NEVER* turn *Off* the battery switch or disconnect the battery cables. Doing either could cause damage to your boat's engine and/or electrical system components.

NOTICE

Make sure your selling dealer fully explains how to use the battery switch.

- "Stand-by Loads", such as the automatic bilge pump, and the stereo memory, are *not* affected by the battery switch. Stand-by loads bypass the battery switch and are wired directly to the battery.
- Turn the battery switch to the *Off* position whenever the boat will be unoccupied for long periods of time.

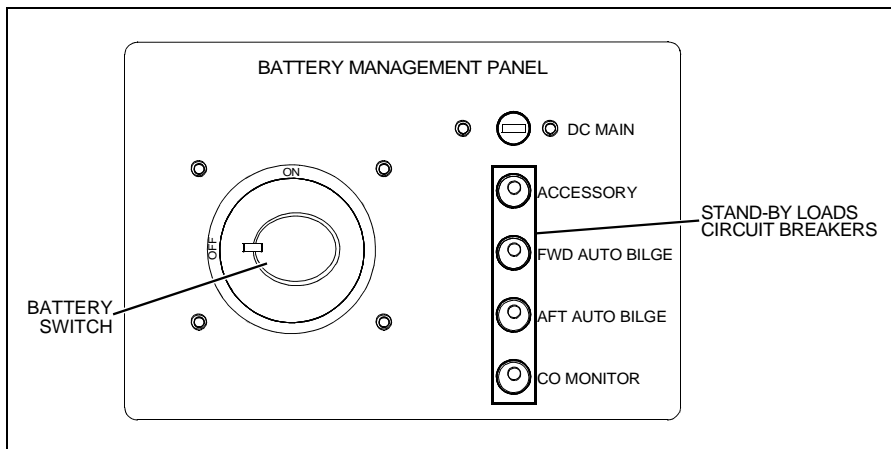

Battery Switch (If Equipped With Two Batteries)

⚠ CAUTION

SHOCK & ELECTRICAL SYSTEM DAMAGE HAZARD!

When the engine is running, *NEVER* turn *Off* the battery switch or disconnect the battery cables. Doing either could cause damage to your boat's engine and/or electrical system components.

- "Stand-by loads", such as the automatic bilge pumps, and the stereo memory, are *not* affected by the battery switch. Stand-by loads bypass the battery switch and are wired directly to the batteries.
- Turn the battery switch to the *Off* position whenever the boat will be unoccupied for long periods of time.

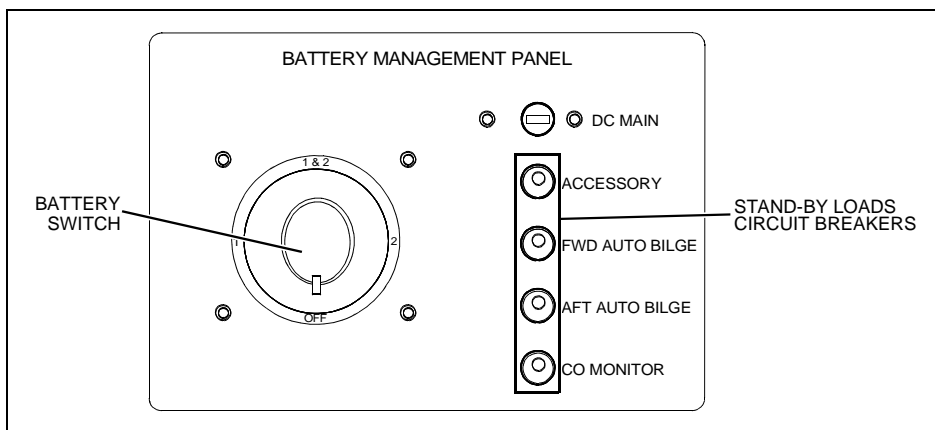

Battery Switch Positions

NOTICE

Since your boat's batteries were installed by your dealer, the battery switch positions listed below may vary. Make sure your selling dealer fully explains how to use the battery switches.

BATTERY SWITCH POSITIONS	ENGINE STARTING	ACCESSORIES & LIGHTS	ENGINE ALTERNATOR	BATTERY CHARGER
POSITION "1"	Battery <u>1</u> Provides Start-ing Power	Battery <u>1</u> Provides Power for Accessories and Lights	Charges Battery <u>1</u>	Charges BOTH Batteries
POSITION "2"	Battery <u>2</u> Provides Start-ing Power	Battery <u>2</u> Provides Power for Accessories and Lights	Charges Battery <u>2</u>	Charges BOTH Batteries
"BOTH" or "1 & 2" POSITION	BOTH Batteries Provide Start-ing Power	BOTH Batteries Provide Power for Accessories and Lights (not advised unless engine is running)	Charges BOTH Batteries	Charges BOTH Batteries

Fuses and Circuit Breakers

- Fuses for the accessory items are on the fuse blocks.
- Some equipment may have secondary fuse protection at the unit, or at the battery.
- The DC circuit breakers for the stand-by loads, and the DC main circuit breaker for the engine and main accessory power, are located on the battery switch panel.
- See the *Locations* section of this *Supplement* for the location of the fuse blocks and circuit breakers.

12-Volt Accessory Outlet

 CAUTION
<p>Do <i>NOT</i> use the 12-volt accessory outlet with a cigarette or cigar lighter. High temperatures may melt the outlet.</p>

- Your boat is equipped with one or more 12-volt accessory outlets.
- The outlet(s) can be used with any 12-volt device which draws 15-amps or less.
- Each 12-volt accessory outlet is protected by a 15-amp fuse on the DC breaker panel.

Alternator

The engine alternator will keep the battery properly charged when running at cruising speeds.

Battery Charger (If Equipped)

 CAUTION
<p>ENGINE & ELECTRICAL SYSTEM DAMAGE HAZARD!</p> <p>NEVER run the boat's engine and the battery charger at the same time.</p>

 CAUTION
<ul style="list-style-type: none"> • The battery charging systems (alternator and battery charger) installed on your boat are designed to charge conventional lead-acid batteries. • Before installing gel-cell or other new technology batteries, consult with the battery manufacturer about charging system requirements.

- **Before** using the battery charger, read *all* instructions and warnings: (1) on the battery charger, (2) on the battery, and (3) in the battery charger manual.
- The battery charger will charge the boat's battery (or batteries) whenever the boat is plugged into 110V/60Hz shore power *and* the "BATTERY CHARGER" AC circuit breaker is *On*.
- The battery switch can be in any position during charging.
- You may use DC powered electrical systems, such as the lights and stereo when charging the batteries, but there will be a corresponding drop in charger performance.

110-Volt AC System (If Equipped)



CAUTION

WATER HEATER DAMAGE HAZARD!

- Do **NOT** turn *On* the water heater breaker on the 110-Volt AC panel until the water heater tank is *completely* filled with water.
- The tank is full if water flows from the tap when the hot water is turned *On* in the galley.
- Even momentary operation in a dry tank *will* damage the heating elements.
- Warranty replacements will **NOT** be made on elements damaged in this manner.

NOTICE

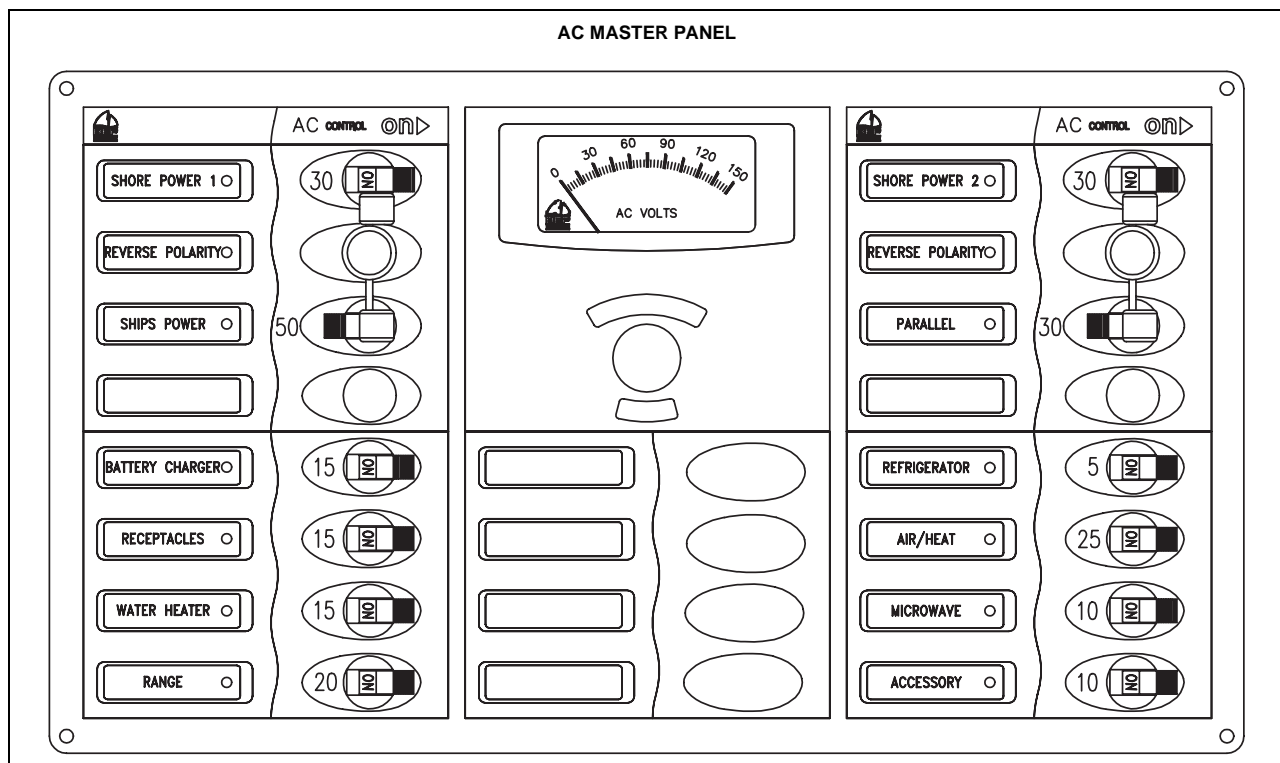
- When using shore power, the simultaneous use of several AC components can result in an overloaded circuit.
- It may be necessary to turn *Off* one or more accessories in order to use another accessory.



- To gain a basic understanding of your boat's 110-Volt AC system, read the information provided in the handbook, "A Boater's Guide To AC Electrical Systems." If a copy of this handbook was not included in your owner's packet, call 360-435-8957 and one will be mailed to you.
- The AC system can be energized by shore power.
- The master circuit breakers, located on the AC panel, provide power source selections to AC powered accessories.
- Individual breakers *must* be turned *On* to supply power to the accessories you wish to use.
- The AC panel may contain inactive circuit breakers for accessories that are not available for this model boat.

Shore Power

DANGER!



FIRE, EXPLOSION & SHOCK HAZARD!

- Do **NOT** alter the shore power connectors and use *only* compatible connectors.
- *Before* plugging in or unplugging the shore power cord to your boat, make sure *all* breakers and switches on the AC master panel are turned *Off*.
- To prevent shock or injury from an accidental dropping of the 'hot' cord into the water; **ALWAYS** plug the shore power cord into the boat inlet first; then into the dockside outlet. When unplugging from shore power, **ALWAYS** unplug the shore power cord from the dockside outlet first.
- **NEVER** leave the shore power cord *only* plugged into the dockside outlet.
- Only use shore power cords approved for marine use. **NEVER** use ordinary indoor or outdoor extension cords.

WARNING!



SHOCK & ELECTRICAL SYSTEM DAMAGE HAZARD!

- Monitor the polarity indicator lights *every time* you connect to shore power.
- If a reversed polarity light turns *On* when you are connecting to shore power, do **NOT** turn *On* the main breaker switches.
- Instead, *immediately* unplug the shore power cord (*always* from the dockside outlet first) and alert marina management.

WARNING!

SHOCK & ELECTRICAL SYSTEM DAMAGE HAZARD!

- *Before* each use, check the shore power cord for defects or damage.
- **NEVER** use a damaged or faulty cord since the danger of fire and electrical shock exists.
- Do **NOT** pinch the shore power cord in doors or hatches, or coil the shore power cord too tightly since these situations can generate enough heat to result in a fire.
- If a shore power cord is dropped into the water, *completely* dry the blades and contact slots *before* using.

CAUTION

ELECTRICAL SYSTEM DAMAGE HAZARD!

- **NEVER** connect to dockside power outside of North America unless you have the international electrical conversion option.
- Using several AC components at the same time can result in an overloaded circuit. You may have to turn *Off* one or more appliances in order to use another appliance.
- Use double insulated or three-wire protected electrical appliances whenever possible.

- The single shore power 110-volt/60-hertz, AC system (if equipped) features one, 110-volt/30-amp, shore power receptacle.
- If your boat is equipped with an air conditioning system, a second (dual) 110-volt/30-amp inlet has been installed.
- Dual shore power inlets are labeled “LINE 1” and “LINE 2”, which corresponds to the “SHORE POWER 1” and “SHORE POWER 2” master breakers on the dual shore power AC panel.
- Dual shore power systems are designed so that each line is independent of the other except when the parallel switch is used.

Connecting To Shore Power

WARNING!

SHOCK & ELECTRICAL SYSTEM DAMAGE HAZARD!

- Monitor the polarity indicator lights *every time* you connect to shore power.
- If a reversed polarity light turns *On* when you are connecting to shore power, do *NOT* turn *On* the main breaker switches.
- Instead, *immediately* unplug the shore power cord (*always* from the dockside outlet first) and alert marina management.

1. Review *all* hazard information at the beginning of this section, *Shore Power*.
2. Turn *Off* the shore power master circuit breaker(s) and *all* switches and breakers on the AC master panel.
3. Attach the shore power cord(s) to the boat inlet(s) first, then to the dockside outlet(s).
4. Turn *on* the shore power master circuit breaker(s).
5. Turn *on* "SHORE POWER 1" and "SHORE POWER 2" (if equipped) master breaker(s) on the AC master panel.
6. On the AC master panel turn *on* the individual component breakers as needed.

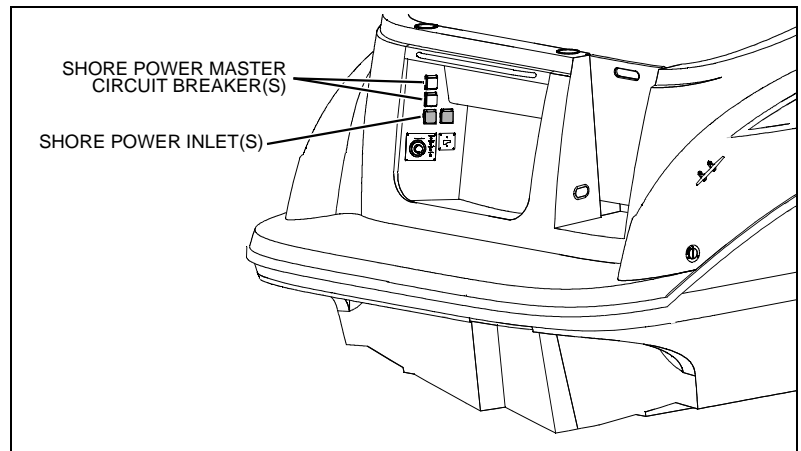

Parallel Switch (If Equipped with Dual Shore Power)

NOTICE

- When using the Parallel Switch do *NOT* exceed 30 total amps.
- The amperage of each component breaker is shown on the breaker itself.
- The voltage on each line can be read by viewing the voltmeter on the Shore Power AC panel.

When only one dockside outlet is available, you can use the Parallel Switch to provide power to both lines.

1. Connect to shore power as described above.
2. Switch the Parallel Switch *On* instead of the “SHORE POWER 2” master breaker.
3. Turn *On* the individual component breakers as required.

Electrical Routings

12-Volt DC Deck Electrical Harnesses

NOTE: VIEW IS OF UNDER SIDE OF DECK.

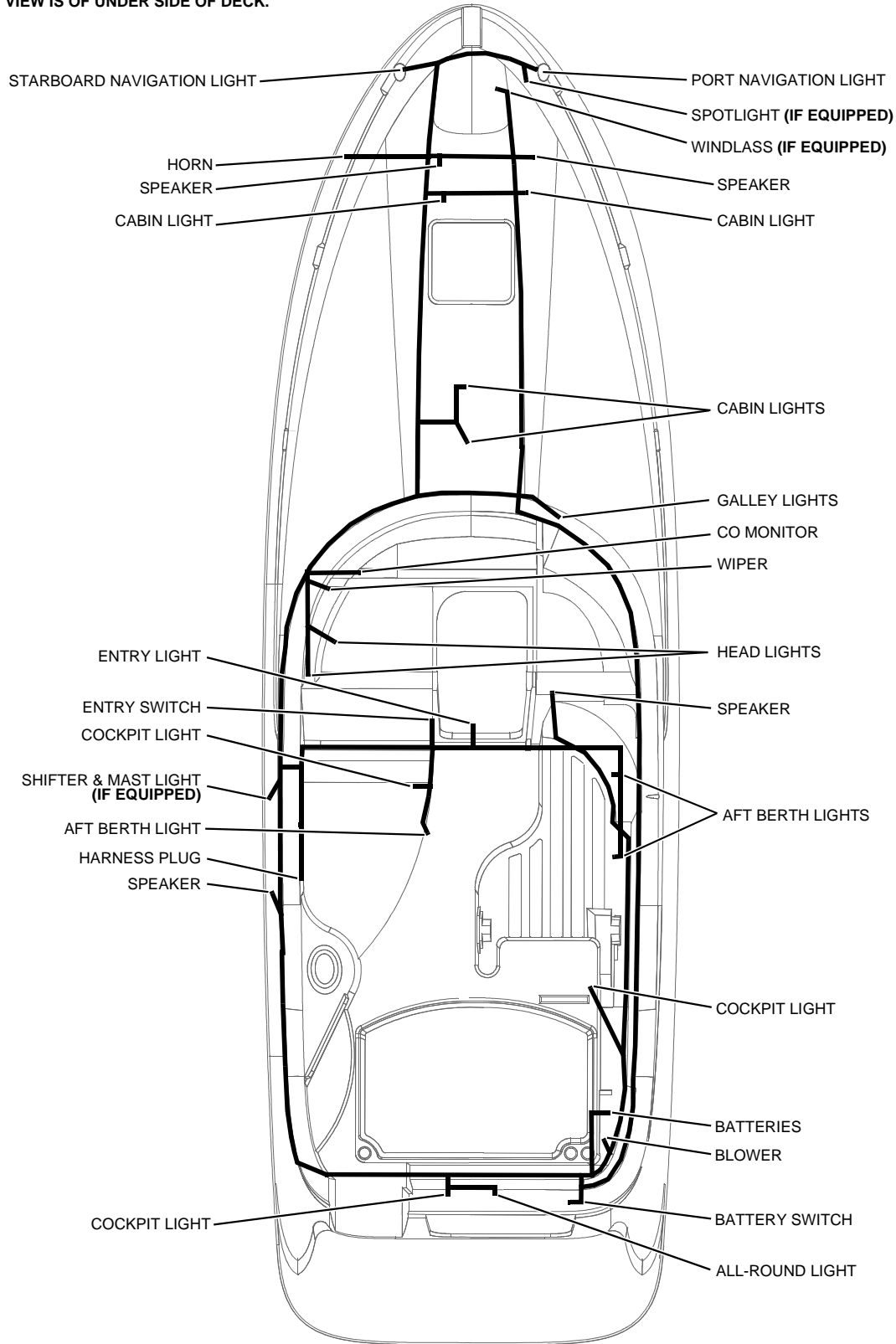

12-Volt DC Hull Electrical Harnesses

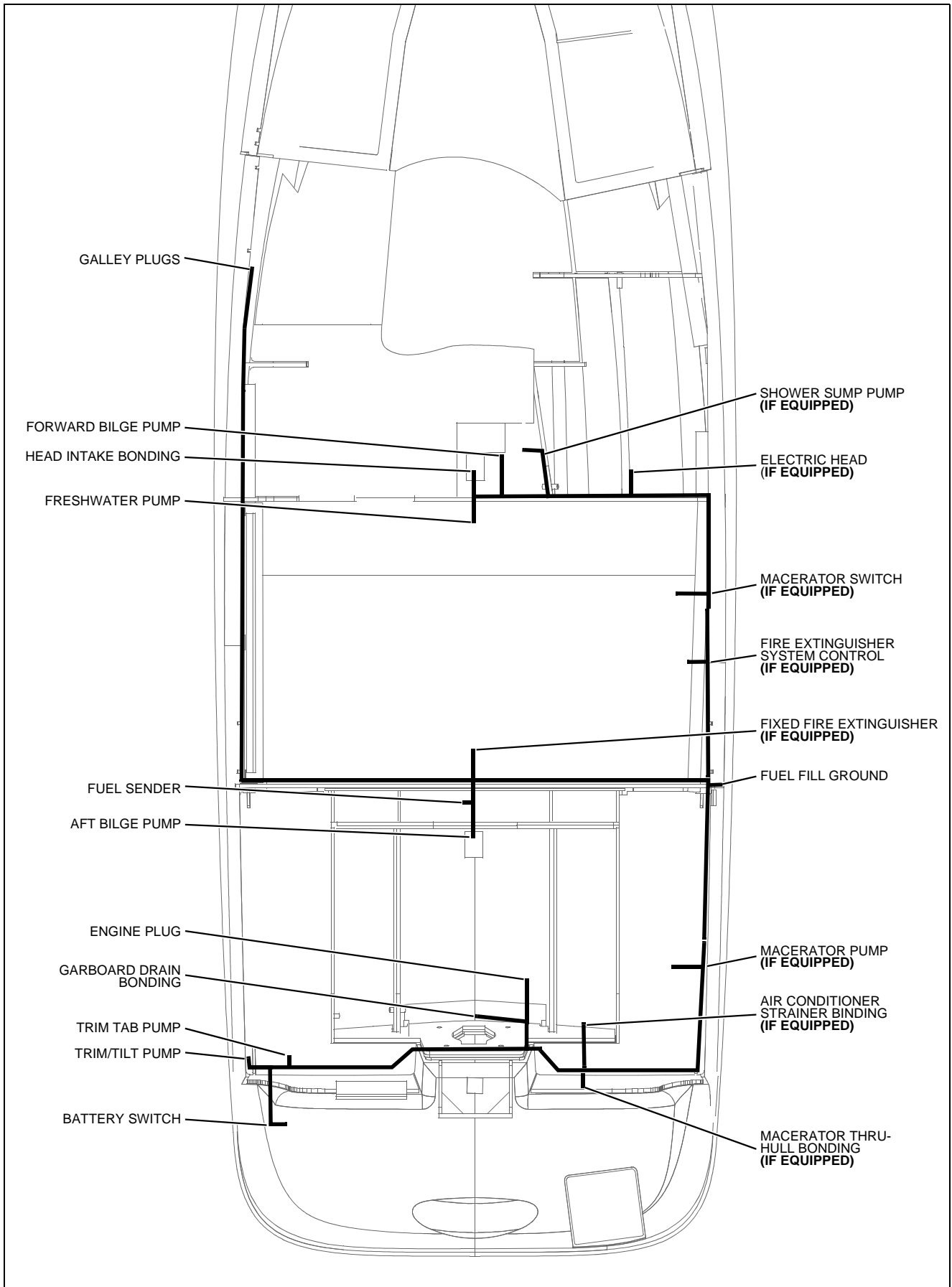

110-Volt AC Hull Electrical Harnesses (If Equipped)

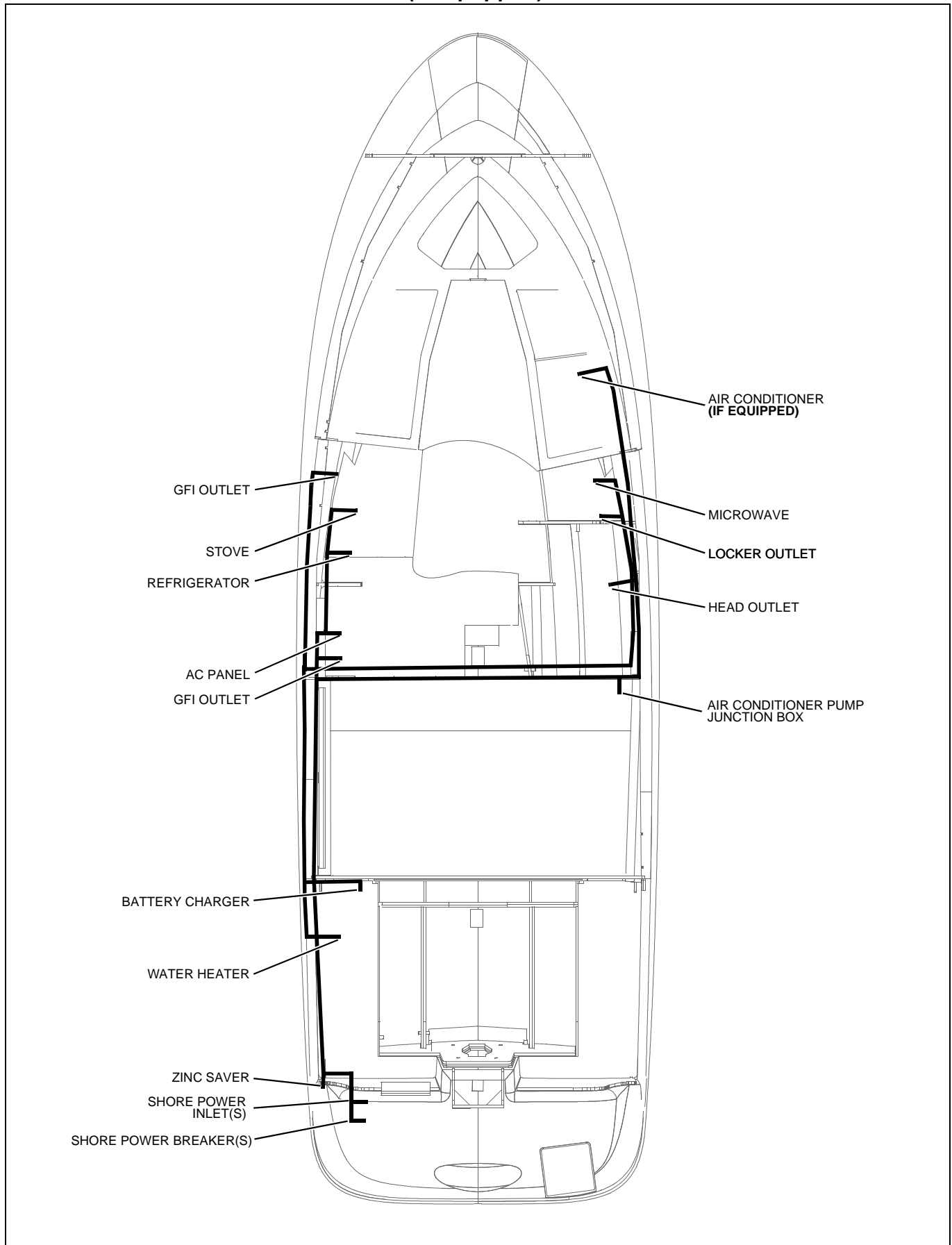

Wiring Diagrams

12-Volt DC Electrical System

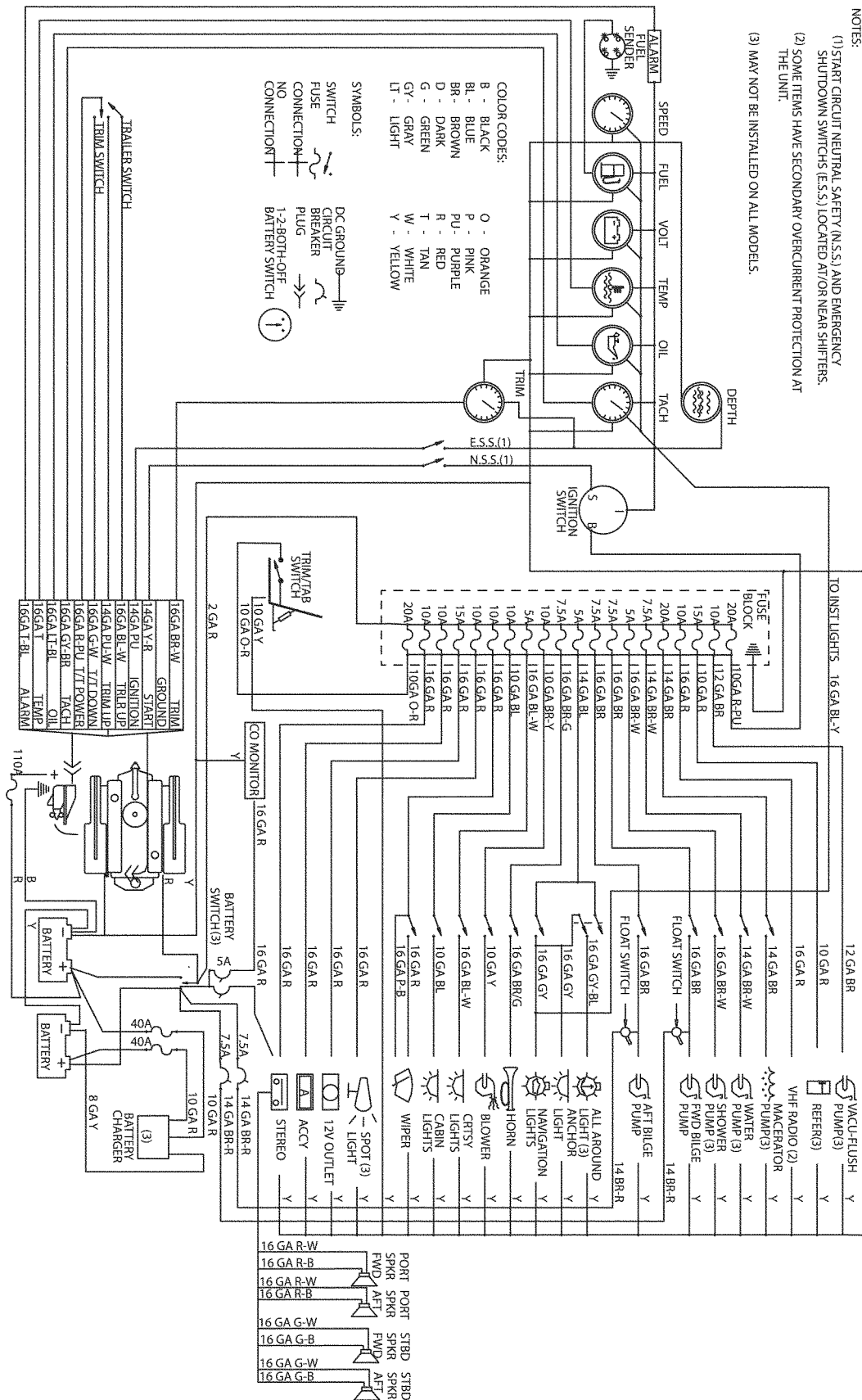

Single Shore Power (If Equipped)

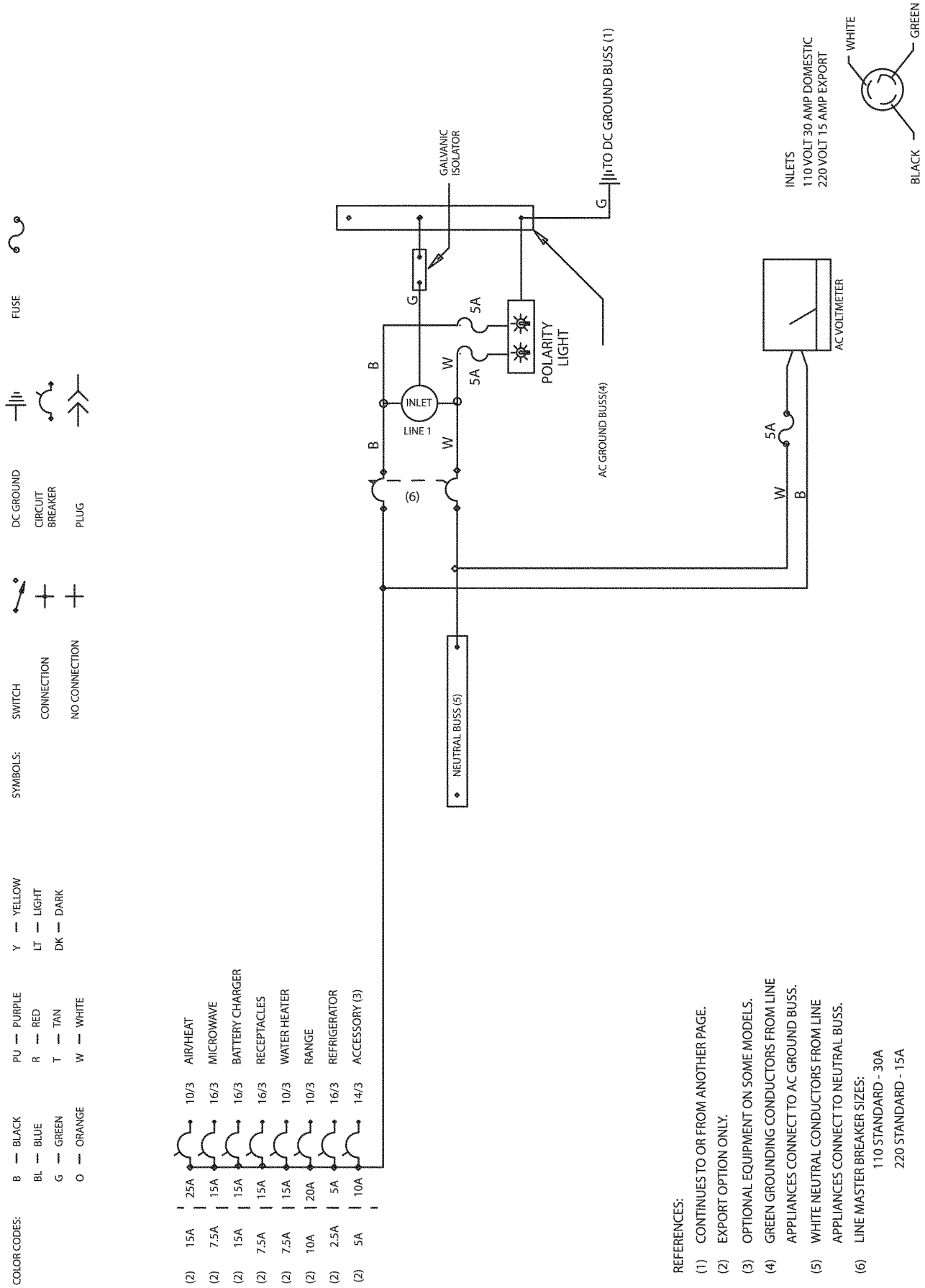

Dual Shore Power (If Equipped)

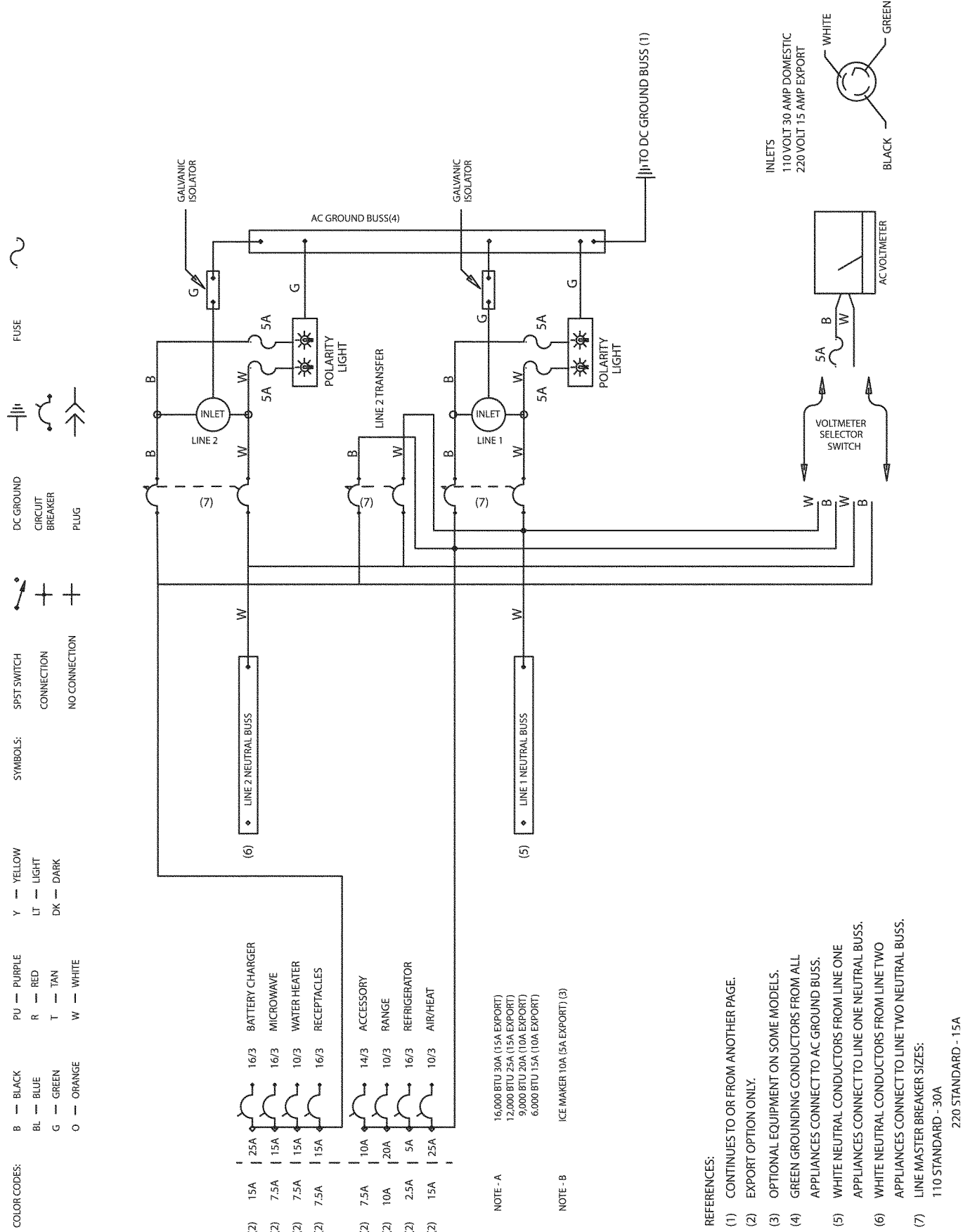

Windlass Wiring Diagram (If Equipped)

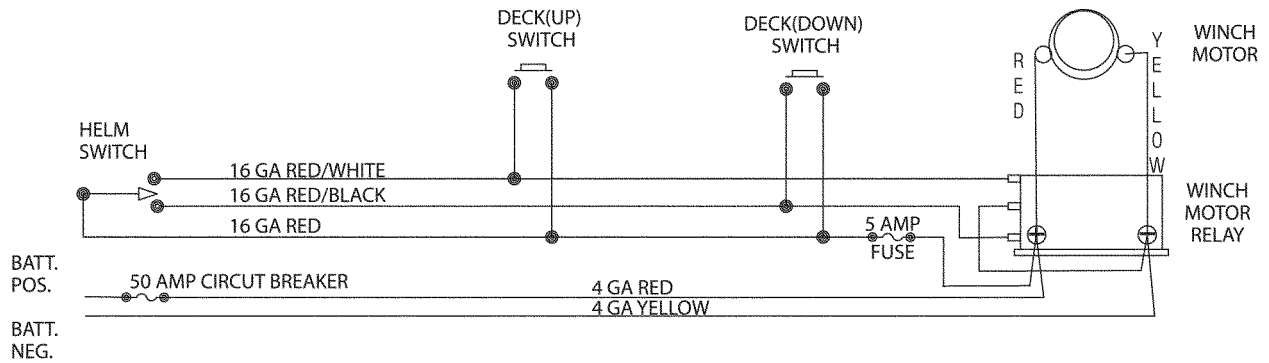

Fire Suppression System Wiring Diagram (If Equipped)

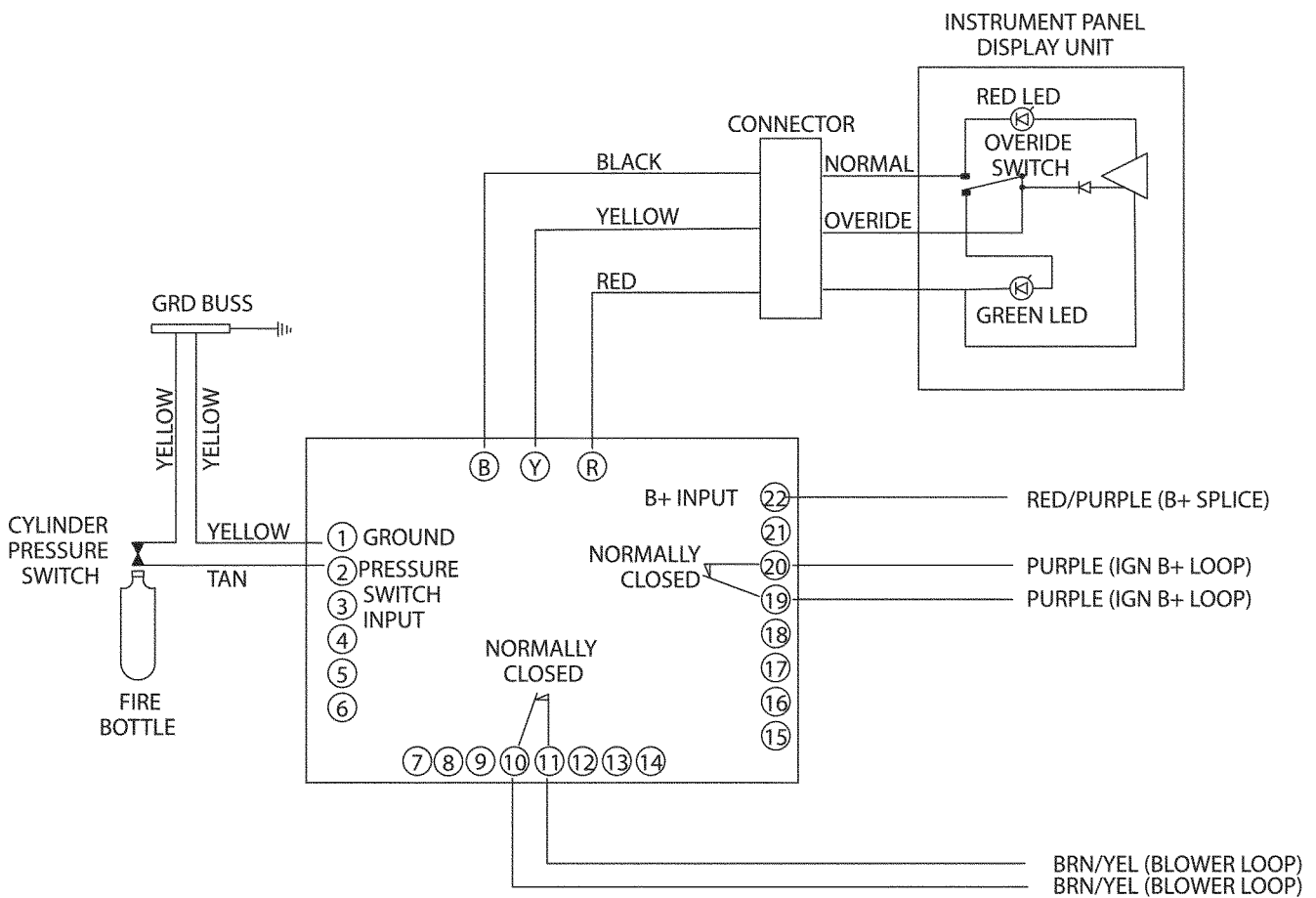

Important Records

Selling Dealer

Name Of Dealership

Address

Phone/FAX/E-mail

Sales Manager

Service Manager

Engine

Manufacturer

Model Name/Number

Engine Serial Number

Oil Type/SAE

Quarts per Engine

Filter Type

Propeller

Manufacturer

Pitch

Model Number

Key Numbers

Ignition

Other

Electronics

Manufacturer

Model Name/Number

Serial Number

Manufacturer

Model Name/Number

Serial Number

Manufacturer

Model Name/Number

Serial Number

Float Plan

Before going boating, fill out a copy of this float plan (or similar) and leave it with a *reliable* person whom you can depend on to contact the Coast Guard or other rescue organization, if you do not return as scheduled.

Description of Boat

Registration/Documentation Number		
Length	Make	Type
Hull Color		Trim Color
Fuel Capacity	Engine Type	Number of Engines
Distinguishing Features		
Distinguishing Features		

Persons on Board

Full Name		
Age	Health	Phone Number
Full Name		
Age	Health	Phone Number
Full Name		
Age	Health	Phone Number
Full Name		
Age	Health	Phone Number
Full Name		
Age	Health	Phone Number
Full Name		
Age	Health	Phone Number

Operator of Boat

Full Name		
Male or Female	Age	Health
Address		
Address		
Phone/FAX/E-mail		
Operator's Experience		

Survival Equipment

Marine Radio (Yes/No)	Type	Frequencies
Number of PFDs	Flares (Yes/No)	Mirror (yes or no)
Smoke Signals (Yes/No)	Flashlight (Yes/No)	Food (Yes/No)
Water (Yes/No)	Anchor (Yes/No)	Raft/Dinghy (Yes/No)
Paddles (Yes/No)	EPIRB (Yes/No)	Other
Other	Other	Other

Vehicle Description

Make	Model
Color	License Number
Where is the Vehicle Parked?	

Trip Expectations

Departing From	
Departure Date	Departure Time
Stopover 1	
Arrive No Later Than: Date	Arrive No Later Than: Time
Stopover 2	
Arrive No Later Than: Date	Arrive No Later Than: Time
Stopover 3	
Arrive No Later Than: Date	Arrive No Later Than: Time
Stopover 4	
Arrive No Later Than: Date	Arrive No Later Than: Time
Stopover 5	
Arrive No Later Than: Date	Arrive No Later Than: Time
Stopover 6	
Arrive No Later Than: Date	Arrive No Later Than: Time
Final Destination Port (If Different Than Home Port)	
Arrive No Later Than: Date	Arrive No Later Than: Time
Coast Guard Phone Number	
Local Authority Phone Number	

If not returned by the date and time listed above, call the Coast Guard or other local authority.

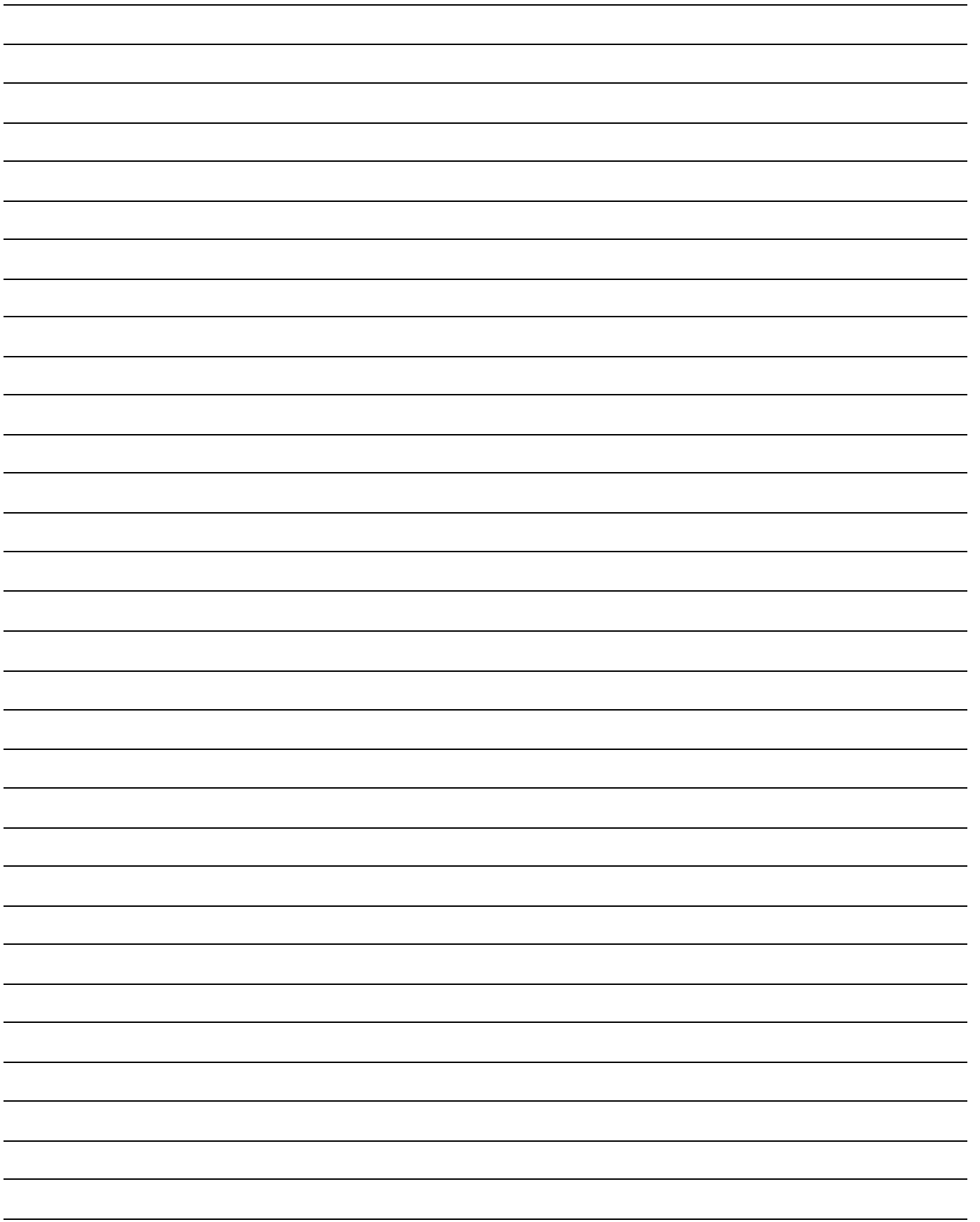

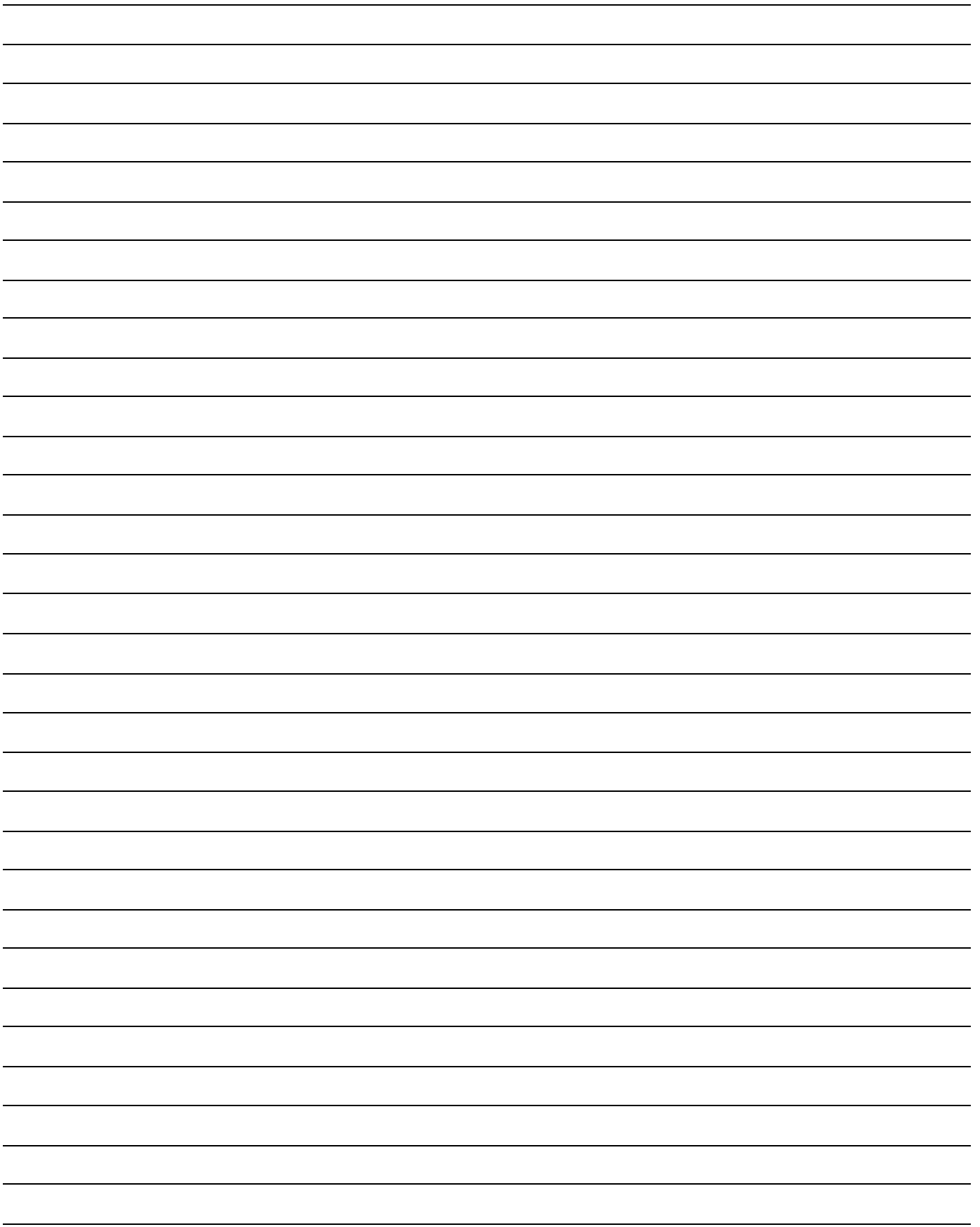

Part Number 1781267

Bayliner • P.O. Box 9029 • Everett, WA 98206 • 360-435-5571