

BAYLINER®

217 Deckboat

Owner's Manual *Supplement*

Engine Serial Number: _____

Hull Identification Number: _____

Hull Identification Number

- The Hull Identification Number (HIN) is located on the starboard hullside just forward of the transom.
- Record the HIN (and the engine serial numbers) in the space provided above.
- Include the HIN with any correspondence or orders.

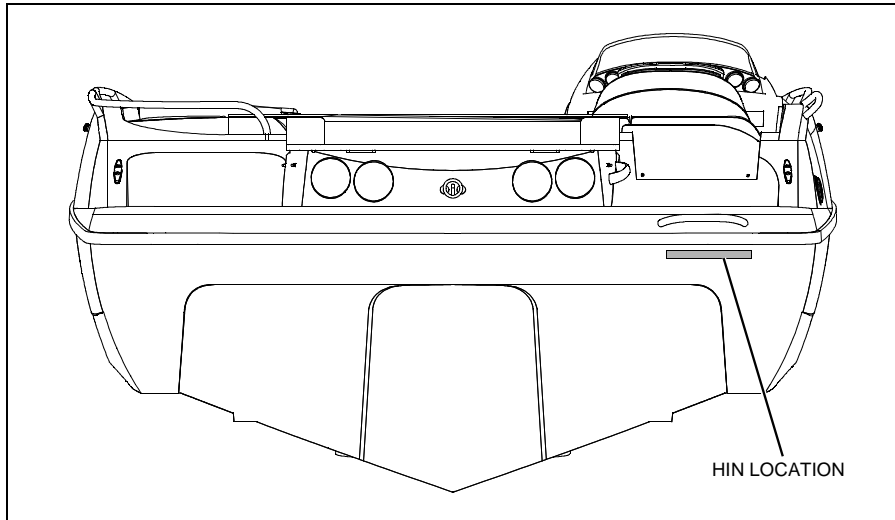

© 2005 Bayliner Technical Publications. All rights reserved.

No part of this publication may be reproduced, stored in any retrieval system, or transmitted in any form by any means, electronic, mechanical, photocopying, recording or otherwise, without prior written permission of Bayliner.
Printed in the United States of America.

General Notes

The material in this document is for information only and is subject to change without notice. While reasonable efforts have been made in the preparation of this document to assure its accuracy, Bayliner assumes no liability resulting from errors or omissions in this document, or from the use of information contained herein.

Due to our commitment to product improvement, Bayliner reserves the right to make changes in the product design, specifications, and equipment at any time without notice or obligation. Illustrations and/or photos may show optional equipment.

All Bayliner products meet or exceed USCG (United States Coast Guard) and/or NMMA (National Marine Manufacturer's Association) construction standards. Manufactured with 1,1,1 Trichloroethane, a substance which harms public health and environment during the manufacturing process by destroying ozone in the upper atmosphere.

Proprietary Rights

This document discloses subject matter in which Bayliner has proprietary rights. The information and design disclosed herein were originated by and are the property of Bayliner. Neither receipt nor possession thereof confers or transfers any right to reproduce, copy, alter or disclose the document or any part thereof, any information contained therein, or to construct boats or any item from it, except by written permission from or written agreement with Bayliner. This document is to be returned upon request to Bayliner.

CONTENTS

Chapter 1: Welcome Aboard!

- Dimensions & Tank Capacities 1
- Dealer Service 1
- Warranty Information 1
- Boating Experience 1
- Engine & Accessory Guidelines 2
 - Engine & Accessory Literature* 2
 - Propeller* 2
- Structural Limitations 2
- Qualified Maintenance 3
- Special Care for Moored Boats 3
- Safety Standards 4
- Carbon Monoxide (CO) 5
 - CO Facts* 5
 - Factors that Increase the Effects of CO Poisoning* 5
 - Where & How CO Can Accumulate* 6
 - How to Protect Yourself & Others From CO* 6
 - CO Checklists* 7
 - More Information* 7
- Warnings & Warning Labels 8

Chapter 2: Locations

- Exterior Views 10
 - Hull Views* 10
 - Deck View* 11
 - Helm* 12
- Component Locations 13

Chapter 3: Propulsion & Related Systems

- Engine 21
- Bilge Blower System 21
- Fuel System 22
 - Fuel Fill & Vent* 22
 - Fuel Filters* 23
 - Anti-siphon Valve* 23
- Quick Oil Drain System 24

Chapter 4: Controls & Gauges

- Steering 25
- Shift/Throttle Controls 25
- Power Trim & Tilt 25
- Gauges 26
 - Cleaning the Gauges* 26
 - Gauge Fogging* 26
 - Radio Transmission Interference* 26
 - Fuel Gauge* 26
- Depth Finder(s) (If Equipped) 26

Chapter 5: Plumbing

Bilge Pumps 27

Bilge Pump Testing 28

Autofloat Switches 29

Livewell System (If Equipped) 30

Seacocks 30

Filling & Using the Livewell 31

Freshwater System (If Equipped) 32

Transom Shower (If Equipped) 32

Freshwater System Winterization 33

Drain Systems 34

Deck Drains 34

Sink Drain 34

Portable Toilet 34

Chapter 6: Deck Equipment

Cleats & Bow/Stern Eyes 35

Bow Mount Trolling Motor (If Equipped) 35

Ski-Tow Ring 35

Ski-Tow Tower (If Equipped) 36

Attaching the Ski-tow Rope 36

Folding the Ski-tow Tower 37

Tower Care 37

Canvas 38

Aft Bimini Top 38

Forward Bimini Top (If Equipped) 39

Canvas Care 40

Chapter 7: Entertainment Systems

Audio Equipment 41

Chapter 8: Convertible Seats, Beds, & Tables

Bow Sunlounge Conversion 42

Removable Fishing Seats (If Equipped) 44

Chapter 9: Lights

Care & Maintenance 45

Exterior Lights 45

Navigation Lights 45

Chapter 10: Electrical System

12-Volt DC System 47

Battery 47

Fuses 47

12-Volt DC Accessory Outlet 47

Alternator 47

Electrical Routings 48

12-Volt DC Deck Harnesses 48

Battery Cable Routing 49

Wiring Diagram 50

Important Records 51

Float Plan 52

Hazard Boxes & Symbols

The hazard boxes and symbols shown below are used throughout this supplement to call attention to potentially dangerous situations which could lead to either personal injury or product damage. Read *all* warnings carefully and follow *all* safety instructions.

 **DANGER!**
This box alerts you to immediate hazards which *WILL* cause severe personal injury or death if the warning is ignored.

 **WARNING!**
This box alerts you to hazards or unsafe practices which *COULD* result in severe personal injury or death if the warning is ignored.

 **CAUTION**
This box alerts you to hazards or unsafe practices which *COULD* result in minor personal injury or cause product or property damage if the warning is ignored.

NOTICE
This box calls attention to installation, operation or maintenance information, which is important to proper operation but is not hazard related.

 FIRE HAZARD!	 EXPLOSION HAZARD!	 NO OPEN FLAME!	 ELECTRICAL HAZARD!	 HOT HAZARD!
--	---	--	---	---

 FALLING HAZARD!	 ROTATING PROPELLER HAZARD!	 RUN BILGE BLOWERS FOR 4 MINUTES!
---	--	---

DANGER
CARBON MONOXIDE
CO POISONING
HAZARD!

Chapter 1: Welcome Aboard!

- This *Owner's Manual Supplement* provides information about your boat that is **not** covered in the *Sport Boat Owner's Manual*.
- **Before** using your boat, study this *Owner's Manual Supplement*, the *Sport Boat Owner's Manual*, and **all** engine and accessory literature carefully.
- Keep this *Owner's Manual Supplement* and the *Sport Boat Owner's Manual* on your boat in a secure, yet readily available place.

Dimensions & Tank Capacities

Overall Length	Length Rigged	Bridge Clearance	Beam	Draft (Hull)	Draft (Maximum)	Fuel Capacity	Freshwater Capacity
20' 7"	21' 2"	5' 0"	8' 6"	1' 4"	2' 8"	55 Gallons	10 Gallons

Dealer Service

- Your dealer is your key to service.
- Ask your dealer to explain **all** systems **before** taking delivery of your boat.
- Contact your dealer if you have any problems with your new boat.
- If your dealer cannot help, call our customer service hotline: 360-435-8957 or send us a FAX: 360-403-4235.
- Buy replacement parts from any authorized Bayliner dealer.

Warranty Information

- Bayliner offers a Limited Warranty on each new Bayliner purchased through an authorized Bayliner dealer.
- A copy of the Limited Warranty was included in your owner's packet.
- If you did not get a copy of the Limited Warranty, please contact your Bayliner dealer or call 360-435-8957 for a copy.

Boating Experience

WARNING!

CONTROL HAZARD!

A qualified operator *MUST* be in control of your boat at *ALL* times. Do *NOT* operate your boat while under the influence of alcohol or drugs.

If this is your first boat or if you are changing to a type of boat you are **not** familiar with, for your own comfort and safety, get handling and operating experience **before** assuming command of your boat.

Take one of the boating safety classes offered by the U.S. Power Squadrons or the U.S. Coast Guard Auxiliary. For more course information, including dates and locations of upcoming classes, contact the organizations directly:

- U.S. Power Squadrons: 1-888-FOR-USPS (1-888-367-8777) or on the Internet at: <http://www.usps.org>
- In Canada, for the CPS courses call 1-888-CPS-BOAT.
- U.S. Coast Guard Auxiliary: 1-800-368-5647 or on the Internet at: <http://www.cgaux.org>

Outside the United States, your selling dealer, national sailing federation, or local boat club can advise you of local sea schools or competent instructors.

Engine & Accessory Guidelines

NOTICE

When storing your boat, please refer to your engine's operation and maintenance manuals.

NOTICE

Certain modifications to your boat *WILL* result in cancellation of your warranty protection. *ALWAYS* check with your dealer *BEFORE* making any modifications to your boat.

- Your boat's engine and accessories were selected to provide optimum performance and service.
- Installing a different engine or other accessories may cause unwanted handling characteristics.
- Should you choose to install a different engine or accessories that will affect your boat's running trim, have an experienced marine technician perform a safety inspection and handling test *before* operating your boat again.

Engine & Accessory Literature

- The engine and accessories installed on your boat come with their own operation and maintenance manuals.
- Read these manuals *before* using the engine and accessories.
- Unless noted otherwise, *all* engine and accessory literature referred to in this *supplement* is included in your owner's packet.

Propeller



CAUTION

ENGINE DAMAGE HAZARD!

The factory standard propeller may not be the best for your particular boat and load conditions. Refer to the engine manual for engine RPM ratings. The engine should reach, but not exceed its full rated RPM when full-throttle is applied.

Immediately contact your local Bayliner dealer if:

- The engine cannot reach its full rated RPM when full-throttle is applied, or;
- The engine exceeds its full rated RPM when full-throttle is applied.

- Keep the propeller in good repair and at the correct pitch for your particular situation.
- A slightly bent or nicked propeller will adversely affect the performance of your boat.

Structural Limitations

The swim platform extension (if equipped) is designed to be lightweight for proper boat balance. The load limit for the swim platform extension is 30 pounds per square foot, evenly distributed.

Qualified Maintenance



WARNING!

To maintain the integrity and safety of your boat, allow *ONLY* qualified personnel to perform maintenance on, or change, in any way, the:

- Steering system
- Propulsion system
- Engine control system
- Fuel system
- Environmental control system
- Electrical system
- Navigational system

- Failure to maintain your boat's systems (listed in the warning above) as designed could violate the laws in your jurisdiction and could expose you and other people to the danger of bodily injury or accidental death.
- Follow the instructions provided in the *Sport Boat Owner's Manual*, this *supplement*, the engine owner's manual, and *all* accessory literature.

Special Care for Moored Boats

NOTICE

- To help seal the hull bottom and reduce the chance of gel coat blistering while your boat is moored, apply an epoxy barrier coating.
- The barrier coating should be covered with several coats of anti-fouling paint.
- Many states regulate the chemical content of bottom paints in order to meet environmental standards. Check with your local dealer about recommended bottom paints, and about the laws in effect in your area.

- Whether moored in saltwater or freshwater, your boat will collect marine growth on its hull bottom.
- This will detract from your boat's beauty, greatly affect its performance, and may damage the gel coat.
- Periodically haul your boat out of the water and scrub the hull bottom with a bristle brush and a solution of soap and water.

Safety Standards

⚠ DANGER!



FALLING and ROTATING PROPELLER HAZARD!

- **NEVER** allow anyone to ride on parts of your boat **NOT** designed for such use.
- Sitting on seat-backs, lounging on the forward deck, bow riding, gun-wale riding or occupying the transom platform while underway is especially hazardous and **WILL** cause personal injury or death.

⚠ DANGER!





ROTATING PROPELLER and CARBON MONOXIDE POISONING HAZARD!

- **NEVER** allow anyone to occupy, or hang from, the back deck or swim platform while the engine(s) are running.
- Teak surfing, dragging, or water skiing within 20 feet of a moving watercraft can be fatal.

⚠ DANGER!

PERSONAL SAFETY HAZARD!

- **ALWAYS** secure the anchor and other loose objects **BEFORE** getting underway.
- The anchor and other items that are **NOT** properly secured can come loose when your boat is moving and cause personal injury or death.

⚠ WARNING!

A wide variety of components used on this vessel contain or emit chemicals known to the State of California to cause cancer and birth defects and other reproductive harm.

Examples Include:

- Engine and generator exhaust
- Engine and generator fuel, and other liquids such as coolants and oil, especially used motor oil
- Cooking fuels
- Cleaners, paints, and substances used for vessel repair
- Waste materials that result from wear of vessel components
- Lead from battery terminals and from other sources such as ballast or fishing sinkers

To Avoid Harm:

- **Keep away from engine, generator, and cooking fuel exhaust fumes.**
- **Wash exposed skin thoroughly with soap and water after handling the substances above.**

- Your boat's mechanical and electrical systems were designed to meet safety standards in effect at the time it was built.
- Some of these standards were mandated by law, and all of them were designed to insure your safety and the safety of other people, vessels and property.

Read this *supplement*, the *Sport Boat Owner's Manual*, and **all** accessory instructions for important safety standards and hazard information.

Carbon Monoxide (CO)

⚠ DANGER!	
	<ul style="list-style-type: none"> • Carbon monoxide gas (CO) is colorless, odorless, tasteless, and extremely dangerous. • <i>All</i> engines, generators, and fuel burning appliances produce CO as exhaust. • Prolonged exposure to low concentrations or very quick exposure to high concentrations will cause <i>BRAIN DAMAGE</i> or <i>DEATH</i>. • Teak surfing, dragging, or water skiing within 20 feet of a moving watercraft can be fatal.

CO Facts

- CO poisoning causes a significant number of boating deaths each year.
- Called the "silent killer", CO is an extremely toxic, colorless, odorless and tasteless gas.
- CO can harm or even kill you inside or outside your boat.
- CO can affect you whether you're underway, moored, or anchored.
- CO symptoms are similar to seasickness or alcohol intoxication.
- CO can make you sick in seconds. In high enough concentrations, even a few breaths can be fatal.
- Breathing CO blocks the ability of your blood to carry oxygen.
- The effects are cumulative. Even low levels of exposure can result in injury or death.

Factors that Increase the Effects of CO Poisoning

- Age
- Smokers or people exposed to high concentrations of cigarette smoke
- Consumption of alcohol
- Lung disorders
- Heart problems
- Pregnancy

Where & How CO Can Accumulate

Stationary conditions that increase CO accumulations include:

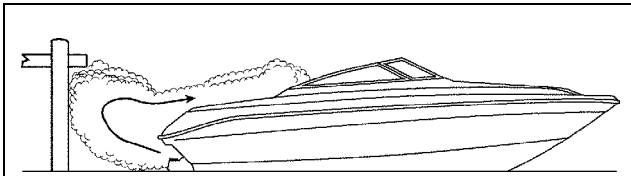

A. Using engine, generator, or other fuel burning device when boat is moored in a confined space.

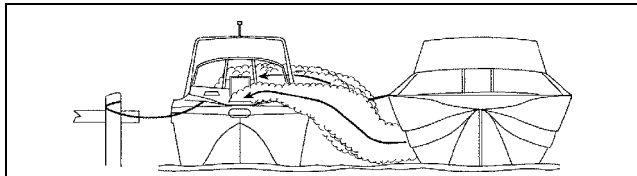

B. Mooring too close to another boat that is using its engine, generator, or other fuel burning device.

To correct stationary situations A and/or B:

- **Close all** windows, portlights and hatches.
- If possible, move your boat away from source of CO.

Running conditions that increase CO accumulations include:

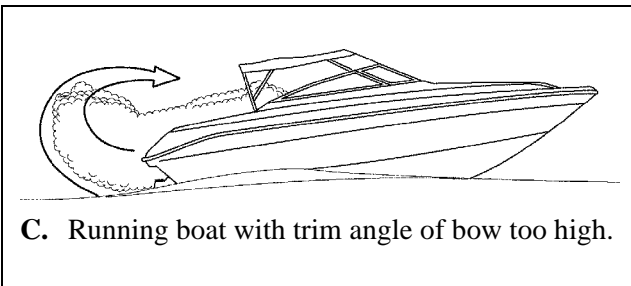

C. Running boat with trim angle of bow too high.

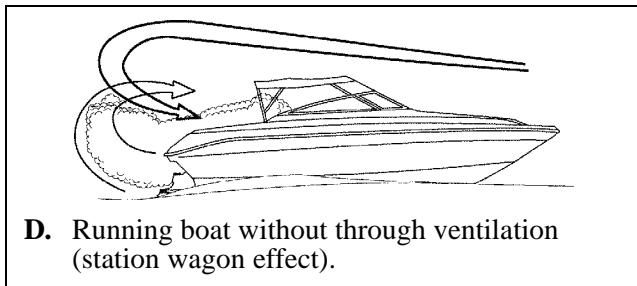

D. Running boat without through ventilation (station wagon effect).

To correct running situations C and/or D:

- Trim bow down.
- **Open** windows and canvas.
- When possible, run boat so that prevailing winds help dissipate exhaust.

How to Protect Yourself & Others From CO

- Know where and how CO may accumulate in and around your boat (see above).
- **Always** maintain fresh air circulation throughout your boat.
- Know where your engine and generator exhaust outlets are located and keep everyone away from these areas.
- **Never** sit on, or hang onto, the back deck or swim platform while the engine is running.
- **Never** enter the areas under swim platforms where exhaust outlets are located.
- Although CO can be present without the smell of exhaust fumes, if exhaust fumes are detected on your boat, take **immediate** action to dissipate these fumes.
- Treat symptoms of seasickness as possible CO poisoning. Get the person into fresh air **immediately**. Seek medical attention—unless you're sure it's **not** CO.
- Install and maintain CO monitors inside your boat. **Never** ignore any alarm. Replace monitors as recommended by the monitor manufacturer.
- Follow the checklists provided on the next page.
- Get a Vessel Safety Check.

For information on how to get a free VESSEL SAFETY CHECK, visit www.vesselsafetycheck.org or contact your local U.S. Coast Guard Auxiliary or United States Power Squadrons®.

- U.S. Coast Guard Auxiliary: 1-800-368-5647 or on the Internet at: <http://www.cgaux.org>
- U.S. Power Squadrons: 1-888-FOR-USPS (1-888-367-8777) or on the Internet at: <http://www.usps.org>

CO Checklists

Trip Checklist

- Make sure you know where the exhaust outlets are located on your boat.
- Educate *all* passengers about the symptoms of CO poisoning and where CO may accumulate.
- When docked, or rafted with another boat, be aware of exhaust emissions from the other boat.
- Listen for any change in exhaust sound, which could mean an exhaust component failure.
- Test the operation of each CO monitor by pressing the test button.

Monthly Checklist

- Make sure *all* exhaust clamps are in place and secure.
- Look for exhaust leaking from exhaust system components. Signs include rust and/or black streaking, water leaks, or corroded or cracked fittings.
- Inspect rubber exhaust hoses for burned, cracked, or deteriorated sections. *All* rubber hoses should be pliable and free of kinks.

Annual Checklist

Have a Qualified Marine Technician:

- Replace exhaust hoses if cracking, charring, or deterioration is found.
- Ensure that your engines and generators are properly tuned, and well maintained.
- Inspect each water pump impeller and the water pump housing. Replace if worn. Make sure cooling systems are in working condition.
- Inspect *all* metallic exhaust components for cracking, rusting, leaking, or loosening. Make sure they check the cylinder head gasket, exhaust manifold, water injection elbow, and the threaded adapter nipple between the manifold and the elbow.
- Clean, inspect, and confirm proper operation of the generator cooling water anti-siphon valve (if equipped).

More Information

For more information about how you can prevent carbon monoxide poisoning on recreational boats and other ways to boat more safely, contact:

United States Coast Guard
Office of Boating Safety (G-OPB-3)
2100 Second Street SW
Washington, DC 20593
www.uscgboating.org
1-800-368-5647

National Marine Manufacturers
Association (NMMA)
200 East Randolph Drive
Suite 5100
Chicago, IL 60601-9301
www.nmma.org
312-946-6200

American Boat & Yacht Council, Inc.
(ABYC)
3069 Solomon's Island Road
Edgewater, MD 21037-1416
www.abycinc.org
410-956-1050

For information on how to get a free VESSEL SAFETY CHECK, visit www.vesselsafetycheck.org or contact your local U.S. Coast Guard Auxiliary or United States Power Squadrons®.

- U.S. Coast Guard Auxiliary: 1-800-368-5647 or on the Internet at: <http://www.cgaux.org>
- U.S. Power Squadrons: 1-888-FOR-USPS (1-888-367-8777) or on the Internet at: <http://www.usps.org>



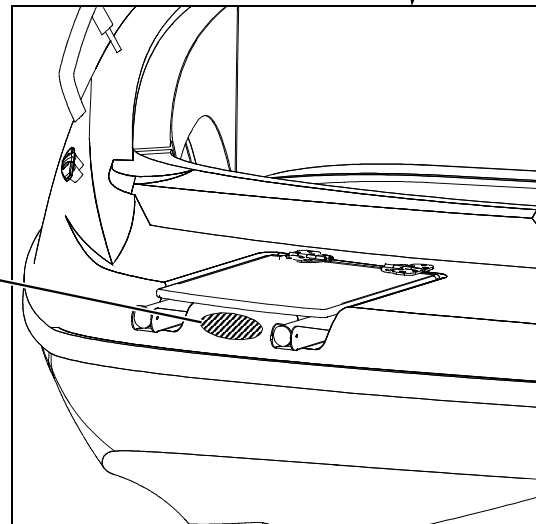
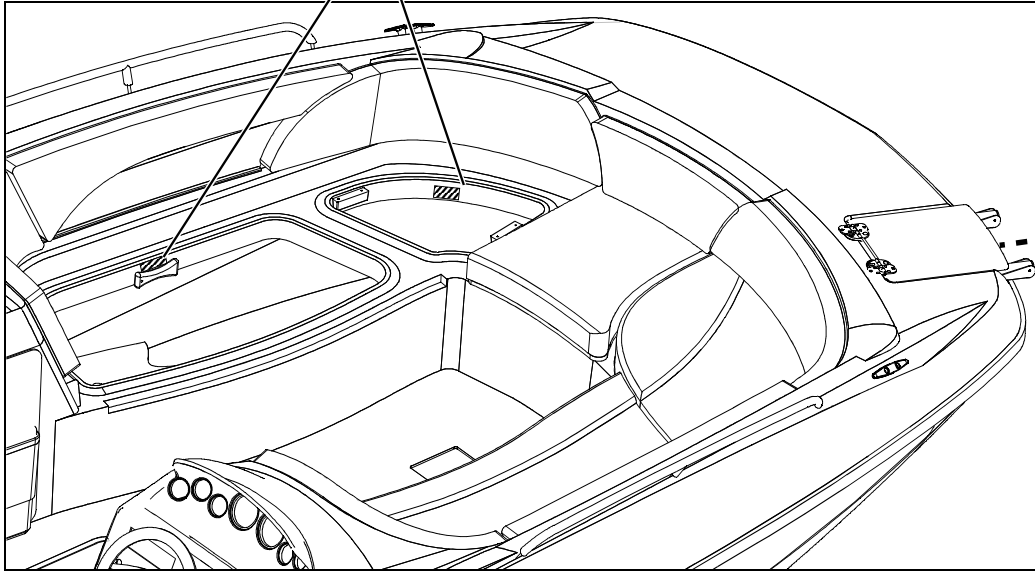

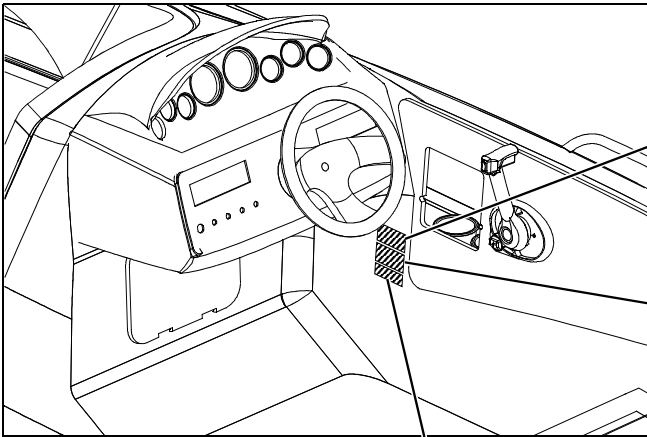
Warnings & Warning Labels





⚠ WARNING
 QUALIFIED OPERATOR TO BE IN CONTROL AT ALL TIMES. OPERATION BY AN UNQUALIFIED OPERATOR CAN CAUSE LOSS OF CONTROL. THIS MAY RESULT IN SEVERE INJURY, DEATH, OR PROPERTY DAMAGE. BOAT STABILITY AND HANDLING WILL CHANGE WITH WEIGHT DISTRIBUTION. READ OWNER'S MANUAL BEFORE USE.
 1706140

⚠ WARNING

   4 min 

GASOLINE VAPORS CAN EXPLODE. BEFORE STARTING, OPERATE BLOWER 4 MINUTES. CHECK ENGINE COMPARTMENT BILGE FOR FUEL VAPORS. RUN BLOWER BELOW CRUISING SPEED.
 1704247

⚠ WARNING
 ATTACH SHUT DOWN SWITCH LANYARD TO QUALIFIED OPERATOR WHILE ENGINE IS IN OPERATION. UNCONTROLLED BOAT MAY CAUSE INJURY OR DEATH. READ OWNER'S MANUAL BEFORE USE
 1703581

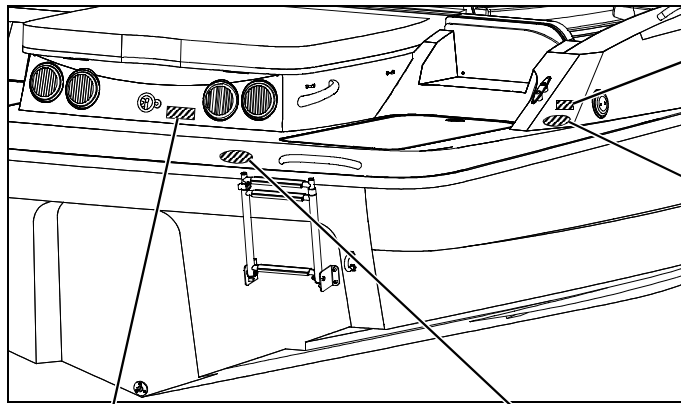

 **USE UNLEADED PETROL ONLY**
 65745

⚠ WARNING

 FUEL VAPORS MAY EXPLODE. INSPECT FUEL SYSTEM AT LEAST ANNUALLY.
 62966A

⚠ WARNING

 **TURNING PROPELLER. FALLING FROM SUNLOUNGE CAN CAUSE INJURY OR DEATH. STAY OFF SUNLOUNGE WHEN MOTOR IS RUNNING.**
 1705524

⚠ WARNING

 **DO NOT ATTEMPT TO BOARD OR USE THE LADDER IF MOTOR IS RUNNING.**
 62962

Chapter 2: Locations

Exterior Views

Hull Views

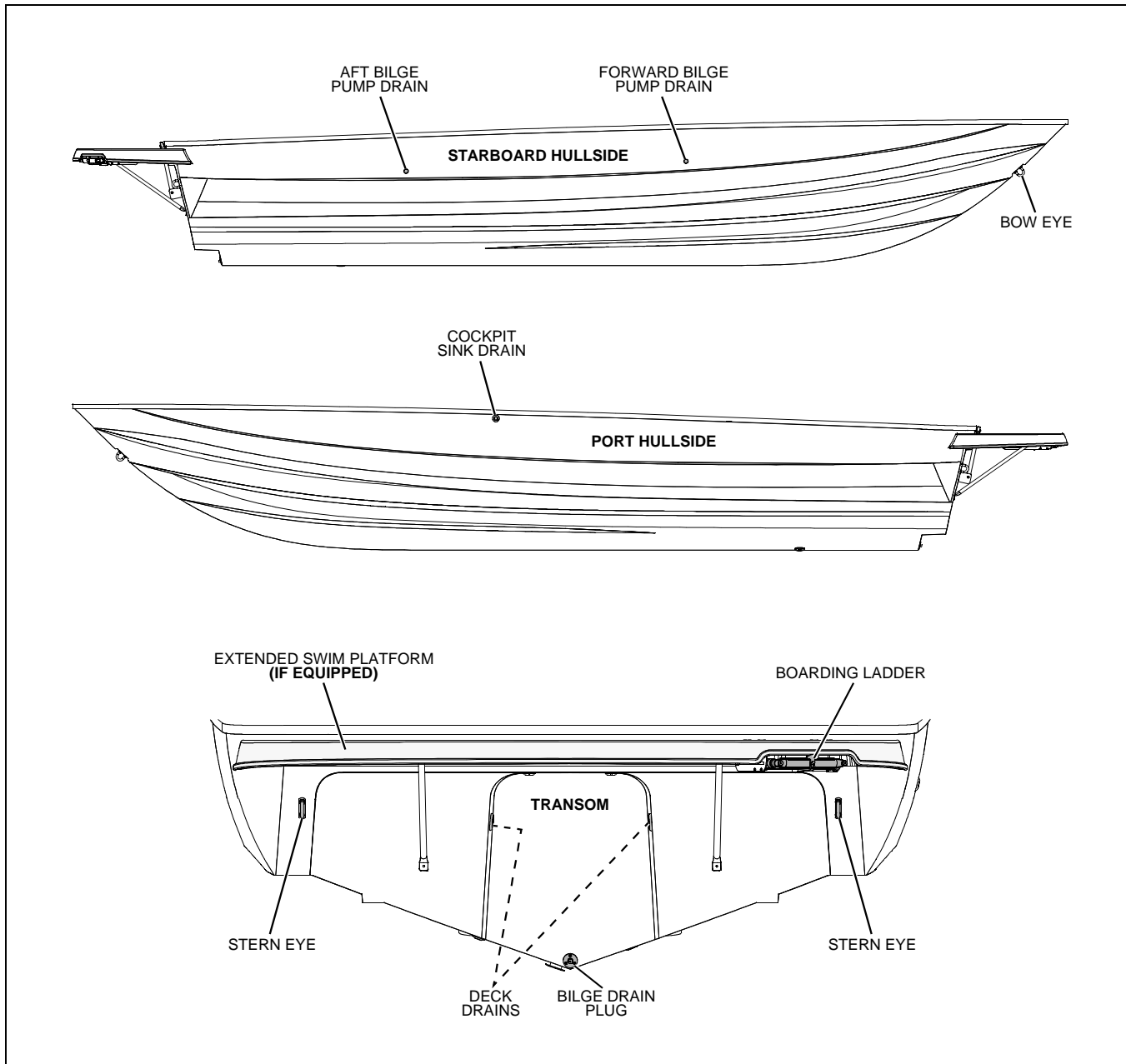

Deck View

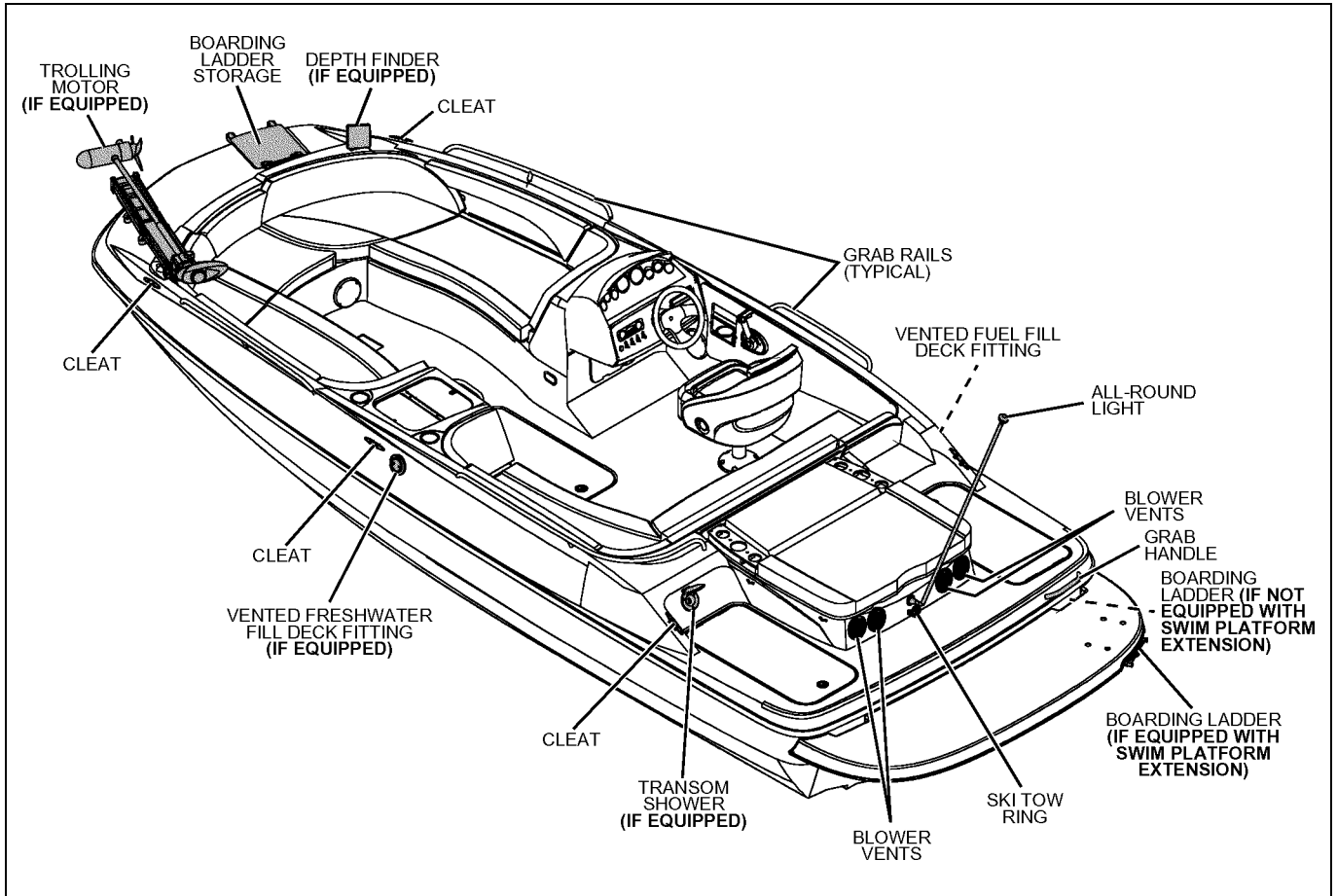

Helm

NOTE: TYPICAL HELM LAYOUT SHOWN
ACTUAL LAYOUT MAY VARY DEPENDING
ON ENGINE AND ACCESSORY OPTIONS

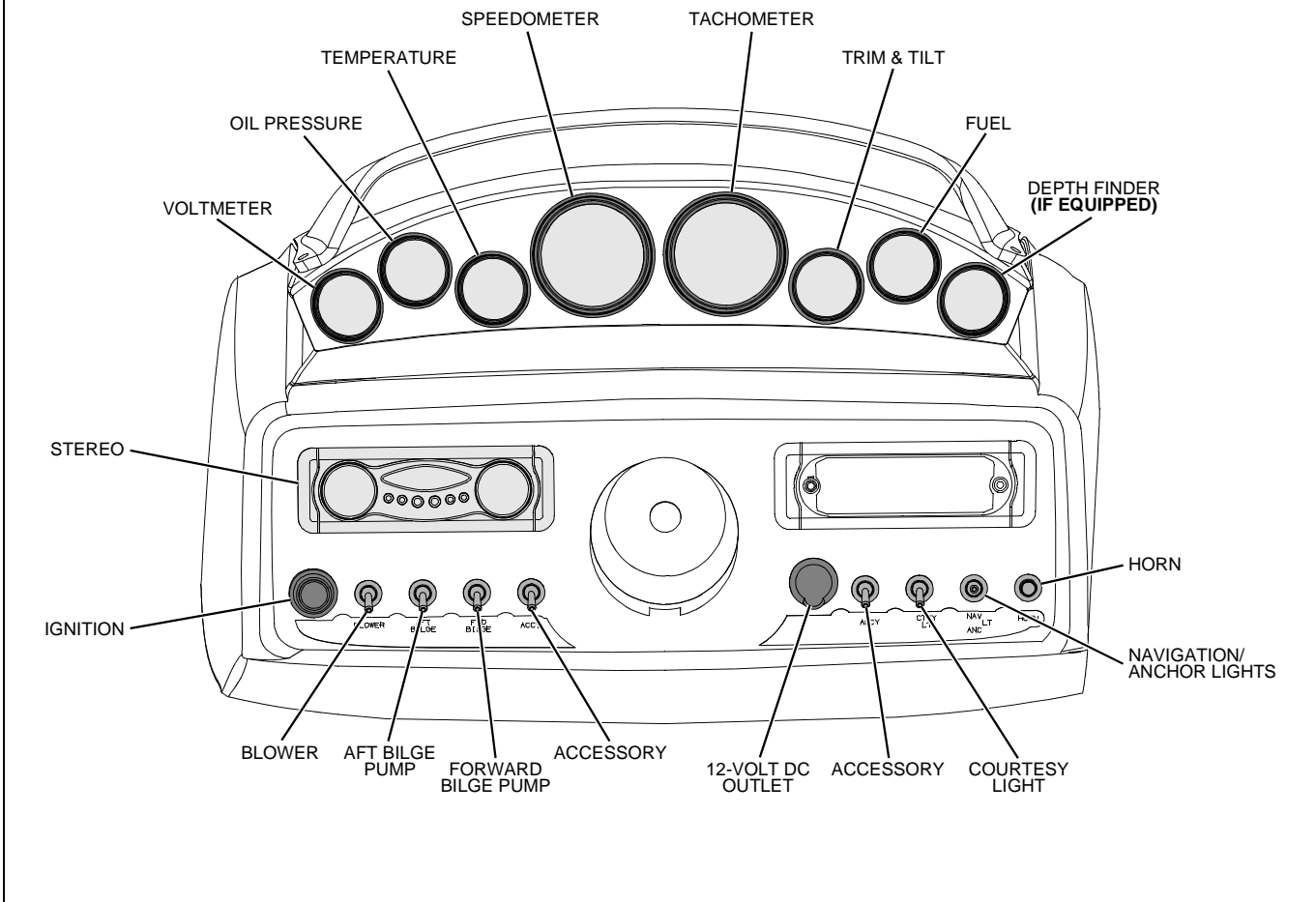

Component Locations

12-Volt DC Accessory Outlet:
 Located at the helm.

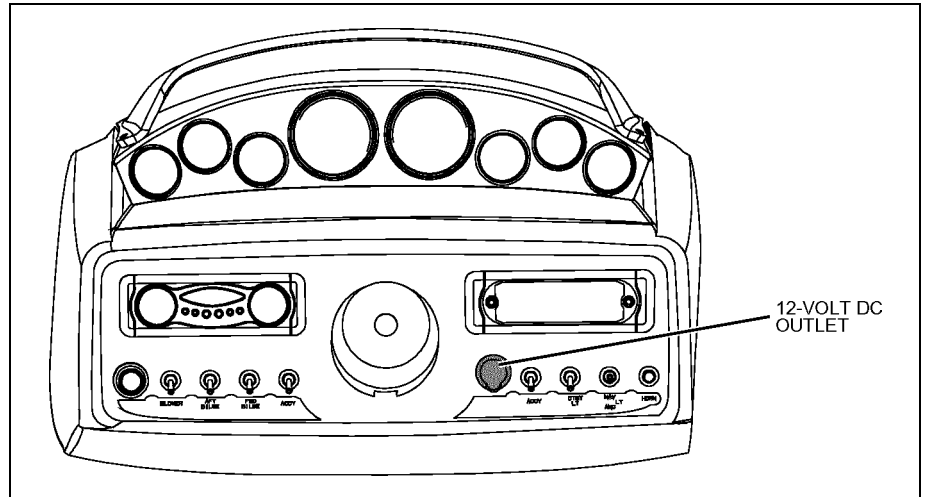

12-Volt DC Fuse Block: Located under the dash.

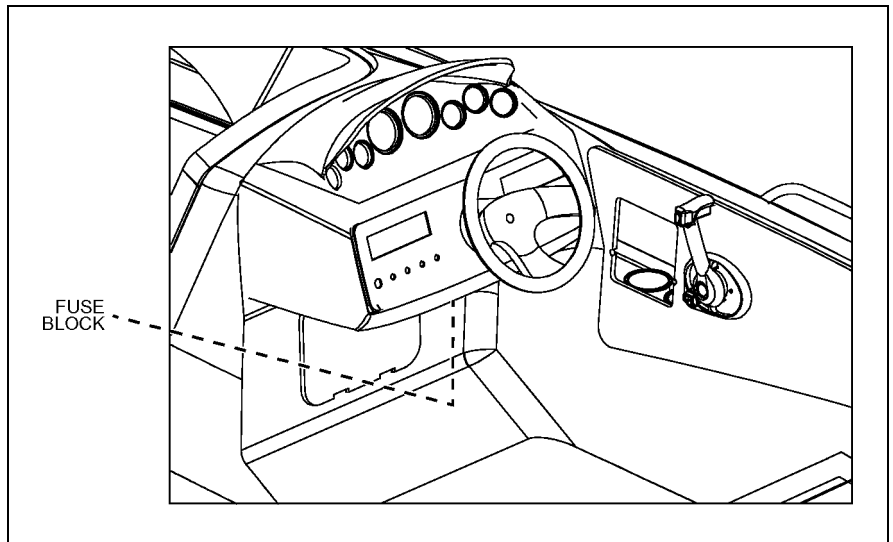

12-Volt DC Trolling Motor Circuit Breaker (If Equipped): Located under the port bow seat cushion.

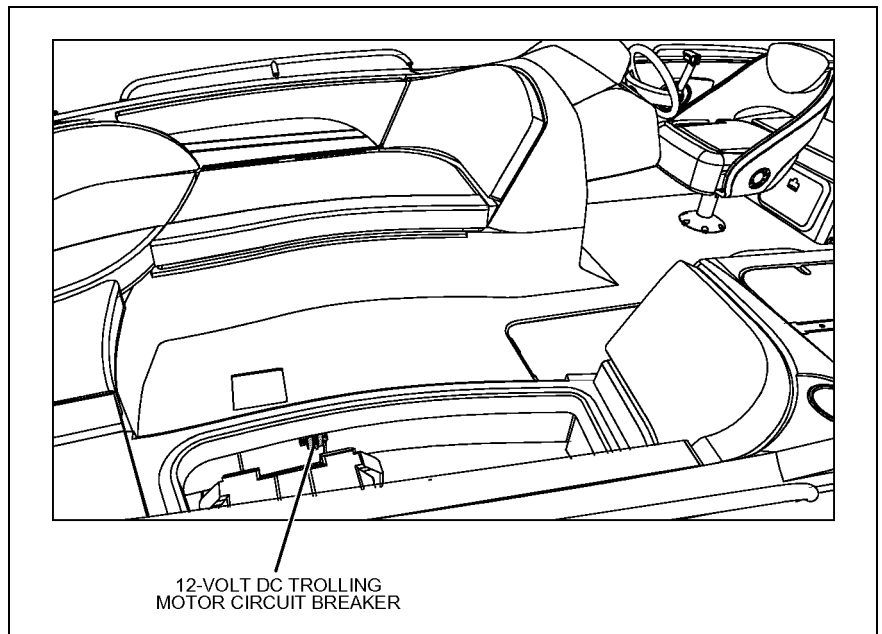

12-Volt DC Trolling Motor Receptacle (If Equipped): Located on the port side of the forward deck.

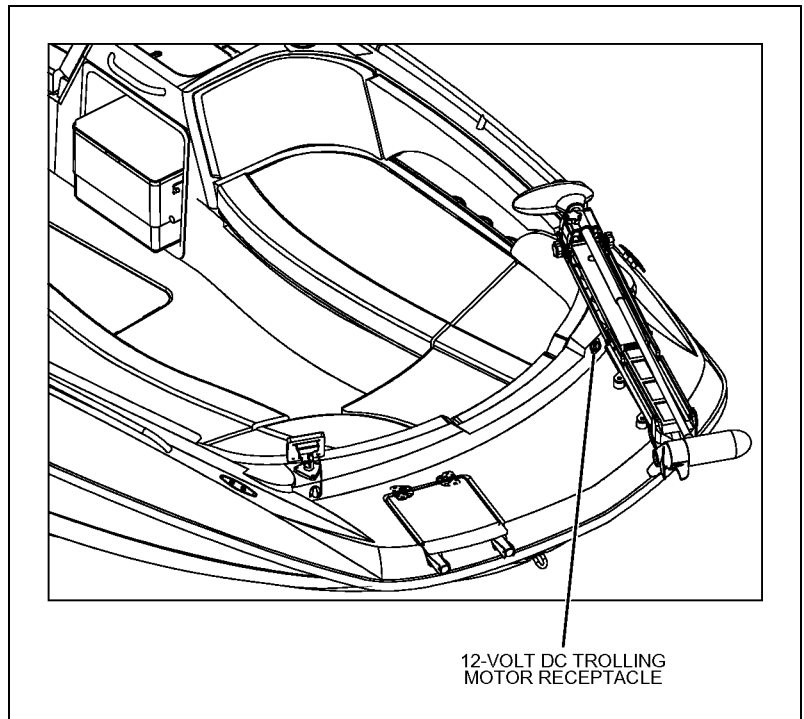

Battery: Located inside the port transom hatch.

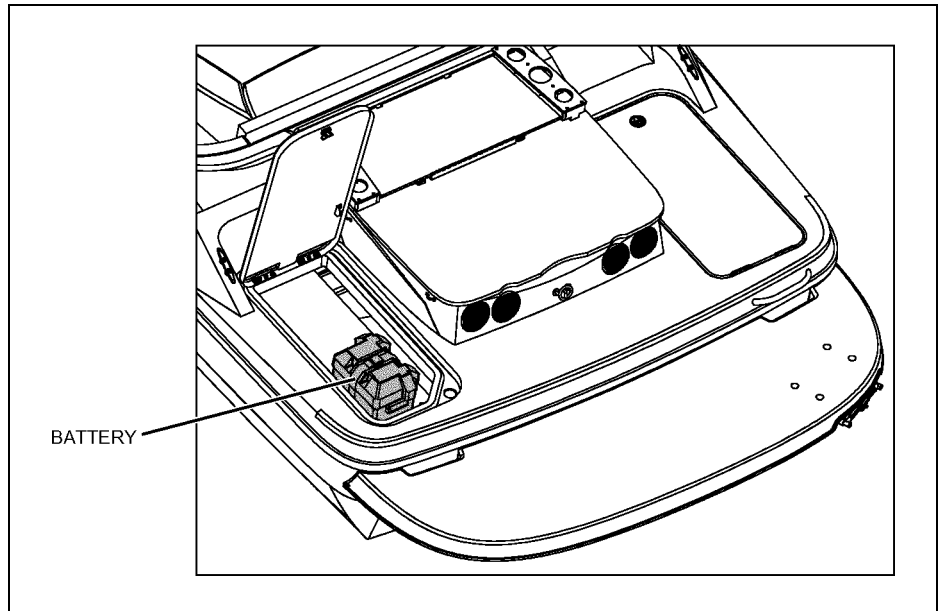

Bilge Pumps (2 Total):

- The aft bilge pump is located in the engine compartment bilge.

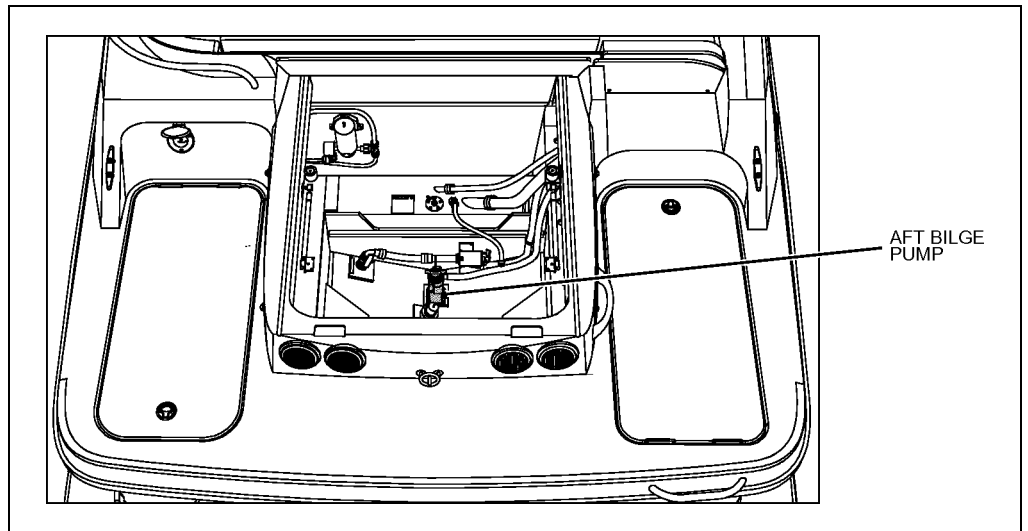

- The forward bilge pump is located in the cockpit floor hatch.

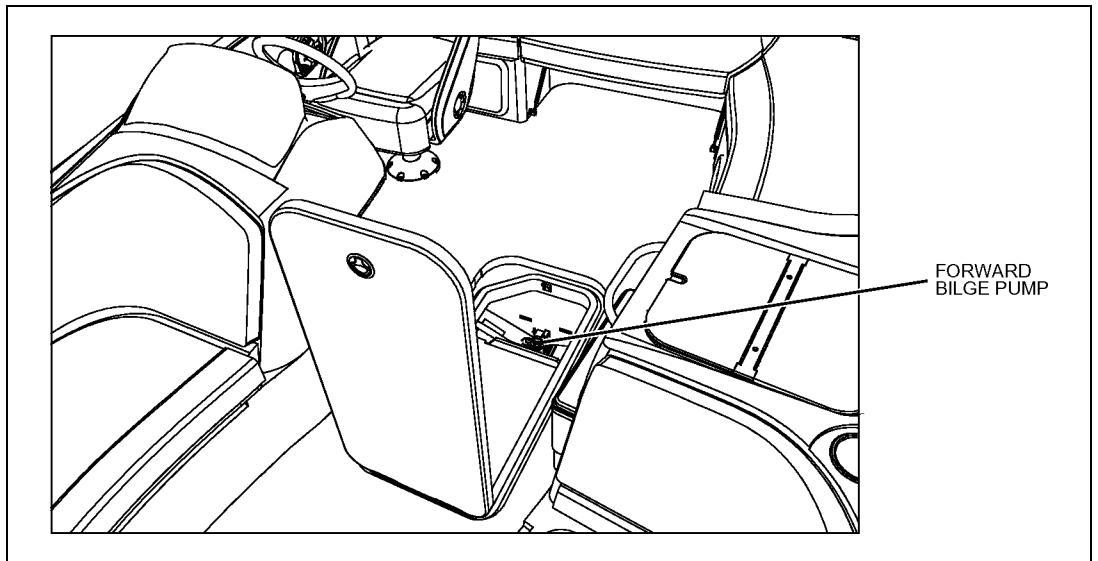

Blower Switch: Located at the helm.

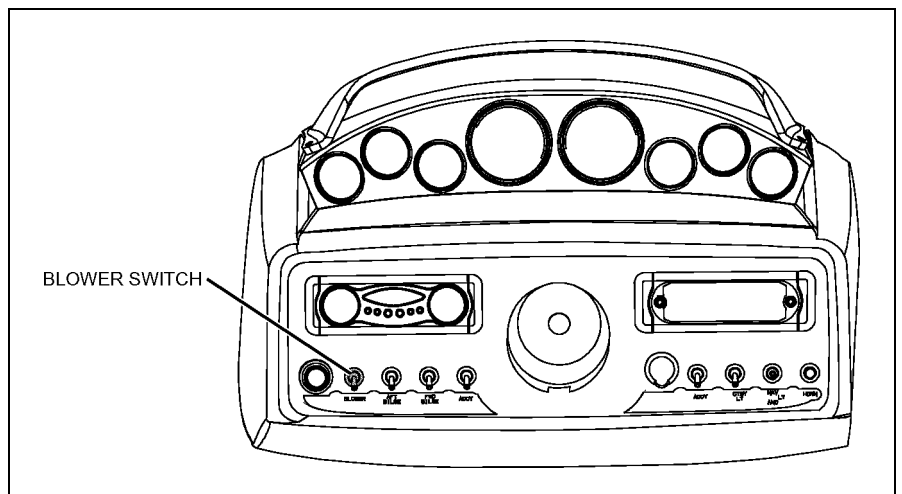

Depth Finder Transducer (If Equipped): Located in the engine compartment bilge.

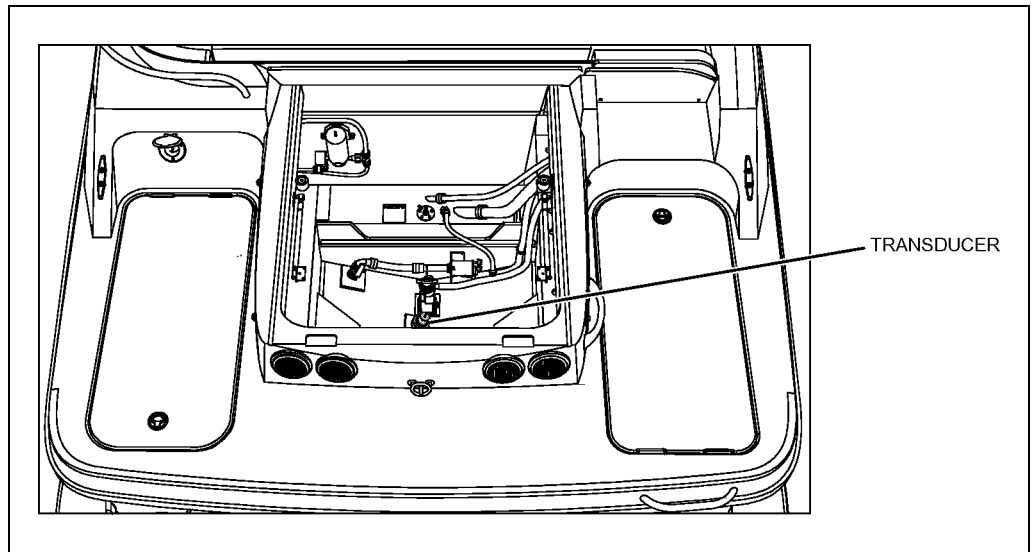

Freshwater Fill Deck Fitting (marked WATER) (If Equipped): Located on the port side of the deck.

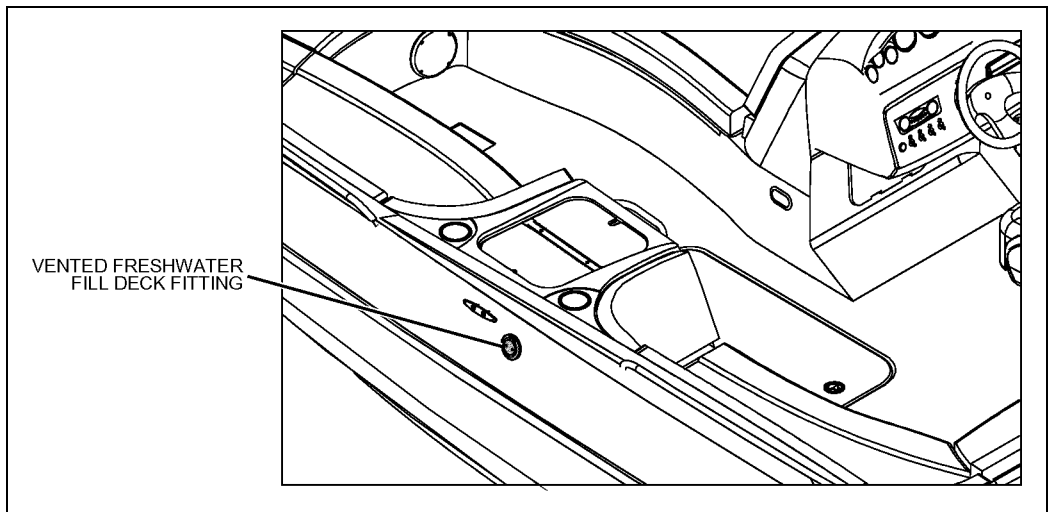

Freshwater Pump (If Equipped): Located on the forward wall in the engine compartment.

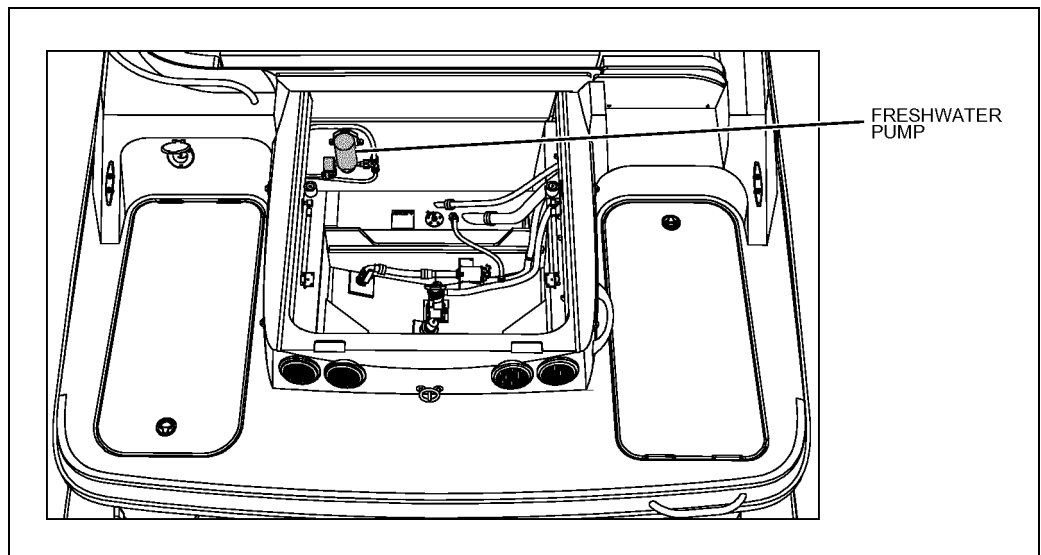

Freshwater Pump Switch (If Equipped): Located at the helm.

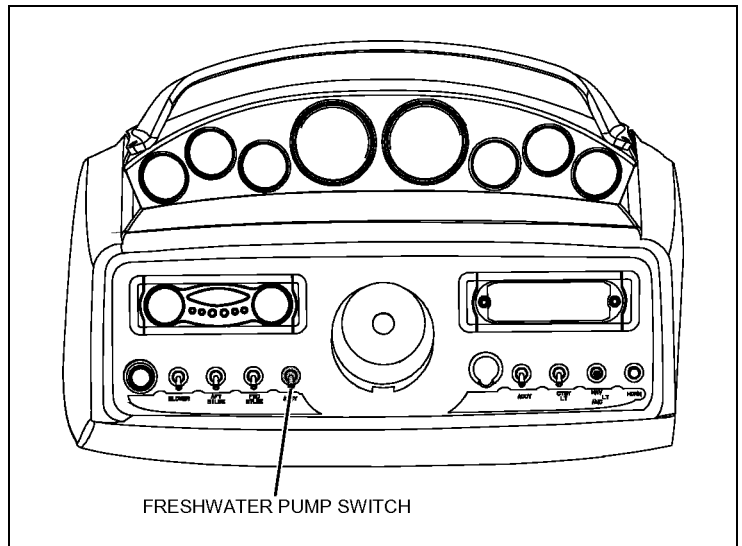

Freshwater Tank (If Equipped): Access by lifting the trash can hatch lid and removing the trash can.

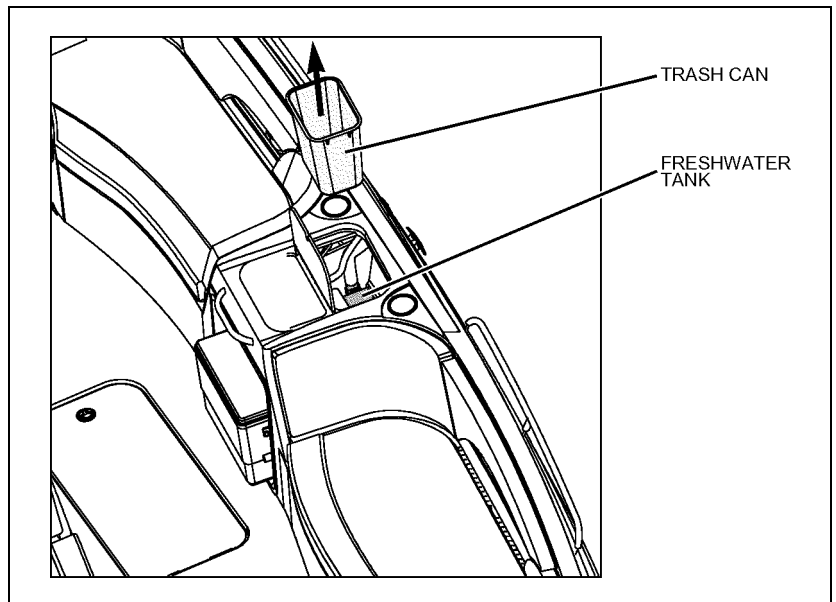

Fuel Fill Deck Fitting (marked GAS): Located on the starboard side of the deck.

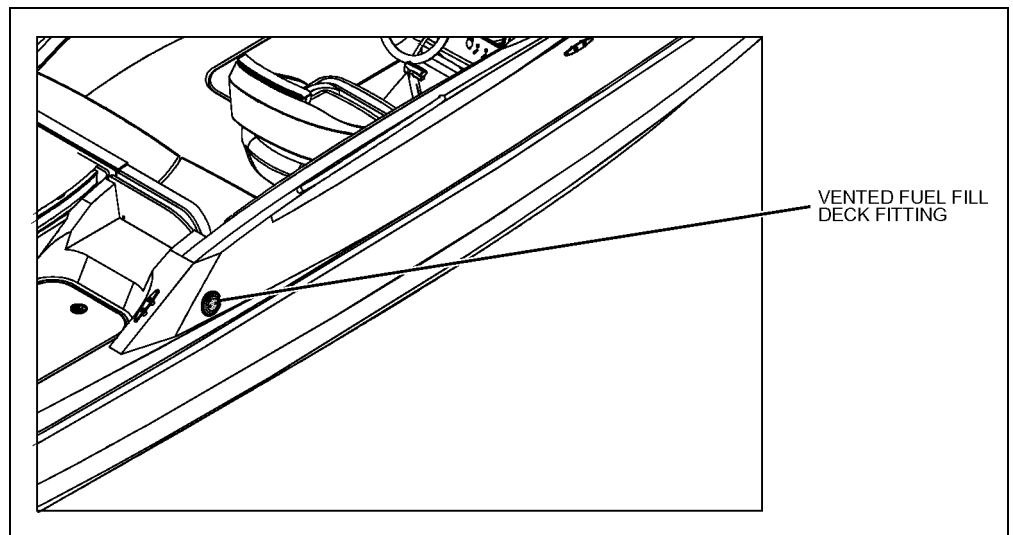

Fuel Tank, Tank Fittings, and Fuel Level Sending Unit: Located on the fuel tank, in the forward area of the engine compartment.

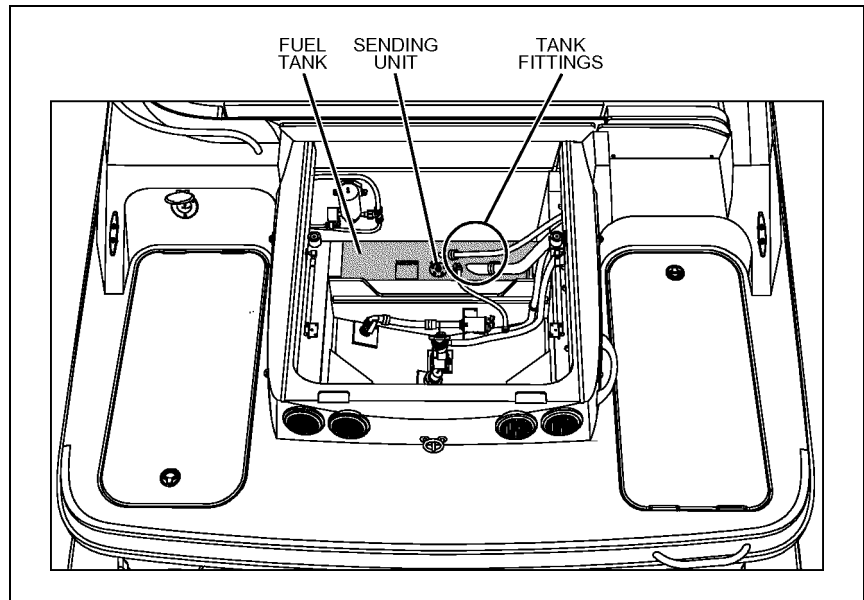

Livewell Aerator Control Valve (If Equipped):

- Located inside the livewell.
- Access by removing the starboard bow seat cushion and lifting the livewell hatch.

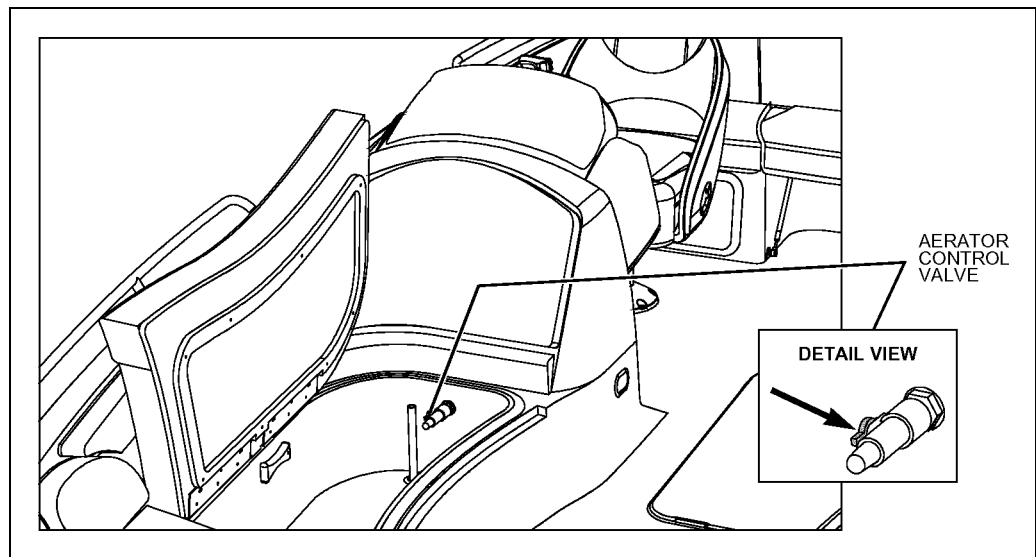

Livewell Drain Seacock (If Equipped):
Located in the cockpit floor hatch.

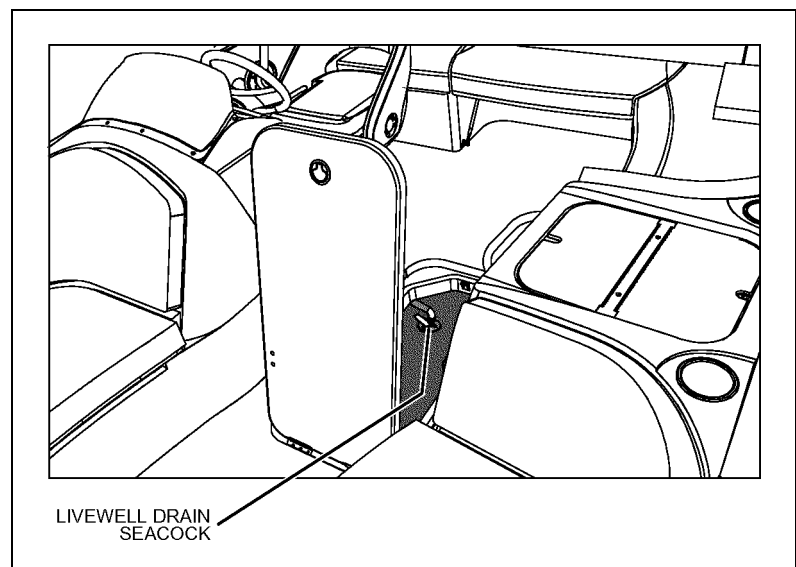

Livewell Pump Switch (If Equipped): Located at the helm.

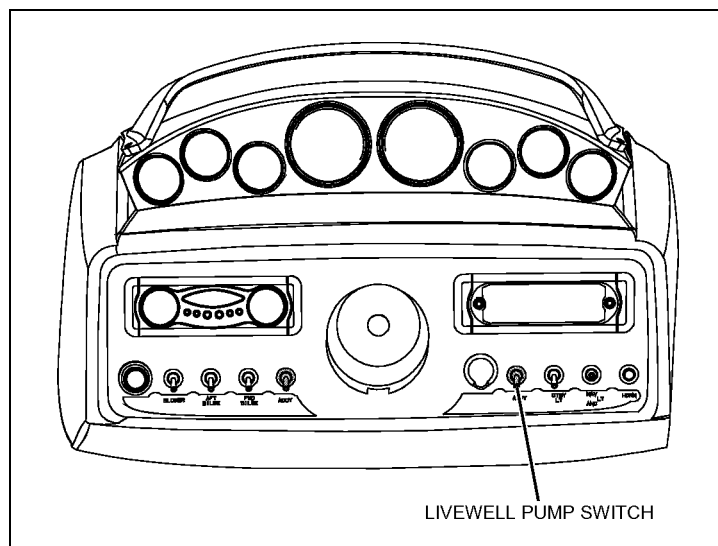

Livewell Seawater Intake Seacock (If Equipped): Located in the engine compartment bilge.

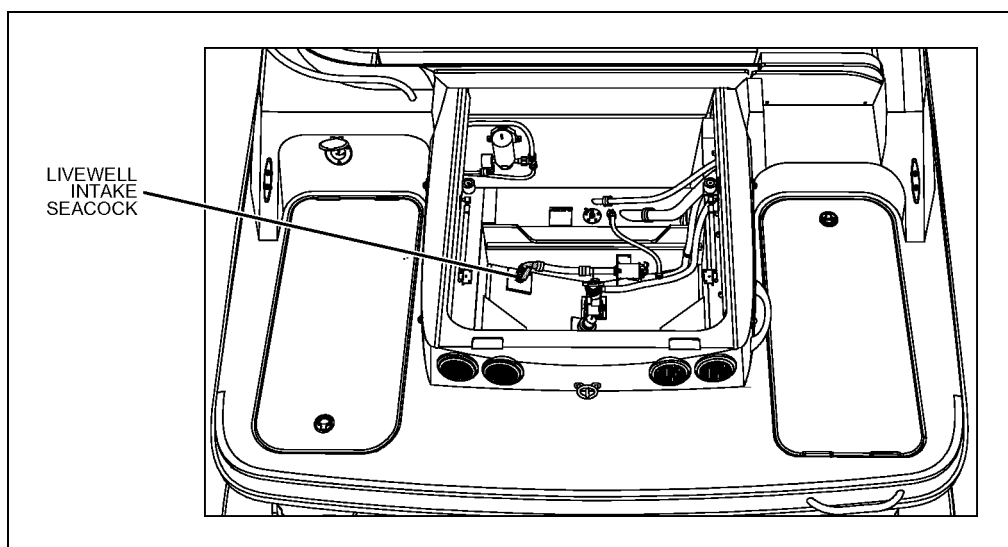

Navigation Lights:

- Red and green running lights on the forward deck.
- White all-round light on the aft deck.

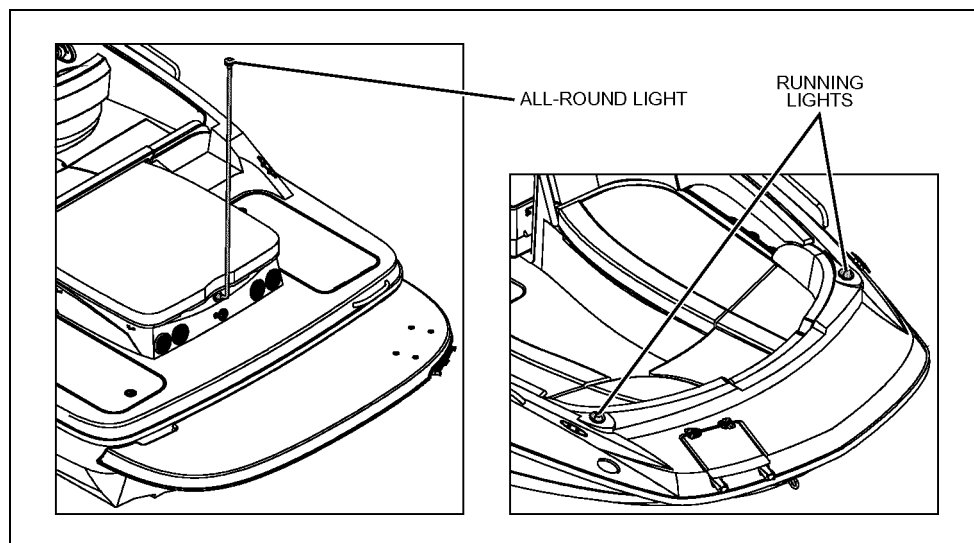

Portable Toilet: Located under the cockpit aft seat cushion.

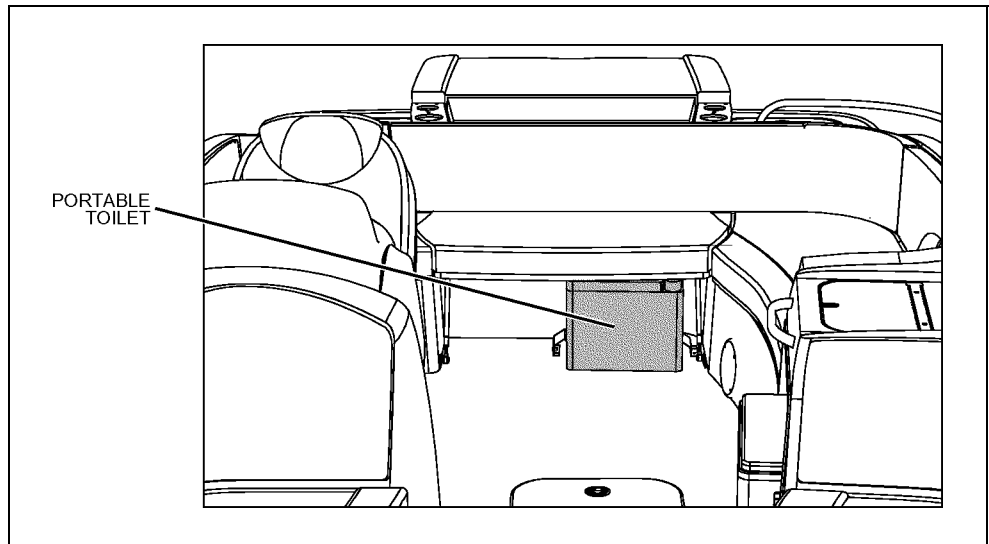

Transom Shower (If Equipped): Located on the port side of the aft deck.

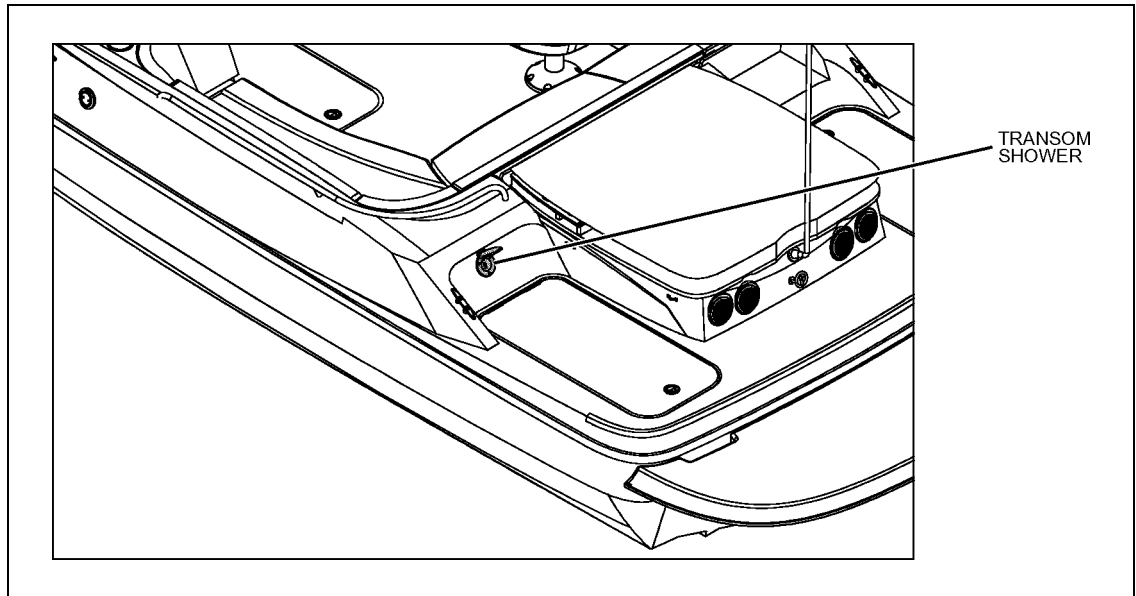

Trolling Motor (If Equipped): Located on the port side of the forward deck.

Trolling Motor Battery (If Equipped): Located under the port bow seat cushion.

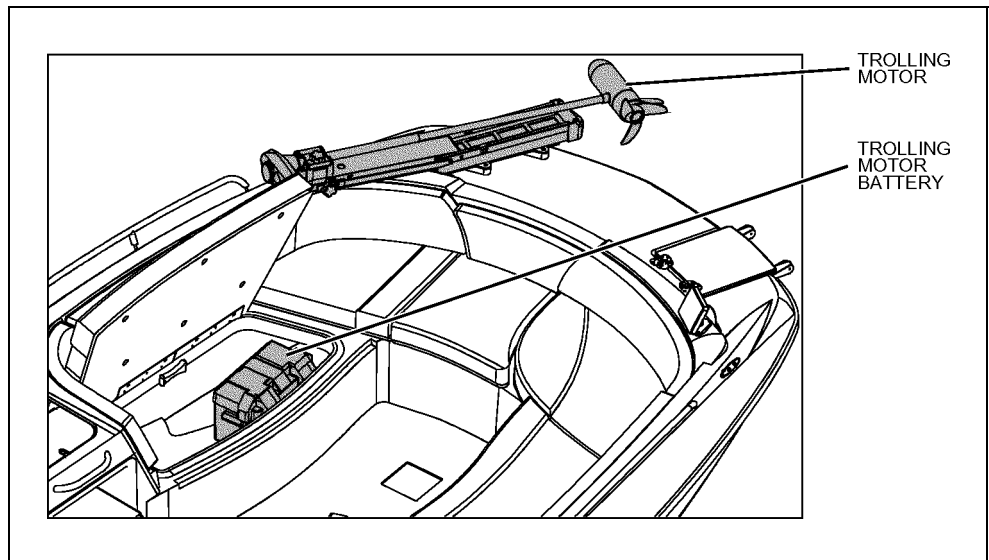

Chapter 3: Propulsion & Related Systems

Engine

Read the engine operation and maintenance manuals *before* starting or working on the engine.

Bilge Blower System

! WARNING!

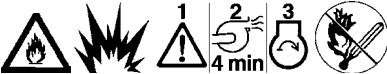

FIRE and EXPLOSION HAZARD!

Fuel vapors can explode! **BEFORE** starting the engine:

1. Check the bilge areas for fuel vapors or leaking fuel. If you see leaking fuel or smell fuel vapors:
 - a. Do **NOT** start the engine, do **NOT** turn **On** any electrical devices, extinguish **ALL** cigarettes, cigars, and other sources of flame or ignition.
 - b. Get everyone off your boat.
 - c. Get trained help to find and fix the problem.
2. Run the bilge blower for at least four minutes prior to engine starting, electrical system maintenance, or activation of electrical devices.
 - If you smell fuel vapors and the engine is already running;
 - a. Shut **Off** the engine and turn **Off ALL** electrical devices.
 - b. Extinguish **ALL** cigarettes, cigars, and other sources of flame or ignition.
 - c. Get trained help to find and fix the problem.
 - **NEVER** obstruct or change the bilge blower system.

- The bilge blower system removes explosive fumes from the engine and bilge areas.
- Fresh air is drawn into the engine and bilge areas through the vents.

To make sure the engine and bilge areas are properly ventilated:

- Use the "sniff test" to check the engine and bilge areas for fuel vapors *before* starting the engine.
- **Always** run the bilge blower for at least four minutes *before* starting the engine.
- Continue to run the blower until your boat has reached cruising speed.
- **Always** run the blower when running your boat below cruising speed.

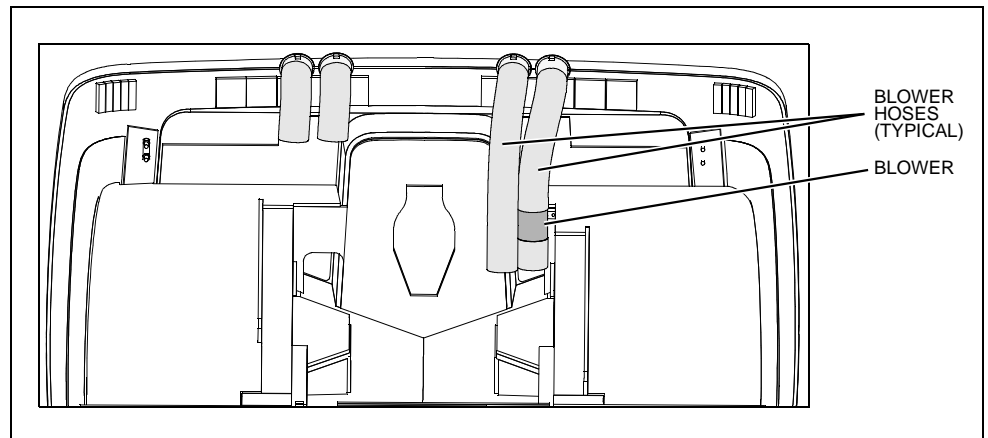

Fuel System

! WARNING!

 **FIRE, EXPLOSION, and OPEN FLAME HAZARD!**

- It is very important that the fuel system be inspected thoroughly the first time it is filled and at each subsequent filling.
- The fueling instructions in the *Sport Boat Owner's Manual* and the fuel recommendations in the engine operation manual **MUST** be followed.

! CAUTION

Avoid the storage or handling of gear near the fuel lines, fittings and tank.

NOTICE

Carefully read the fuel section of both the *Sport Boat Owner's Manual* and the engine operation manual, paying special attention to the subject of *fuel recommendations*.

Fuel Fill & Vent

- The fuel fill deck fitting is marked GAS.
- If you have problems filling the fuel tank, see if the fuel fill hose or fuel tank vent hose is kinked or collapsed.
- If there are no visible signs of a problem, contact your local dealer.

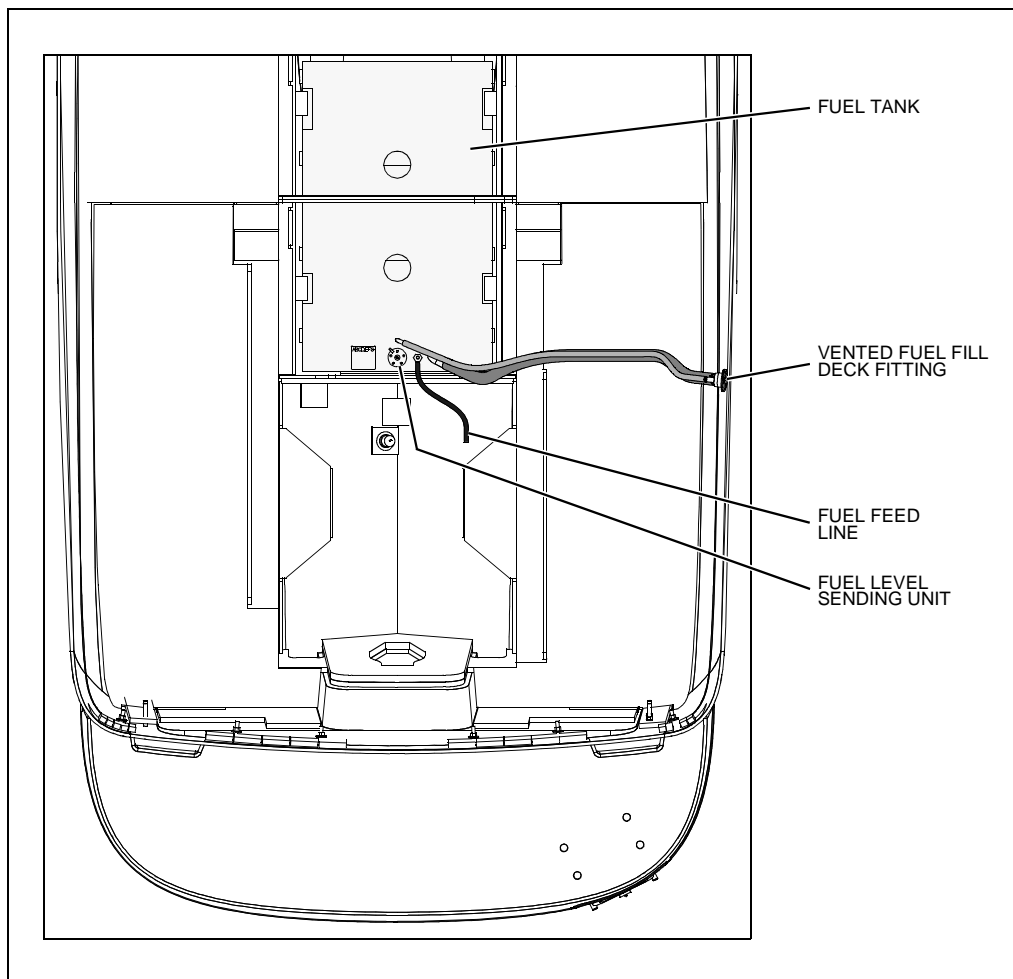

Fuel Filters

- The fuel pickup tube, located inside the fuel tank, is equipped with a fine mesh screen filter.
- Also, when supplied by the engine manufacturer, a fuel filter is installed on the engine.
- Periodically replace the fuel filters to make sure they remain clean and free of debris.
- Talk to your selling dealer or local marina about fuel additives that help prevent fungus or other buildup in your fuel tank.

Anti-siphon Valve

NOTICE

- **If an engine running problem is diagnosed as fuel starvation, check the anti-siphon valve.**
- **If the valve is stuck or clogged, *ONLY* change or replace it while the engine is *Off*.**
- ***NEVER* run the engine with the anti-siphon valve removed, except in an emergency.**

- The anti-siphon valve is a vital fuel system part.
- If the fuel line ruptures, this valve will prevent the fuel from siphoning from the tank.
- The valve is located on the fuel tank, where the fuel feed line attaches to the tank.
- The valve is spring loaded and is opened by fuel pump vacuum.

Quick Oil Drain System

The quick oil drain hose assembly was attached to the engine oil pan at the factory. However, some minor assembly is still needed *before* you can use this system.

NOTE: This is not the only method for changing your oil. Your selling dealer can recommend other methods.

How to install the quick oil drain system:

1. Unscrew the factory installed bilge plug from the bilge drain (A). **NOTE:** Keep the original factory bilge plug on your boat as a spare.
2. Unclip the quick oil drain assembly from the wire loop (B) on the engine.
3. Unclip the bilge plug's draw cord (C) from the oil drain plug's draw cord (D).
4. Thread the oil drain plug's draw cord (D) through the bilge drain (A).
5. Pull the oil drain plug (E), and the oil drain hose (F) through the bilge drain.
6. Adjust the hose stop clamp (G) so that no more than 12 inches of hose, including the oil drain plug, can extend out of the bilge drain (A).
7. Clip the bilge plug's draw cord (C) back to the oil drain plug's draw cord (D).
8. Push the oil drain hose, oil drain plug, and both draw cords through the bilge drain and into the bilge area.
9. Screw the bilge plug (H) into the bilge drain (A) and tighten firmly.

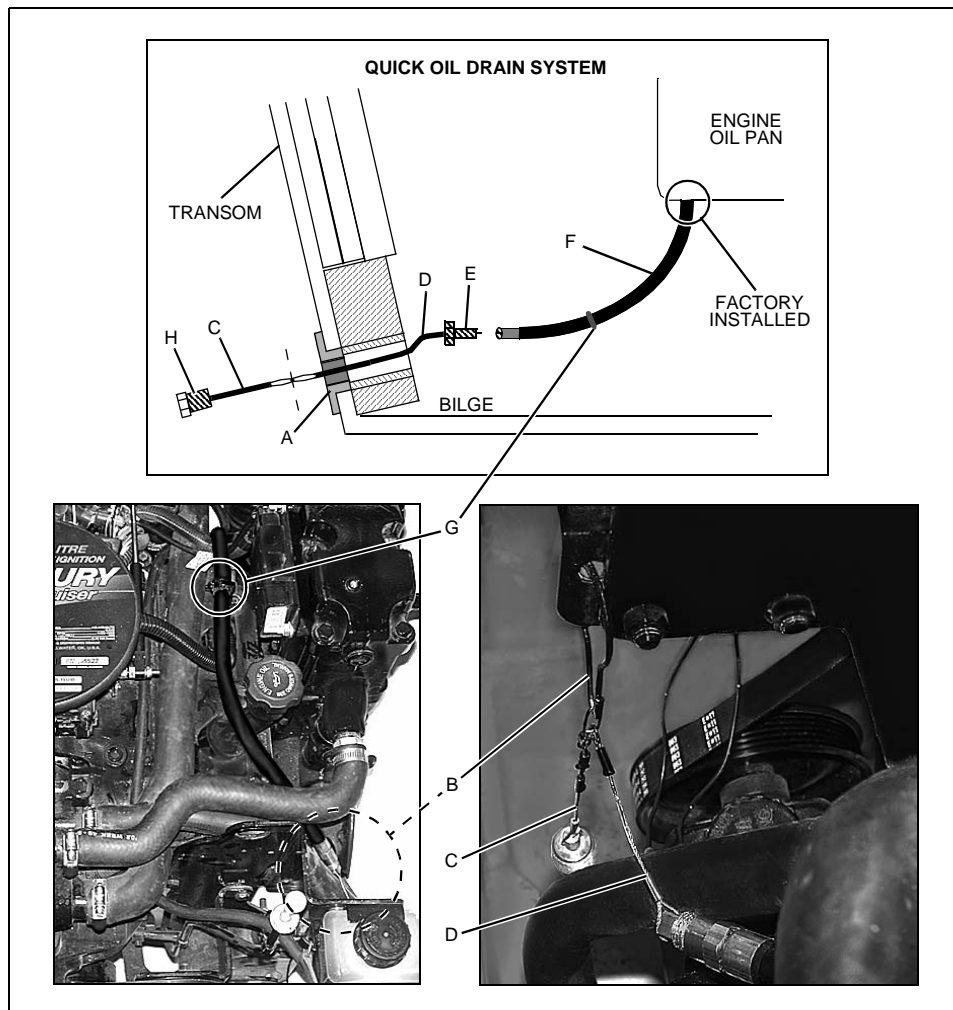

To drain the engine oil:

1. Remove your boat from the water.
2. Unscrew the bilge plug.
3. Pull the draw cord until the oil drain plug and the oil drain hose slide out of the bilge drain.
4. Place the end of the oil drain hose into a suitable container.
5. Unscrew the oil drain plug and drain the engine oil.
6. Replace the oil drain plug.
7. Push the drain hose back into the bilge.
8. Replace the bilge plug and tighten firmly.

Always dispose of waste oil in accordance with local regulations.

Chapter 4: Controls & Gauges

Steering

- Your boat features a power-assisted rack-and-pinion steering system.
- For information about the power-assist fluid reservoir, refer to the engine operation and maintenance manual.
- Boat steering is *not* self-centering.
- Refer to the engine manual for more steering system details.

Shift/Throttle Controls

 WARNING!
<i>LOSS OF CONTROL HAZARD!</i>
Improper maintenance of the shift/throttle hardware may cause a sudden loss of control!

Read *all* of the information about the shift/throttle controls in the shift/throttle manual, the engine operation manual, and the *Sport Boat Owner's Manual*.

Power Trim & Tilt

- The stern drive on your boat is equipped with power trim and tilt.
- Trim and tilt instructions are provided in the engine operation manual and the shift/throttle manual.

Gauges

Cleaning the Gauges

 CAUTION
<i>PRODUCT or PROPERTY DAMAGE HAZARD!</i>
<ul style="list-style-type: none">• Use only mild soap and water to clean the gauge lenses and bezels.• Use of other cleaners, including common window cleaning solutions, may cause the lenses to crack.• Lenses cracked in this manner will NOT be covered by our warranty.

Gauge Fogging

- Moisture may occasionally find its way into the gauges causing lens fogging.
- Turning *On* the gauge lights will help dry the lenses.
- Fogging will not harm the gauges.

Radio Transmission Interference

VHF or other radio transmissions may cause brief erratic readings on the tachometer. This will not damage the tachometer gauge or affect its accuracy when not transmitting.

Fuel Gauge

It is normal for the pointer on your fuel gauge to bounce as fuel sloshes back and forth in the fuel tank.

Depth Finder(s) (If Equipped)

 WARNING!
<ul style="list-style-type: none">• Do NOT use the depth finder as a navigational aid to prevent collision, grounding, boat damage or personal injury.• When your boat is moving, submerged objects will NOT be seen until they are already under your boat.• Bottom depths may change too quickly to allow time for your boat to react.• If you suspect shallow water or submerged objects, run your boat at very slow speeds.

Chapter 5: Plumbing

Bilge Pumps

NOTICE

Discharge of oil, oil waste, or fuel into navigable waters is prohibited by law. Violators are subject to legal action by the local authorities.

- Your boat has two bilge pumps for pumping water out of the bilge.
- The autofloat switches, mounted next to the bilge pumps, will turn **On** the bilge pumps if bilge water rises above a preset level.
- You can also turn **On** the bilge pumps yourself using the switches at the helm.
- The bilge pumps are wired directly to the battery. Unless the battery is dead, the bilge pump system should work even when your boat is unattended.

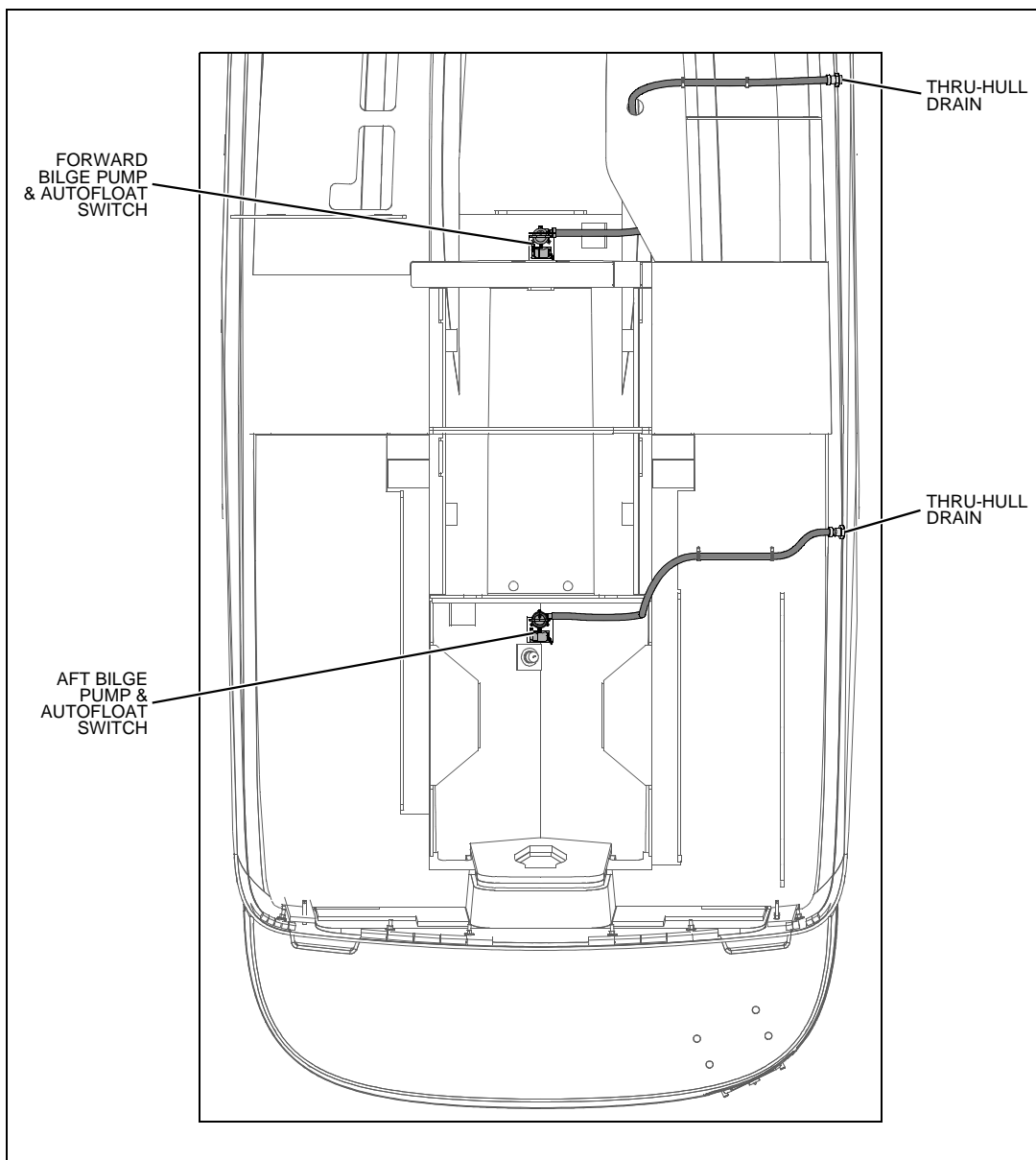

Bilge Pump Testing

- The bilge pumps are vital to the safety of your boat.
 - Test the bilge pumps often.
1. One at a time, turn **On** each bilge pump switch at the helm.
 2. Make sure that water in the bilge is pumped overboard.
- If there is water in the bilge and the pump motor is running but **not** pumping, inspect the discharge hose for a kink or collapsed area.
 - If the discharge hose looks okay, check the bilge pump housing for clogging debris (see below).

Checking for clogging debris:

1. Remove the pump motor from the housing:
 - a. Lift the tab while rotating the fins counter-clockwise.
 - b. Lift out the pump motor.
 - c. Clear the housing of debris.
2. Reinstall the pump motor:
 - a. Make sure the "O" ring is properly seated.
 - b. Coat the "O" ring with a light film of vegetable or mineral oil.
 - c. Align the cams on either side of the pump motor with the slots on the housing.

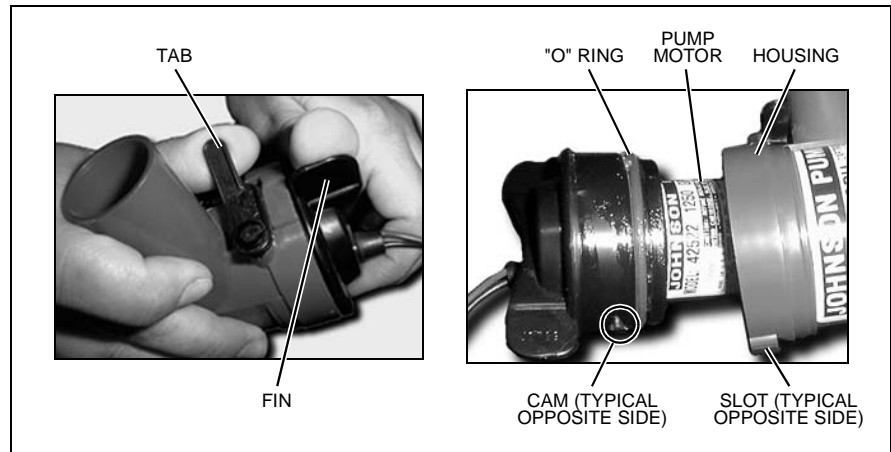

- d. Press the pump motor into the housing while twisting clockwise.
3. Check the reinstallation by trying to twist the fins counter-clockwise **without** lifting the tab; the pump motor should stay in place.

Autofloat Switches

- The autofloat switches turn the bilge pumps **On** when water rises above a preset level.
- Test each autofloat switch often.

Autofloat switch testing:

1. Lift the autofloat switch test button to turn **On** the bilge pump.
- If the pump does not turn **On**, check the fuse on the fuse block.
- If the fuse is good, but the switch still does not work, it may mean the switch is bad, or the battery is dead.
2. After testing, push the test button all the way **down** to reset auto mode.

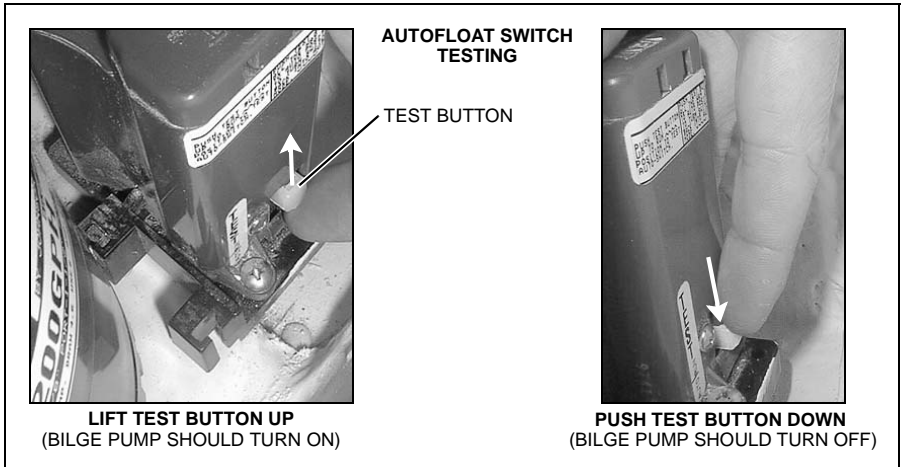

CAUTION

When the test is completed on each float switch, you **MUST** push the test button **ALL THE WAY DOWN** to reset auto mode!

Livewell System (If Equipped)

Seacocks

WARNING!

FLOODING and SWAMPING HAZARD!

- *Close* the seacocks before working on any part of the livewell system.
- *Close* the seacocks when leaving your boat unattended for any length of time.
- If a seacock is left open, a hose failure could flood the bilge, swamp the battery(s) and the engine, and even sink your boat.

CAUTION

SYSTEM DAMAGE HAZARD!

- *BEFORE* using the livewell system, make sure the intake and drain seacocks are *Open*.
- **Inspect and lubricate all seacocks annually.**

The livewell system features a water inlet seacock and a water drain seacock. When the livewell system is not in use *Close* the seacocks to prevent flooding:

- If the hose connected to the seacock fails, or;
- When working on equipment served by the seacock.

Before using the livewell system, make sure the seacocks are ***Open*** and stay ***Open*** until the system is shut ***Off***.

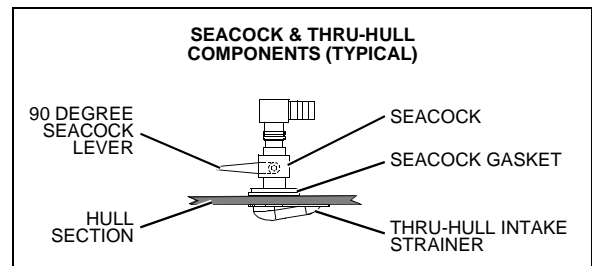

Filling & Using the Livewell



WARNING!

FLOODING and SWAMPING HAZARD!

- **NEVER** leave your boat unattended while the livewell system is running.
- Any leak or break in this system may pump large amounts of water into the bilge, which could swamp the battery(s) and the engine, and even sink your boat.



CAUTION

SYSTEM DAMAGE HAZARD!

- **BEFORE** using the livewell system, make sure the intake and drain seacocks are *Open*.
- Inspect and lubricate the seacocks annually.

1. **Open** the intake *and* drain seacocks.
 2. Insert the standpipe into the drain fitting at the bottom of the tank.
 3. On the switch panel, turn **On** the livewell pump switch (for the location of the livewell pump switch, see the *Component Locations* section in Chapter 2 of this supplement).
- Remove the standpipe to drain the livewell.

Troubleshooting

If you followed the instructions in steps 1 through 3 above, but water does **not** pump into the tank, possible causes are:

- The intake seacock is **Closed**.
- A hose is collapsed or there is clogging debris in the system.
- The livewell fuse is blown.

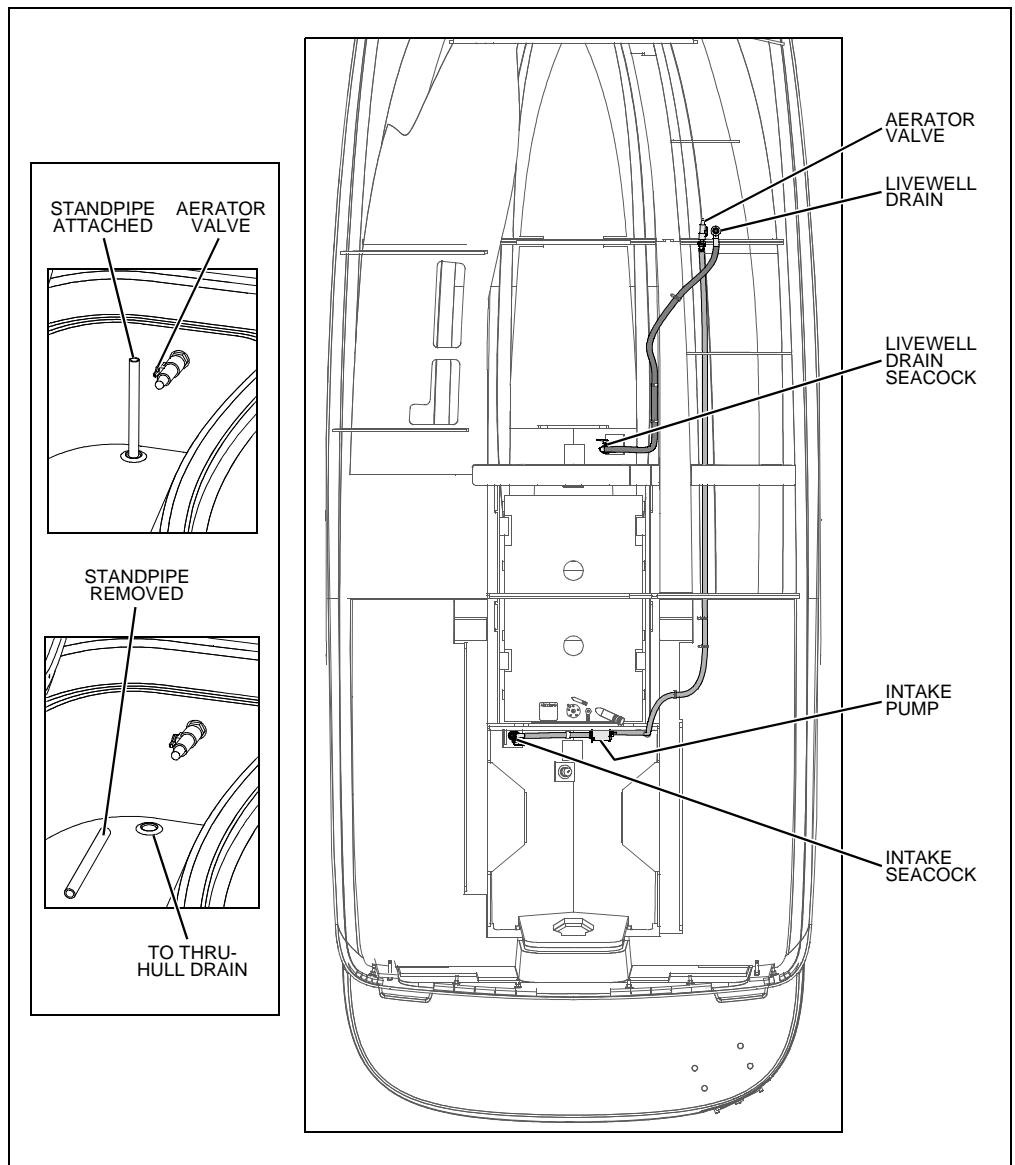

Freshwater System (If Equipped)

⚠ **WARNING!**

- **ONLY** use safe drinking (potable) water in your boat's freshwater system.
- **ONLY** use FDA approved "drinking water safe" hoses when filling the freshwater tank.
- **NEVER** use common garden hoses for drinking water.

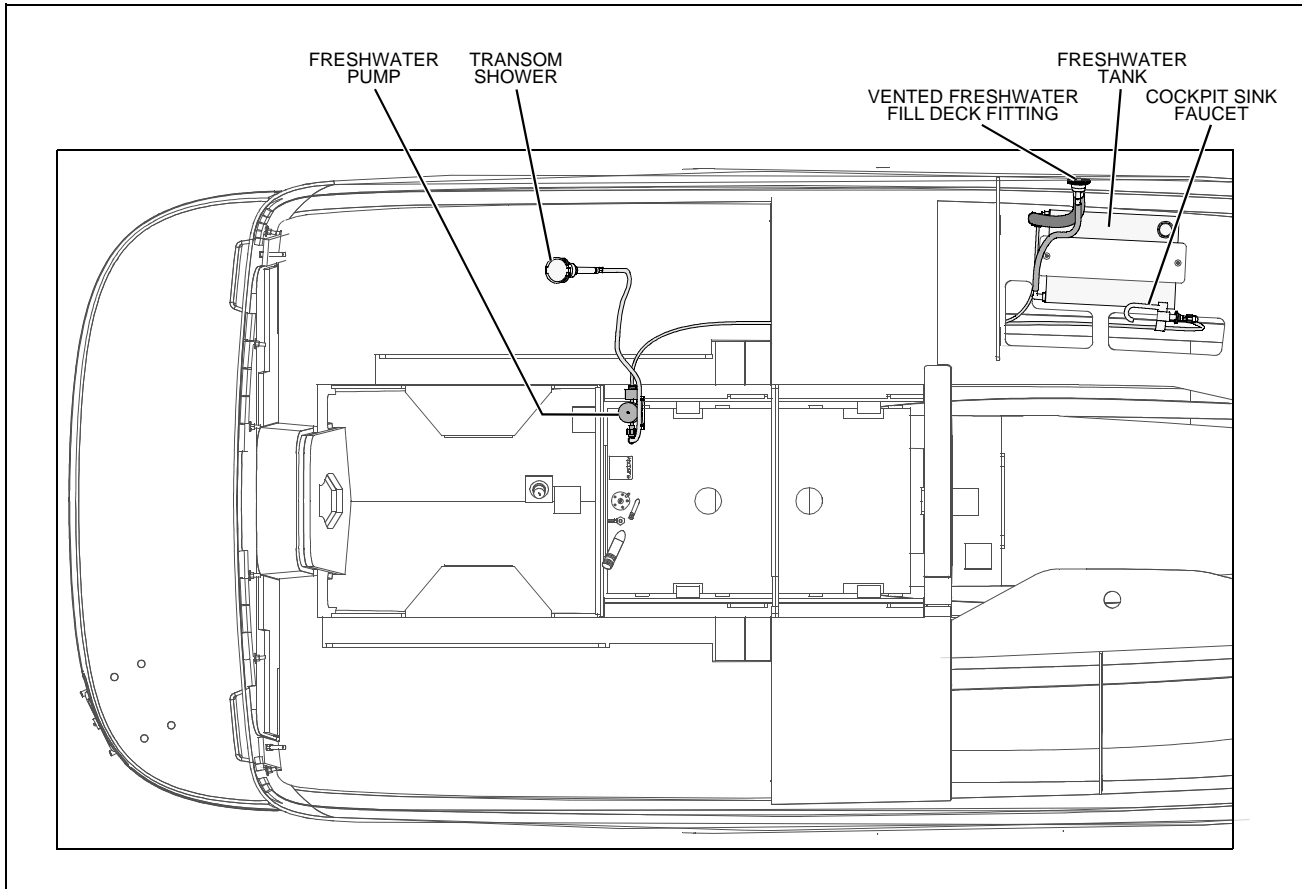

- Read the *Freshwater System* section in the *Sport Boat Owner's Manual*.
- The freshwater fill deck fitting is marked **WATER**.
- Pressurize the freshwater system by turning **On** the freshwater pump switch (the battery switch must also be **On**).
- For the location of the freshwater pump switch, see the *Component Locations* section in *Chapter 2* of this *supplement*.
- Turn **Off** the freshwater pump switch when your boat is **not** in use or when the freshwater tank is empty.
- Inspect and clean the freshwater filter often (the filter is located on the freshwater pump).
- If your boat is to be left unattended for a long period of time, pump the freshwater tank dry to prevent stored water from becoming stagnant and distasteful.
- If the freshwater system needs to be disinfected, ask your dealer about treatments available for your boat's system.

Transom Shower (If Equipped)

- Read the manufacturer's instructions **before** using the transom shower for the first time.
- The freshwater pump switch **must** be turned **On before** using the transom shower.

Freshwater System Winterization

1. Turn **On** the freshwater pump switch.
2. **Open all** of the faucets and showers and let the freshwater system drain completely.
3. Turn **Off** the freshwater pump switch.

All of the remaining water **must** be removed from the water lines. There are two ways to remove the remaining water from the lines:

- Compressed Air
- Gravity Draining

Compressed Air

CAUTION

FRESHWATER SYSTEM DAMAGE HAZARD!

- A faucet **MUST** be **Open** when compressed air is blown through the freshwater system.
- **NEVER** blow compressed air through the water system when **ALL** of the faucets are **Closed**.

You **must** have an air compressor with an air hose and an air nozzle.

1. Remove the water line from the outlet side of the freshwater pump (opposite side from filter).
2. **Open** the faucet that is furthest away from the freshwater pump.
3. Place the air nozzle against the end of the just removed water line and blow air through the system.
4. When water stops coming out of the faucet, stop the air and **Close** the faucet.
5. One at a time, repeat this process on **all** faucets and showers.

Gravity Draining

1. **Open all** faucets and showers.
2. Remove the drain plug from the tee fitting on the freshwater tank.
3. When the water has stopped draining from the freshwater tank and the water lines, replace the drain plug.

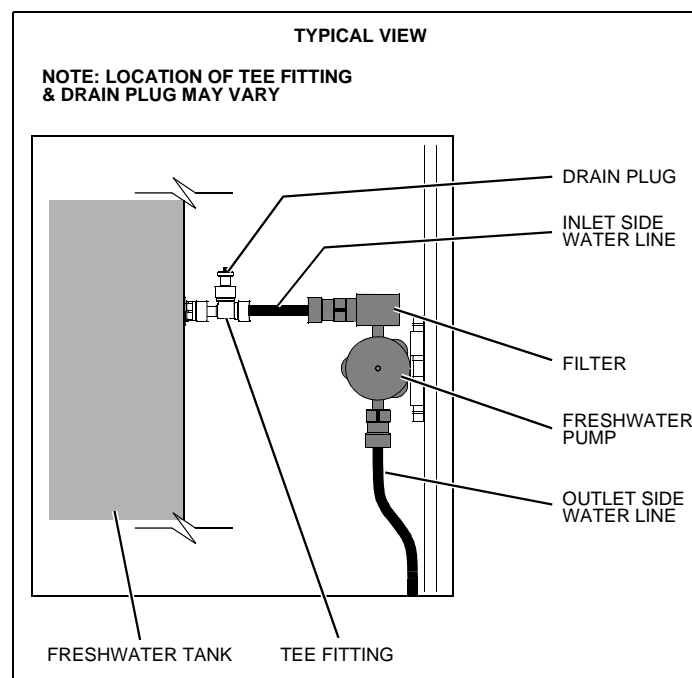

Drain Systems

Deck Drains

- Water on the deck is drained overboard through the deck drains.
- Keep the deck drains free of debris.

Sink Drain

The cockpit sink is above the waterline and are gravity drained overboard.

Portable Toilet

NOTICE
Check with local authorities for regulations regarding the legal use of marine head systems.

Read the manufacturer's operating instructions *before* using the portable toilet.

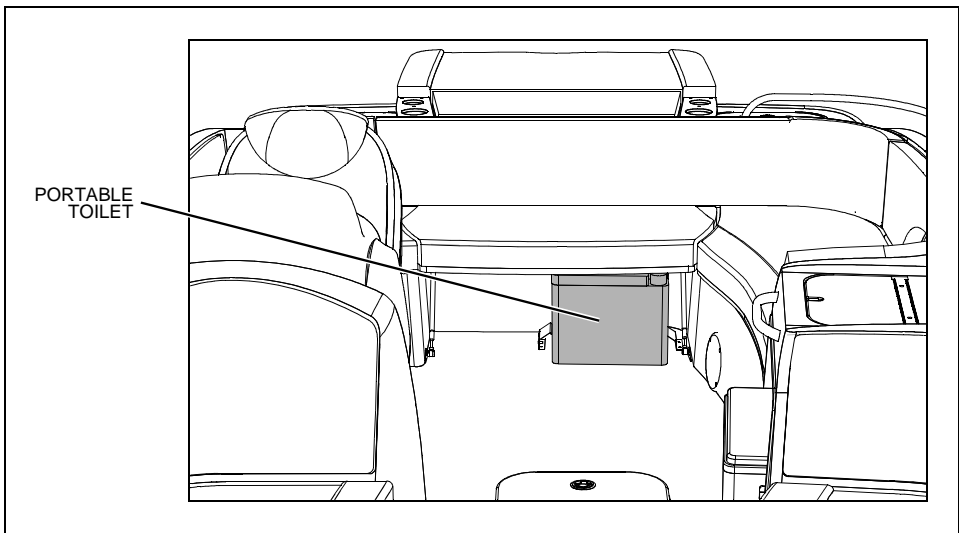

Chapter 6: Deck Equipment

Cleats & Bow/Stern Eyes

! WARNING!
PERSONAL INJURY and/or PRODUCT or PROPERTY DAMAGE HAZARD!
NEVER lift your boat using the bow/stern eyes or the cleats.

Read the section on towing in the *Sport Boat Owner's Manual* **before**:

- Towing anything behind your boat.
- Being towed by another vessel.

Bow Mount Trolling Motor (If Equipped)

Read the manufacturer's instruction manual **before** using the trolling motor.

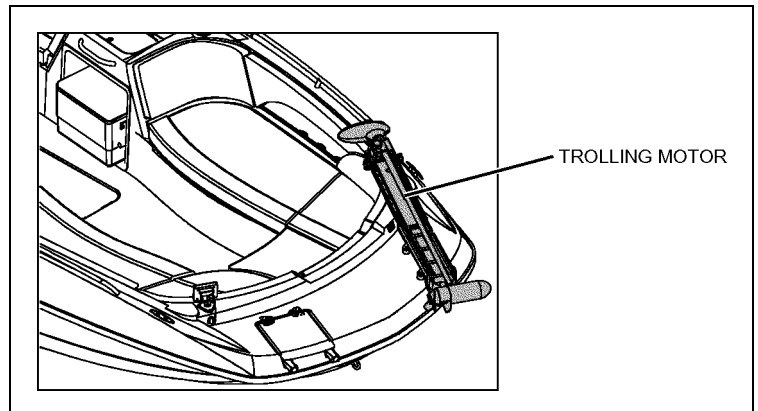

Ski-Tow Ring

! WARNING!
PERSONAL INJURY and/or PRODUCT or PROPERTY DAMAGE HAZARD!
Failure to follow these guidelines can result in injury or death:

- **ONLY** tow water skis, wakeboards, or recreational towables.
- Do **NOT** tow parasails, kites, or other boats.
- Do **NOT** tow more than two persons at one time.
- Use caution with skier in tow as tow rope may snap back into cockpit when released.

Attach the tow rope as shown in the photo.

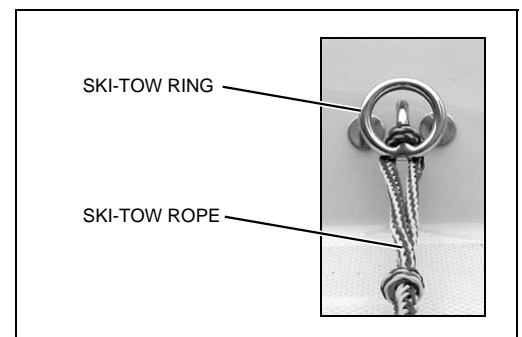

Ski-Tow Tower (If Equipped)



WARNING!

PERSONAL INJURY and/or PRODUCT or PROPERTY DAMAGE HAZARD!

Failure to follow these guidelines can result in injury or death:

- Read **ALL** warning labels on ski-tow tower.
- **BEFORE** each use, make sure **ALL** bolts are in place and tight.
- **ONLY** tow water skis, wakeboards, or recreational towables.
- Do **NOT** exceed the **MAXIMUM** tow weight of 600 pounds.
- Do **NOT** tow parasails, kites, or other boats.
- Do **NOT** tow more than two persons at one time.
- Do **NOT** climb on, sit on, stand on, jump off or dive off tower.
- **NEVER** allow passengers to sit behind tow rope attachment point.
- Use caution with skier in tow as tow rope may snap back into cockpit when released.
- **NEVER** allow loose tow rope ends to dangle off tower.
- When tower is up, watch for low obstacles such as tree limbs, bridges, or power lines.

Attaching the Ski-tow Rope

1. Place the ski-tow rope loop (A) over the ski-tow pylon (B).
2. Put a twist in the ski-tow rope loop (A) and place over the ski-tow pylon (B) again.

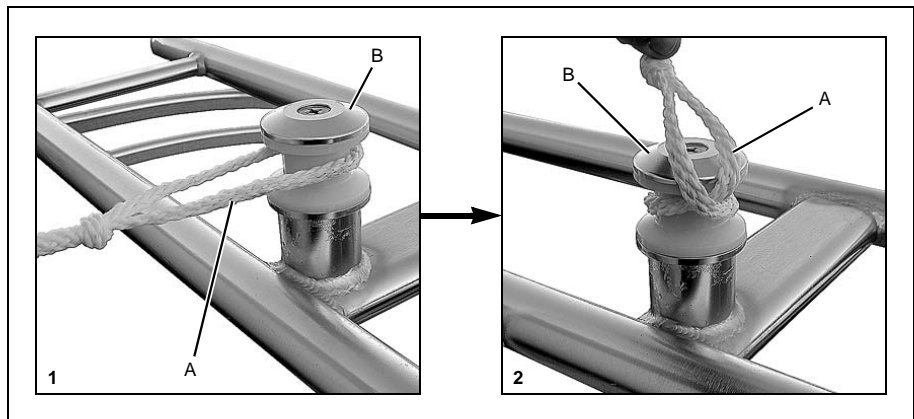

3. Pull ski-tow rope to tighten.

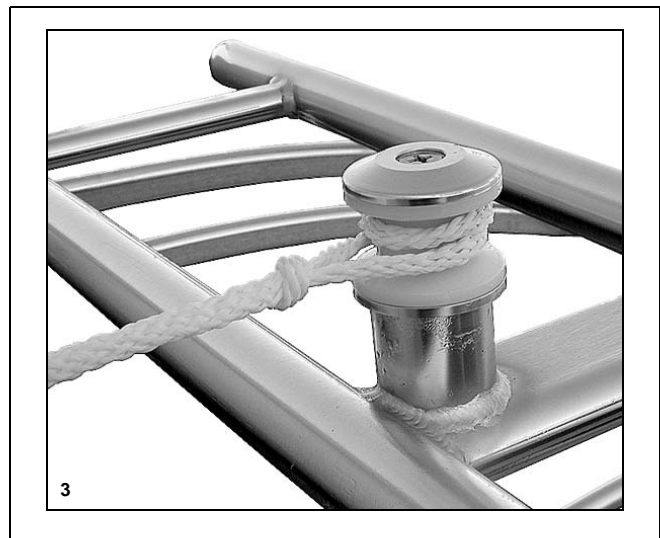

Folding the Ski-tow Tower



WARNING!

PERSONAL INJURY and/or PRODUCT or PROPERTY DAMAGE HAZARD!

- Folding or unfolding the ski-tow tower is a two person task.
- **BEFORE** each use of the folding ski-tow tower, make sure both lock-down bolts are tightened firmly.
- Read **ALL** warning labels on the ski-tow tower.

To fold the ski-tow tower into the storage position:

1. Remove the lock-down bolts (A) on each side of the tower.
 2. Carefully fold the tower aft.
 3. Replace the lock-down bolts on each side of the tower.
- To return the tower to the towing position, perform the above steps in reverse order.

Tower Care

Read the manufacturer's 'Care of Tower' card.

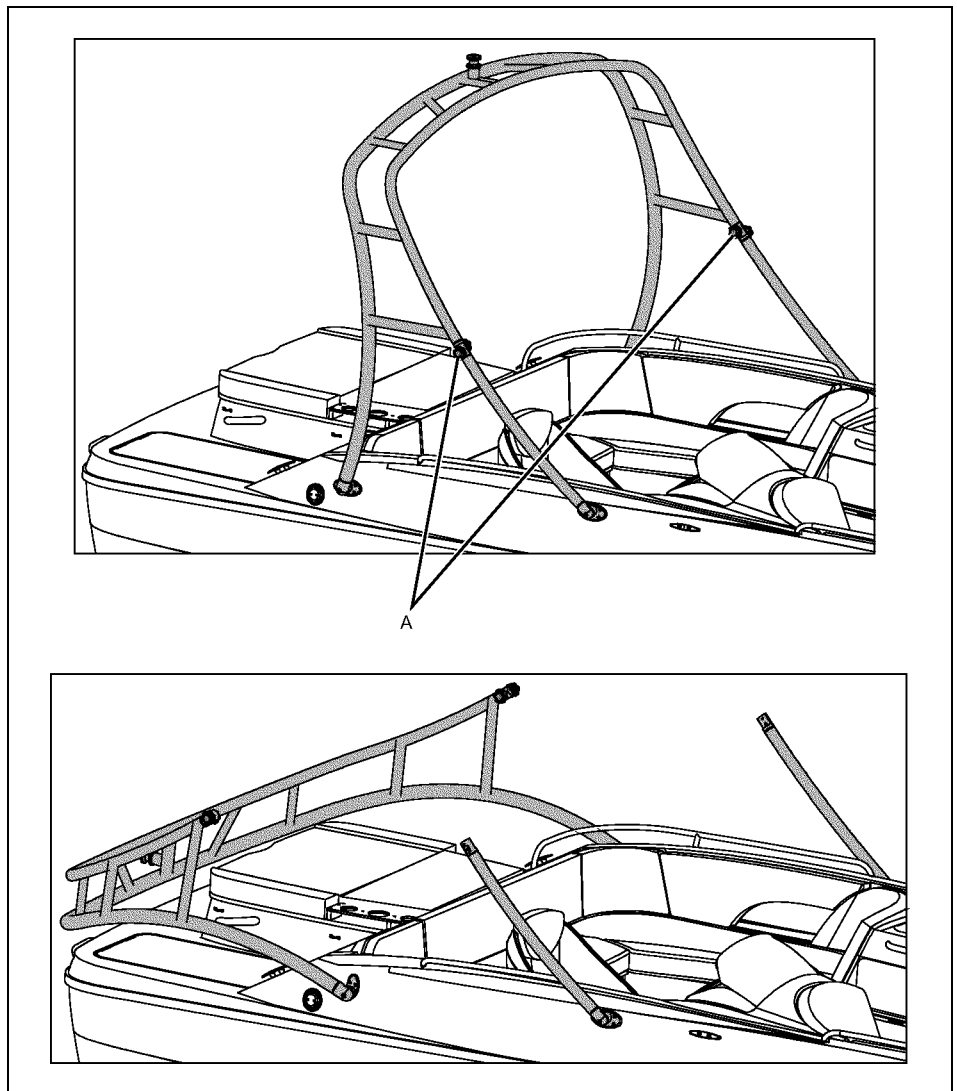

Canvas



CAUTION

PRODUCT or PROPERTY DAMAGE HAZARD!

Take down and securely stow *ALL* canvas & vinyl *BEFORE* your boat is transported by road.

NOTICE

BEFORE cleaning and/or stowing your canvas, read the *Canvas Care* section, later in this chapter.

NOTICE

Two people are needed for most of the tasks listed in this section.

NOTICE

Some canvas and vinyl options may not be described. Make sure your dealer explains how to install all canvas and vinyl.

Aft Bimini Top

1. Insert the end eyes of the main bow (A) into the deck hinges (B) and insert the securing pins.
 2. Insert the end eyes of the aft braces (C) into the deck hinges (D) and insert the securing pins.
 3. Insert the end eye of the port stern support (E) into the deck hinge (F) and insert the securing pin.
 4. Pull the secondary bow (G) and braces (H) forward.
 5. Insert the end eyes of the forward braces (H) into the deck hinges (I) and insert the securing pins.
- The jaw slides should not need to be adjusted.
 - If you decide to adjust the jaw slide positions, get the correct measurements from your selling dealer.

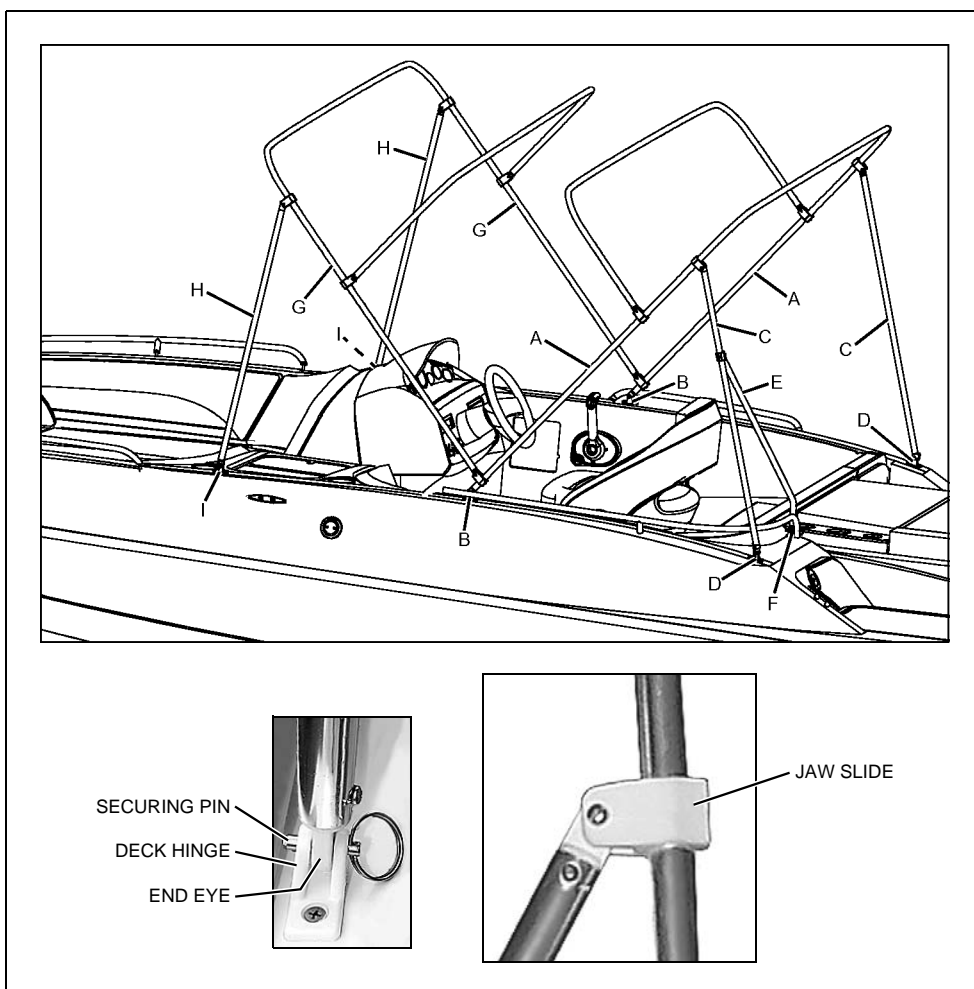

Forward Bimini Top (If Equipped)

1. Insert the end eyes of the main bow (A) into the deck hinges (B) and insert the securing pins.
 2. Insert the end eyes of the aft braces (C) into the deck hinges (D) and insert the securing pins.
 3. Pull the secondary bow (E) and braces (F) forward.
 4. Insert the end eyes of the forward braces (F) into the deck hinges (G) and insert the securing pins.
- The jaw slides should not need to be adjusted.
 - If you decide to adjust the jaw slide positions, get the correct measurements from your selling dealer.

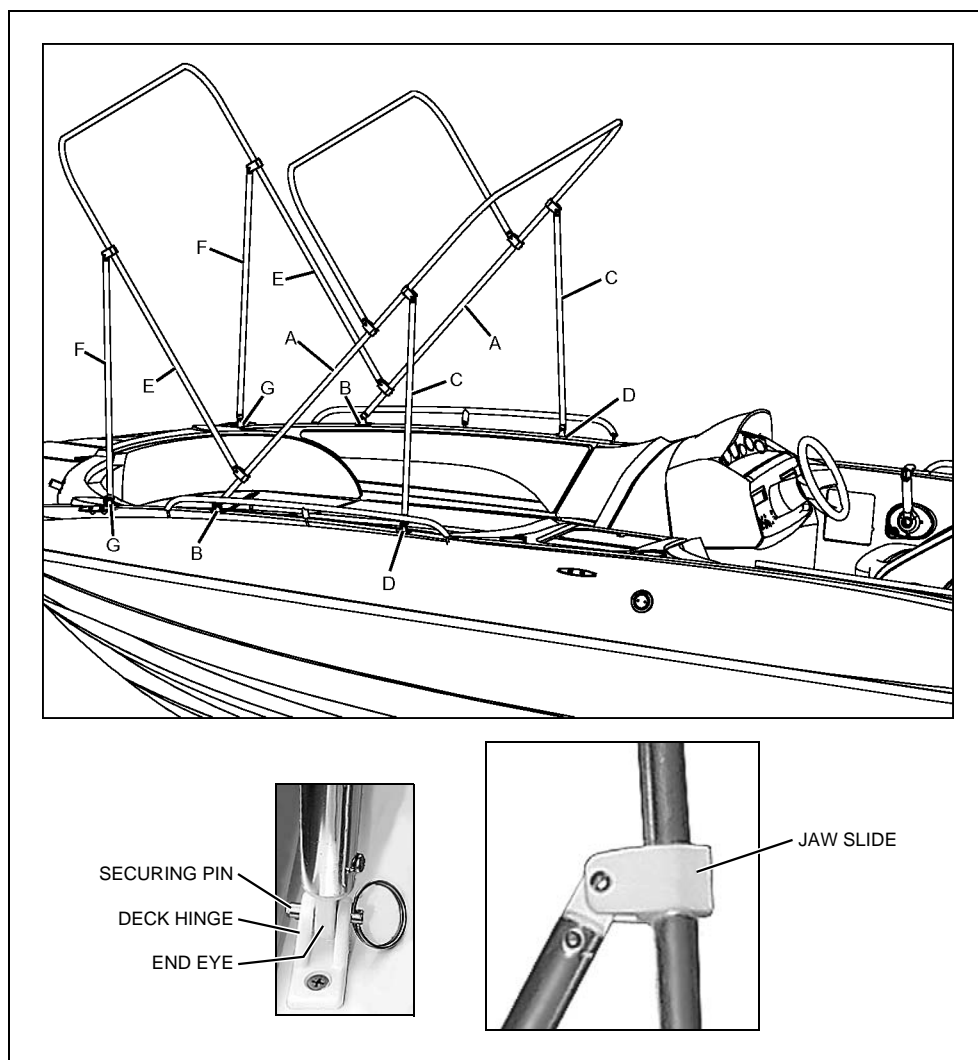

Canvas Care

- After each use, especially in saltwater, rinse the canvas with cold freshwater.
- **Before** stowing, let the canvas air-dry completely.
- The canvas can be rolled or folded for stowage.

Cleaning the Canvas

 CAUTION
<p>NEVER use detergents when washing the canvas. Detergents can destroy the water repellency, and mildew/UV resistant finish of your canvas.</p>

Regularly clean the canvas to prevent dirt, pollen, and etc. from embedding in the fabric. Generally, it is easiest to wash the canvas while it is installed on your boat.

- Use a soft-bristled brush to remove all dust and loose dirt.
1. Hose down the canvas with freshwater.
 2. Gently wash the canvas with a solution of lukewarm water (no more than 100° F) and non-detergent soap, such as Lux or Ivory Flakes.
 3. Rinse thoroughly to remove the soap.
 4. **Before** stowing, let the canvas dry completely.

Stubborn Stains

 CAUTION
<ul style="list-style-type: none"> • Soaking in bleach solutions may remove the waterproof finish of the fabric and may also decrease the life of the polyester thread used in the canvas. • If needed, a water repellent treatment should be reapplied to your canvas. Ask your dealer about the treatments available for your boat's canvas.

Some stubborn stains may resist normal washing and you can try the methods below. However, these methods may remove the waterproof finish of the fabric and may also decrease the life of the polyester thread used in the canvas. Reapply a water repellent treatment as needed.

Method 1

1. Add 1/8 cup (2 oz.) of **non-chlorine** bleach to one gallon of water and mix thoroughly.
2. Thoroughly wet the canvas and then gently scrub the stained area with the weak bleach solution.
3. Rinse with cold water to remove all of the solution.

Method 2

1. Add 1/2 cup (4 oz.) of **non-chlorine** bleach and 1/2 cup (4 oz.) Ivory Flakes to one gallon of water and mix thoroughly.
2. Soak the canvas in this solution for about 20 minutes.
3. Rinse with cold water to remove all of the solution.

Chapter 7: Entertainment Systems

Audio Equipment

NOTICE

AM radio reception may be impaired when the engine is running.
--

Read the manufacturer's instruction manual *before* using the audio equipment.

Chapter 8: Convertible Seats, Beds, & Tables

Bow Sunlounge Conversion

1. Remove the table (A) and the table leg (B).

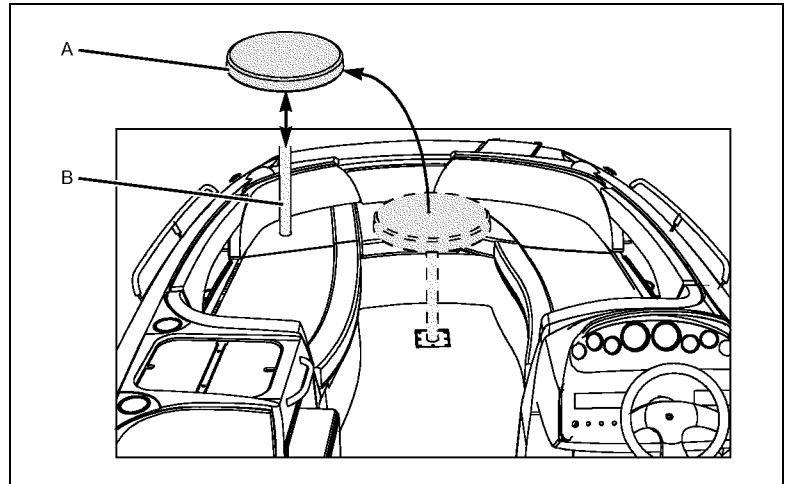

2. Securely store the table (A) and the table leg (B) in the storage area (C) under the engine hatch.

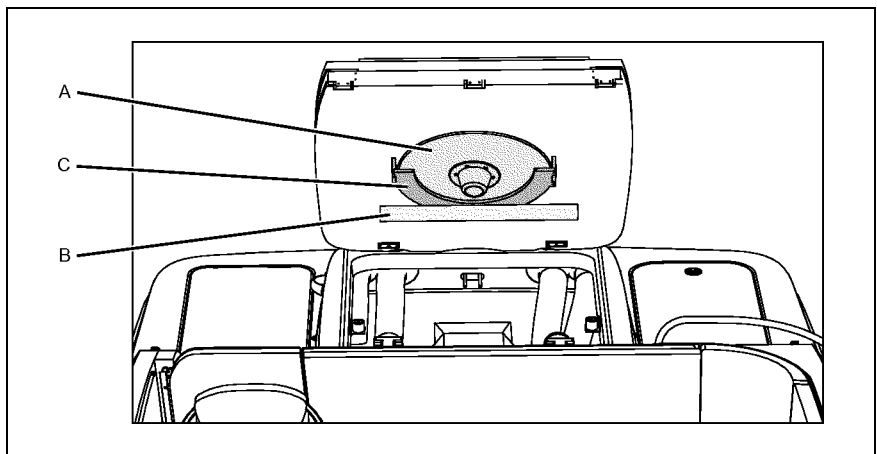

3. Unfold the support leg (D) of the forward filler board (E) and securely place the filler board on the recessed edges of the seat cushion bases.

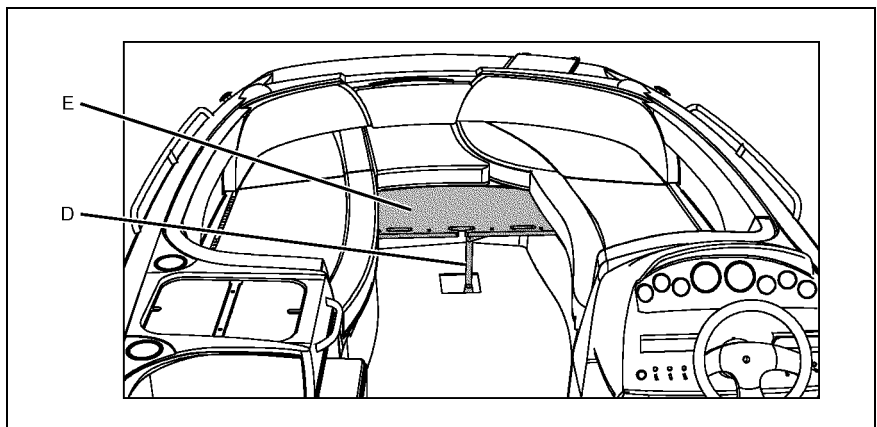

4. Unfold the support leg (F) of the middle filler board (G) and securely place the filler board on the recessed edges of the seat cushion bases.

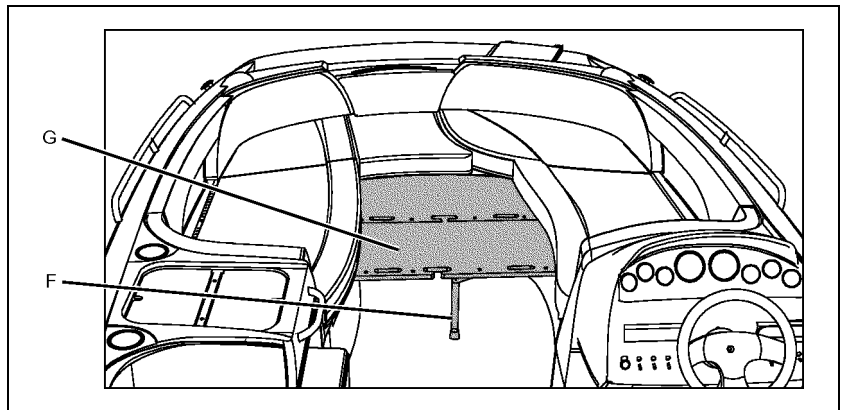

5. Unfold the support leg (H) of the aft filler board (I) and securely place the filler board on the recessed edges of the seat cushion bases.

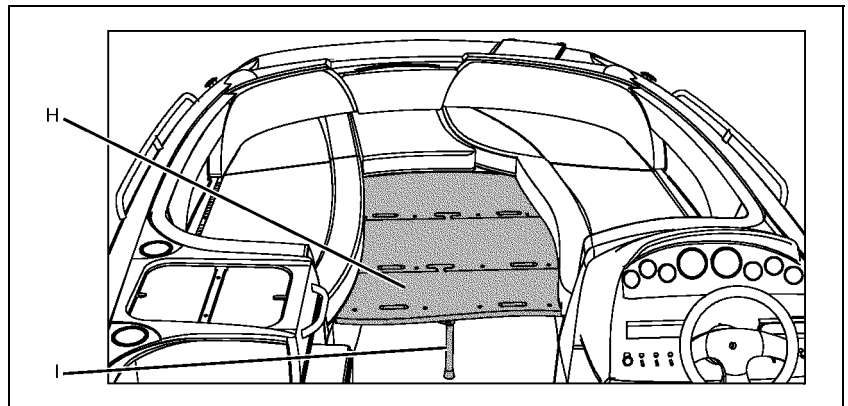

6. Place the filler cushions (J) on top of the filler boards.

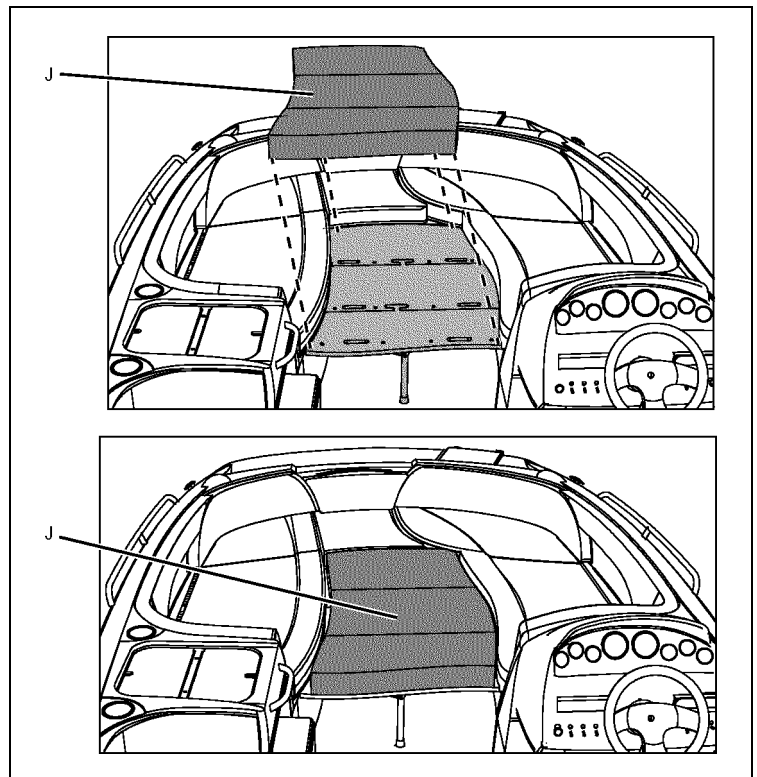

Removable Fishing Seats (If Equipped)

⚠ **DANGER!**



FALLING and ROTATING PROPELLER HAZARD!

- ***NEVER*** allow anyone to ride on parts of your boat ***NOT*** designed for such use.
- ***Sitting on a fishing seat while underway is especially hazardous and WILL cause personal injury or death.***

Remove and stow the fishing seats and pedestals in a safe and secure area **before** getting underway or trailering your boat.

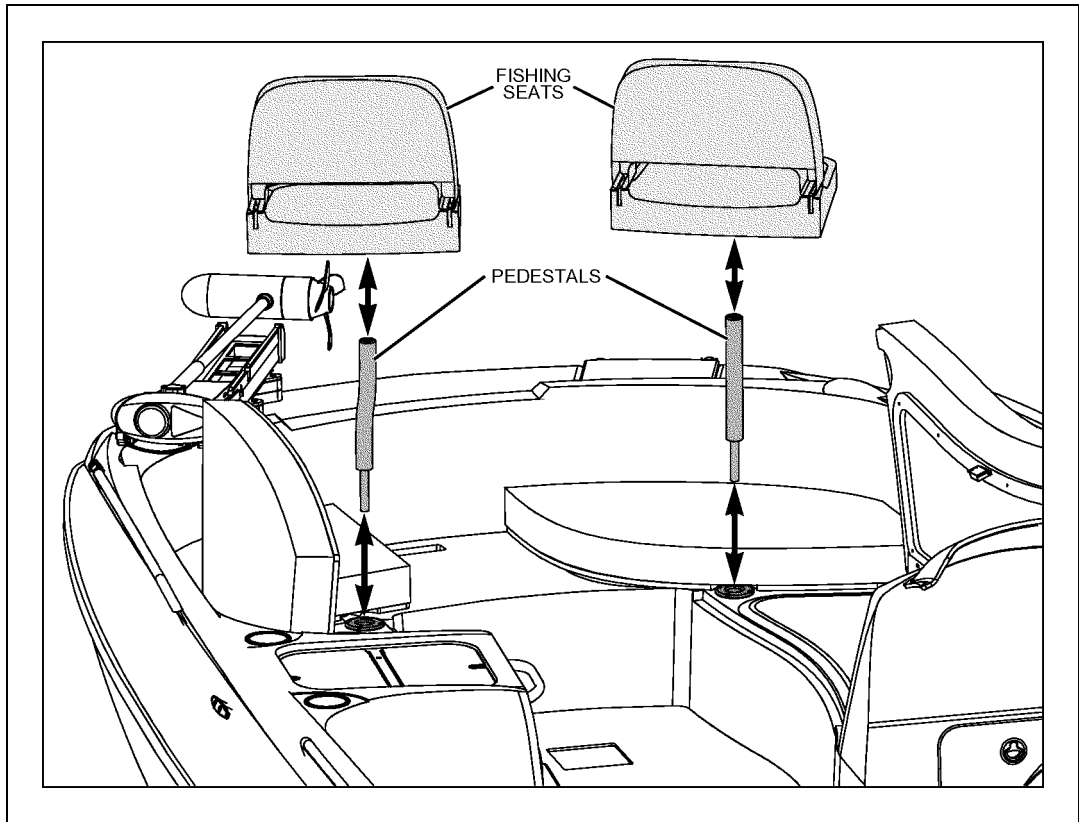

Chapter 9: Lights

Care & Maintenance

All of the lights installed on your boat are of top quality, but you should be aware that failure may periodically occur for a variety of reasons:

1. There may be a blown fuse - *replace the fuse.*
2. The bulb may be burned out - *carry spare bulbs for replacement.*
3. A wire may be damaged or may have come loose - *repair as required.*
4. The bulb base may be corroded - *clean the base and coat it with non-conductive electrical lubricant.*

Exterior Lights



CAUTION

- Be conservative in the use of battery power.
- Prolonged use of cabin interior lights (overnight) *WILL* result in a drained battery.

- The lights are powered by your boat's 12-volt DC system.
- The battery switch *must* be turned *On* for the lights to work.

Navigation Lights



CAUTION

Avoid the storage of gear where it would block navigation lights from view.



NOTICE

Running lights are legally required to show boat direction and right-of-way at night.

Chapter 10: Electrical System

DANGER!







EXTREME FIRE, SHOCK and EXPLOSION HAZARD!

- To minimize the risks of fire and explosion, *NEVER* install knife switches or other arcing devices in the fuel compartment.
- *NEVER* substitute automotive parts for marine parts. Marine electrical, ignition, and fuel system parts were designed and manufactured to comply with rules and regulations that minimize risks of fire and explosion.
- Do *NOT* modify the electrical systems or relevant drawings.
- Have qualified personnel install batteries and/or perform electrical system maintenance.



WARNING!

FIRE and EXPLOSION HAZARD!









Fuel vapors can explode! *BEFORE* electrical system maintenance or activation of electrical devices:

1. Check the bilge areas for fuel vapors or leaking fuel. If you see leaking fuel or smell fuel vapors:
 - a. Do *NOT* start the engine, do *NOT* turn *On* any electrical devices, extinguish *ALL* cigarettes, cigars, and other sources of flame or ignition.
 - b. Get everyone off your boat.
 - c. Get trained help to find and fix the problem.
2. Run the bilge blower(s) for at least four minutes prior to engine starting, electrical system maintenance, or activation of electrical devices.

CAUTION

SHOCK and ELECTRICAL SYSTEM DAMAGE HAZARD!



When the engine is running, *NEVER* turn *Off* the battery switch or disconnect the battery cables. Doing either could cause damage to your boat's engine and/or electrical system.

NOTICE

Electrical connections are prone to corrosion. To reduce corrosion-caused electrical problems:

- Keep *ALL* electrical connections clean.
- Apply a spray-on protectant that is designed to protect connections from corrosion.

12-Volt DC System

Battery

- The battery supplies electricity for lights, 12-volt accessories and engine starting.
- The *Electrical* section of *Chapter 8* in the *Sport Boat Owner's Manual* provides battery care and maintenance instructions.

Fuses

- Fuses for the engine and main accessory power are on the fuse block under the helm dash.
- Some equipment may have secondary fuse protection at the unit, or at the battery.

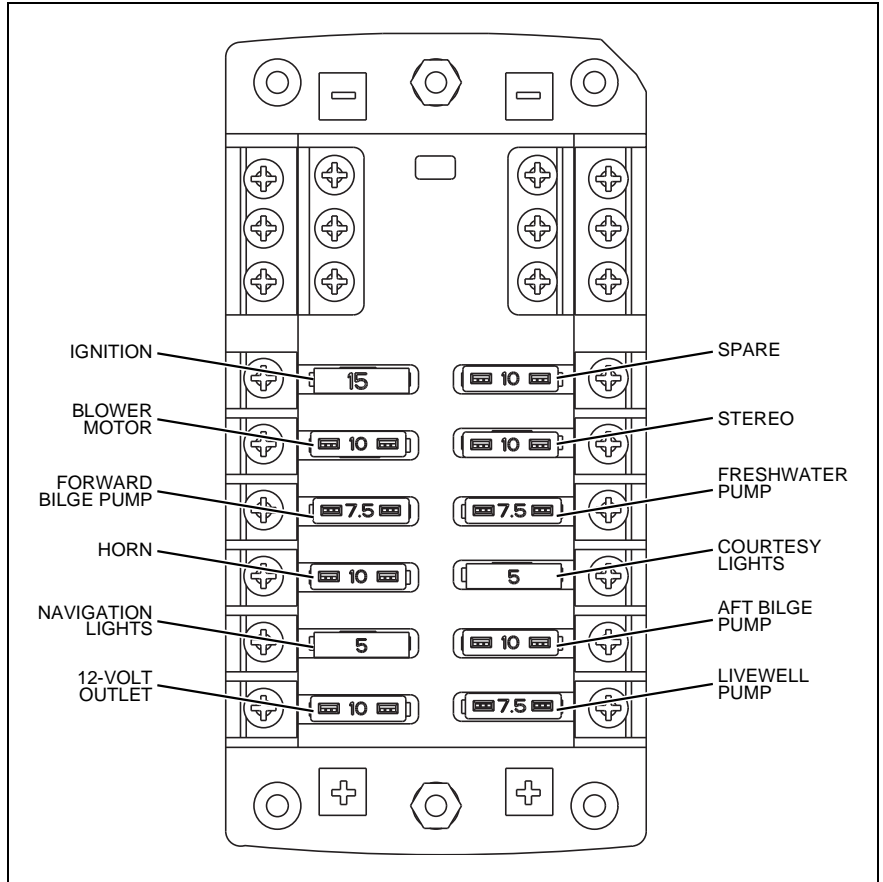

12-Volt DC Accessory Outlet

CAUTION

Do NOT use the 12-volt DC accessory outlet with a cigarette or cigar lighter. High temperatures may melt the outlet.

- The 12-volt DC accessory outlet can be used with any 12-volt device which draws 10-amps or less.
- The 12-volt DC accessory outlet is protected by a 10-amp fuse on the fuse block.
- For the location of the 12-volt DC accessory outlet, see the *Component Locations* section in *Chapter 2* of this supplement.

Alternator

The alternator will keep the battery properly charged when the engine is running at, or above, cruising speeds.

Electrical Routings

12-Volt DC Deck Harnesses

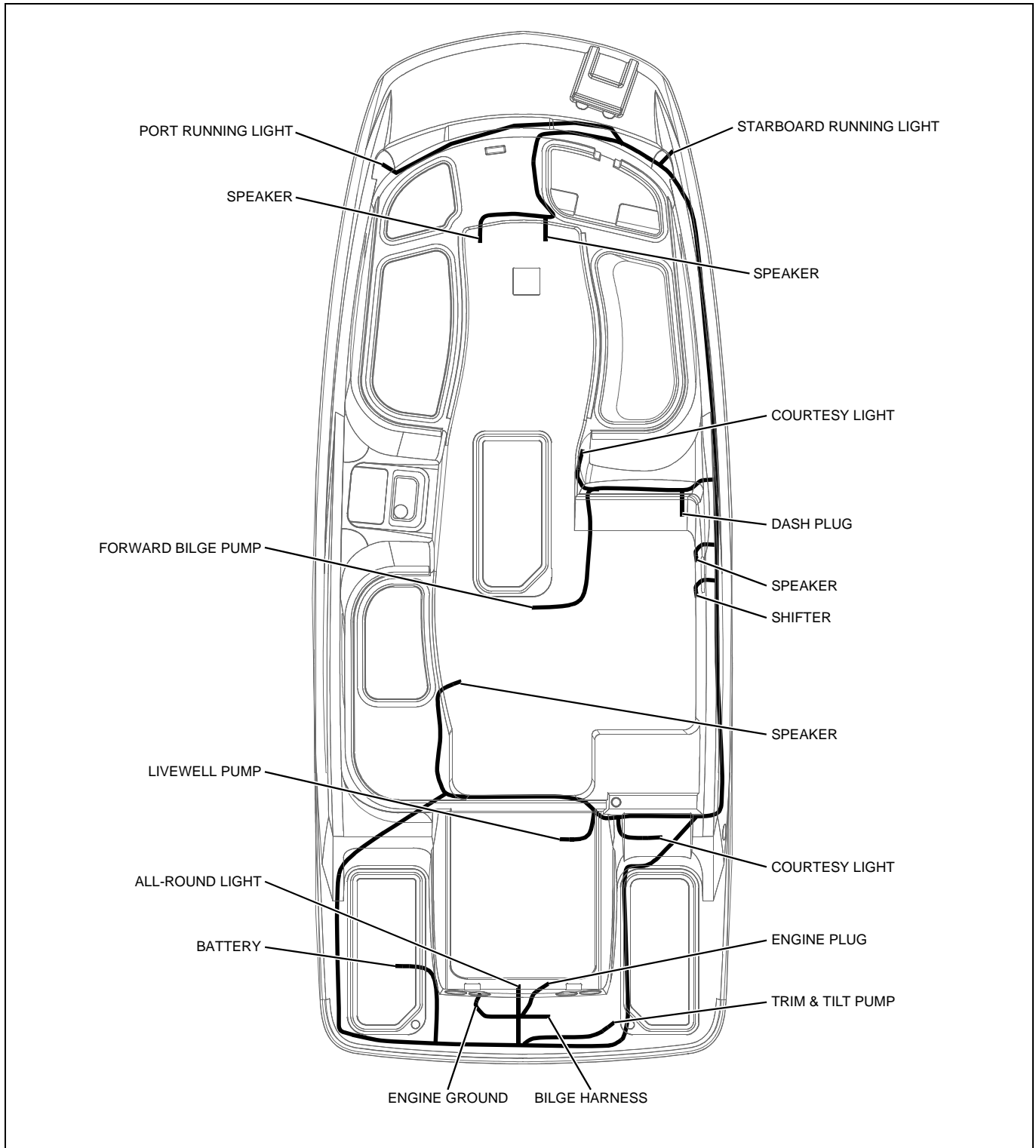

Battery Cable Routing

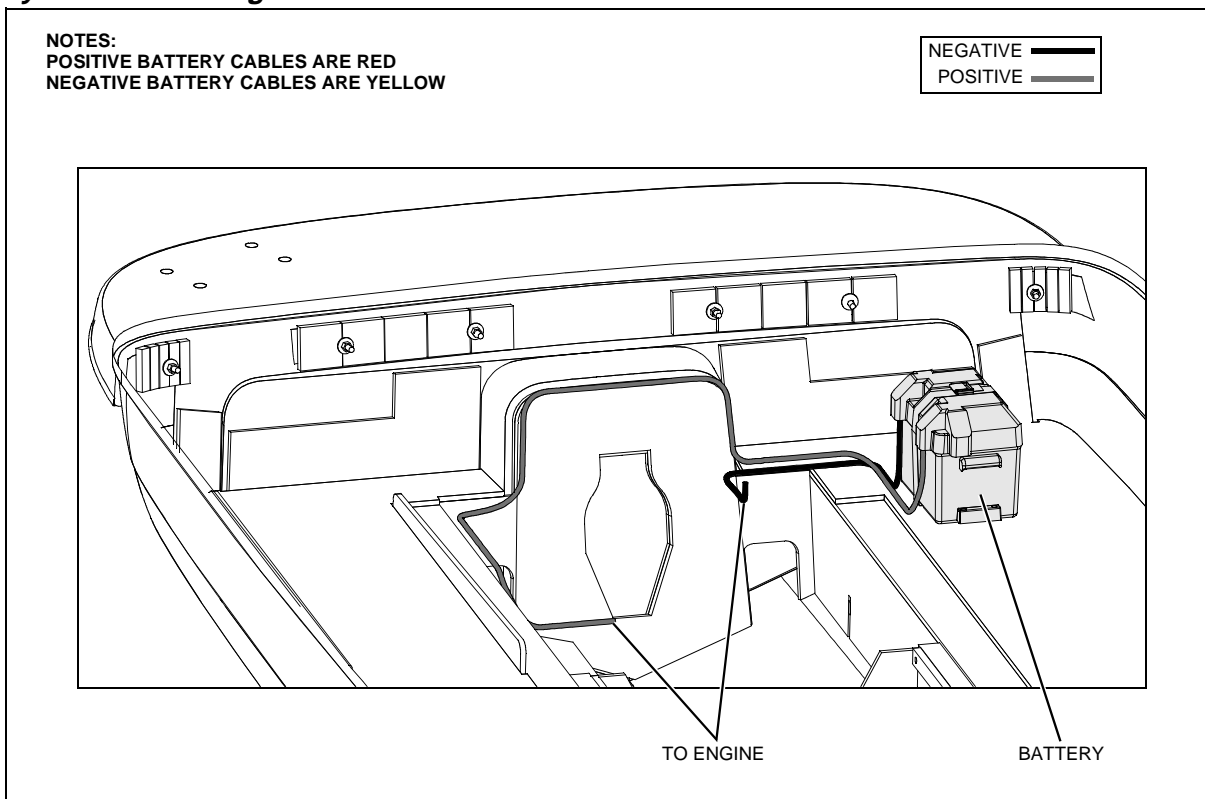

Wiring Diagram

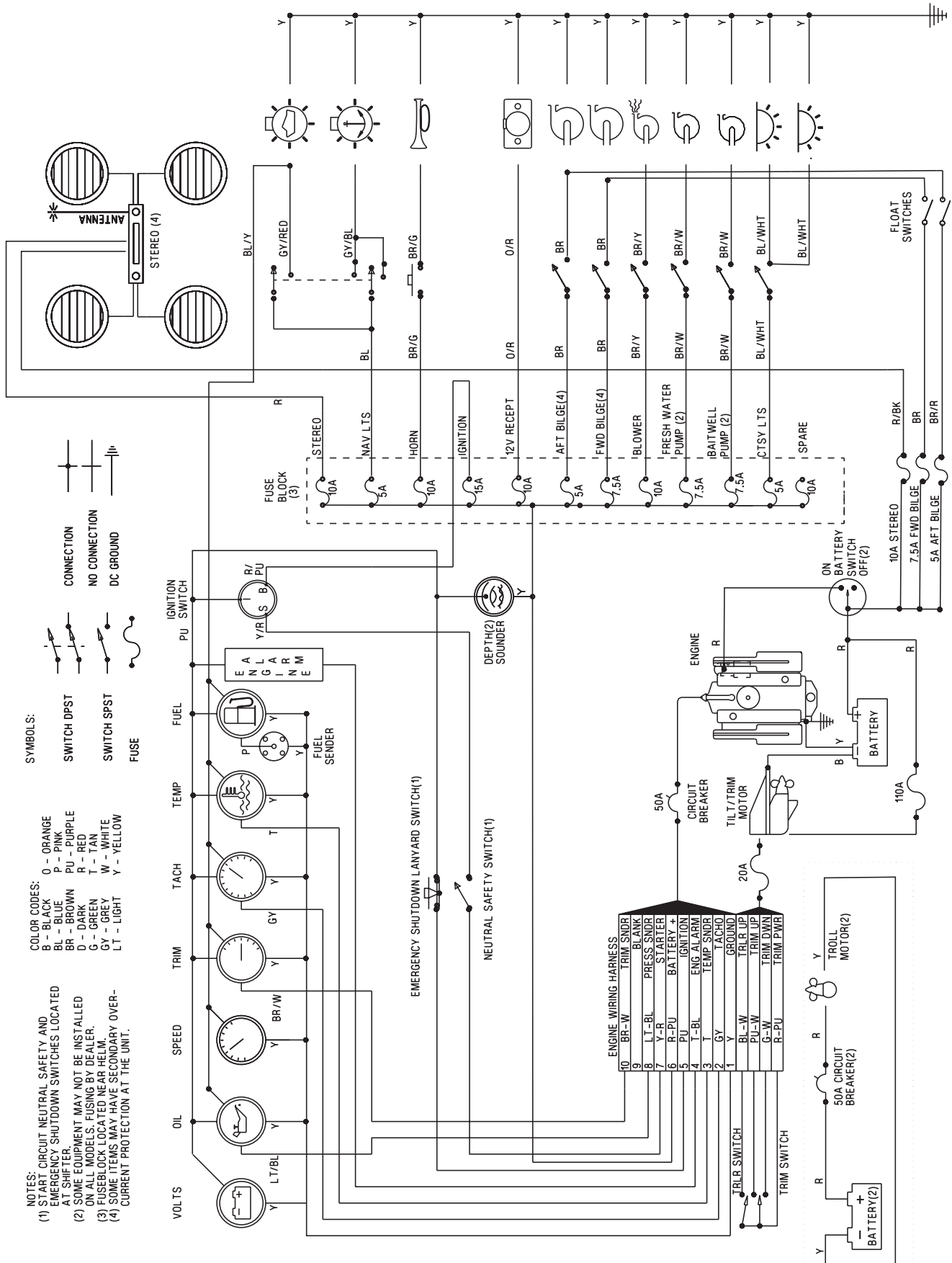

Important Records

Selling Dealer

Name Of Dealership

Address

Phone/FAX/E-mail

Sales Manager

Service Manager

Engine

Manufacturer

Model Name/Number

Engine Serial Number

Propeller

Manufacturer

Pitch

Model Number

Key Numbers

Ignition

Other

Electronics

Manufacturer

Model Name/Number

Serial Number

Manufacturer

Model Name/Number

Serial Number

Manufacturer

Model Name/Number

Serial Number

Manufacturer

Model Name/Number

Serial Number

Manufacturer

Model Name/Number

Serial Number

Float Plan

Before going boating, fill out a copy of this float plan (or similar) and leave it with a *reliable* person whom you can depend on to contact the Coast Guard or other rescue organization, if you do not return as scheduled.

Description of Boat

Registration/Documentation Number		
Length	Make	Type
Hull Color		Trim Color
Fuel Capacity	Engine Type	Number of Engines
Distinguishing Features		
Distinguishing Features		

Operator of Boat

Full Name		
Male or Female	Age	Health
Address		
Address		
Phone/FAX/E-mail		
Operator's Experience		

Persons Onboard

Full Name		
Age	Health	Phone Number
Full Name		
Age	Health	Phone Number
Full Name		
Age	Health	Phone Number
Full Name		
Age	Health	Phone Number
Full Name		
Age	Health	Phone Number

Survival Equipment

Marine Radio (Yes/No)	Type	Frequencies
Number of PFDs	Flares (Yes/No)	Mirror (Yes/No)
Smoke Signals (Yes/No)	Flashlight (Yes/No)	Food (Yes/No)
Water (Yes/No)	Anchor (Yes/No)	Raft/Dinghy (Yes/No)
Paddles (Yes/No)	EPIRB (Yes/No)	Other
Other	Other	Other

Vehicle Description

Make	Model
Color	License Number
Where is the Vehicle Parked?	

Trip Expectations

Departing From	
Departure Date	Departure Time
Stopover 1	
Arrive No Later Than: Date	Arrive No Later Than: Time
Stopover 2	
Arrive No Later Than: Date	Arrive No Later Than: Time
Stopover 3	
Arrive No Later Than: Date	Arrive No Later Than: Time
Stopover 4	
Arrive No Later Than: Date	Arrive No Later Than: Time
Stopover 5	
Arrive No Later Than: Date	Arrive No Later Than: Time
Stopover 6	
Arrive No Later Than: Date	Arrive No Later Than: Time
Final Destination Port (If Different Than Home Port)	
Arrive No Later Than: Date	Arrive No Later Than: Time

If not returned by the date and time listed above, call the Coast Guard or other local authority.

Coast Guard Phone Number
Local Authority Phone Number

Part Number 1818981

Bayliner • P.O. Box 9029 • Everett, WA 98206 • 360-435-5571