

B A Y L I N E R

---

---

# OWNER'S MANUAL

BASS TROPHY



---

---

THE WORLD'S NUMBER ONE PLEASURE BOAT BUILDER!

# Welcome Aboard

---

This manual has been prepared to assist you in the operation and care of your Bayliner boat. Although it is somewhat general in scope, familiarization with its contents can contribute to the more effective operation of your boat.

Understanding your new boat and how it works is essential to your boating enjoyment and safety. We recommend that you perform the following steps:

1. Make certain that you receive a full explanation of all systems from the dealer before taking delivery of your boat.
2. Read this manual thoroughly, paying particular attention to the subjects of **fueling, checking for fumes, starting, carbon monoxide, loading limits, recommendations for safety, and warranty.**
3. Practice—all members of the family should be familiar with the operation and systems of your boat.
4. Participate in a safe boating course. Call the local office of the United States Power Squadrons or the United States Coast Guard Auxiliary for the date and location of their next class.

There is information in this manual related to the following **Bayliner boats:**

---

1510 Bass Trophy  
1710 Fish-N-Ski  
1710 Bass Trophy  
1810 Fish-N-Ski  
1810 Bass Trophy

Due to our ongoing commitment to product improvement, we reserve the right to change, without notice or other obligation, the specifications or other information contained in this publication.

**WARNING! A qualified operator should be in control of the boat at all times. Do not operate the boat while under the influence of alcohol or drugs. Never operate the boat at speeds which exceed your ability to react if an emergency develops. At night, turn on the appropriate running lights and cruise at a reduced speed that allows you plenty of time to avoid dangerous situations.**

# Table of Contents

---

## **PREPARATION**

Recommendations for Safety	4
Safety Equipment	6
Tool Chest	7
Miscellaneous Items	7
Static Float Attitude	7
Other Tips	8

## **TRAILERING**

8

## **OPERATING**

Fueling Procedures	10
Fuel Capacity Table	11
Launching	11
Starting	11
Before You Leave	12
Maneuvering	13
Boat Performance	16
Boat Running Attitude	16
Instruments	16

## **COMPONENTS/SYSTEMS**

Electrical System	17
Fuel Systems	18
Starter Motor	19
Bilge Pump	19
Running Lights	19
Livewells	20
Electric Trolling Motor	20
Ski Tow Posts	20
Pedestal Seats	21

## **GENERAL MAINTENANCE AND REPAIRS**

Bilges/Engine	21
Cabin and Topside Areas	22
Hull	23

## **STORAGE**

25

## **NAUTICAL TERMS**

27

## **WIRING DIAGRAMS**

28

## **WARRANTY**

30

## **PREPARATION**

---

Prior to leaving on your first outing (or, for that matter, any outing) there are certain items to check and activities to perform. Familiarize yourself with your boat while dockside, and consider the following:

### **Recommendations for Safety**

---

1. **Personal Flotation Devices:**

One Coast Guard approved personal flotation device (PFD) of suitable size is required for each person aboard a recreational boat. New PFDs bearing Coast Guard approval are now identified as Types I, II, III, or IV.

Requirements for boats sixteen feet (16') or over in length: One (1) Type I, II, or III (wearable) PFD for each person on board, and one (1) Type IV (throwable) PFD in each boat.

Requirements for boats less than sixteen feet (16') in length: One (1) Type I, II, III, or IV PFD for each person on board.

2. Always have children wear PFDs. Always check those devices intended for young children for fit and performance in the water. Never hesitate to have "all hands" wear lifesaving devices whenever circumstances cause the slightest doubt about safety.
3. Do not overload or improperly load your boat. Maintain adequate freeboard at all times. Consider the sea conditions, the duration of the trip, the weather and the experience of the personnel on board. Do not permit persons to ride on parts of the boat that were not designed for such use. Sitting up on seat backs, bow riding, gunwale riding, or lounging on forward sundeck cushions while underway can be especially hazardous.
4. Falls are the greatest cause of injury both afloat and ashore. Eliminate tripping hazards where possible, make conspicuous those that must remain, and require that all persons on board wear proper footwear.
5. Understand the meanings of navigation buoys, and never moor to one. (It is a Federal offense.)
6. Know the various distress signals. A recognized distress signal used on small boats is to slowly and repeatedly raise and lower the arms outstretched to each side.

7. Storm signals are for your information and safety. Learn them and be guided accordingly.
8. A special flag (red flag with white diagonal stripe) flown from a boat or buoy means skin diving operations. Approach with caution and stay clear by at least 25 yards.
9. Be especially careful when operating in any area where there might be swimmers.
10. Watch your wake. It might capsize a small craft. You are responsible for damage caused by your wake. Pass through anchorages at a minimum speed.
11. Learn and abide by common boating "rules of the road".
12. Always have up-to-date charts of your cruising area on board.
13. Keep an alert lookout. Serious accidents have resulted from failure in this respect.
14. Always instruct at least one person on board in the rudiments of boat handling in case you are disabled or fall overboard.
15. Consider what action you would take under various emergency conditions such as a person overboard, fog, fire, a damaged hull or other bad leaks, motor breakdown, severe storm or collision.
16. If you ever capsize, remember that if the boat continues to float it is usually best to remain with it. You are more easily located by a search plane or boat.
17. Keep firefighting and lifesaving equipment in good condition and readily available at all times.
18. Do not test fire extinguishers by squirting small amounts of the agent. The extinguisher might not work when needed. Always follow approved instructions when checking fire extinguishers.
19. Have an adequate anchor and sufficient line (at least six times depth of water) to assure a secure hold in all types of weather and sea conditions.
20. Boat hooks are valuable when docking or when needed to retrieve objects that have fallen overboard.

21. Keep electrical equipment and wiring in good condition. No knife switches or other arcing devices should be installed in fuel compartments. Allow ample ventilation around batteries.
22. Good housekeeping in your boat is important. Cleanliness diminishes the probability of fire.
23. Know your fuel tank capacity and cruising range. If it is necessary to carry additional fuel, do so only in proper containers. Take special precautions to prevent the accumulation of fuel vapors in confined spaces.
24. Before departing on a boat trip, advise a responsible friend or relative about where you intend to cruise. Be sure to give that person a good description of your boat. Keep them advised of any changes in your cruise plans. These precautions will enable your friend or relative to tell the Coast Guard where to search for you and what type of boat to look for if you fail to return. Be sure to advise the same person when you complete your trip to prevent any false alarms about your safety.
25. Your local United States Coast Guard Auxiliary and the United States Power Squadrons offer safe boating classes several times a year. These are comprehensive and generally of minimal cost to you. Call your local U.S. Coast Guard Auxiliary or Power Squadron Flotilla for the time and place of the next class.

## **Safety Equipment**

---

The following safety related items should be considered as part of your standard equipment:

1. Fire extinguishers (located for easy access)
2. Personal flotation devices
3. Fenders, lines and boat hook
4. Flares (night and day type)
5. Flashlight
6. Charts of intended cruising area
7. First aid kit

## **Tool Chest**

---

1. Assorted screwdrivers (Phillips and flat blade)
2. Pliers (regular, vise-grip, and water pump)
3. Wrenches (box, open-end, allen, and adjustable)
4. Socket set (metric and U.S. standard)
5. Hacksaw with spare blades
6. Hammer
7. Battery jumper cables
8. Electrical tape
9. Assorted fasteners
10. Gear grease and penetrating oil
11. Feeler gauges

## **Miscellaneous Items**

---

1. Engine and accessories manual
2. Propeller with fastening devices
3. V-belts
4. Engine lubricating oil
5. Fuel and oil filters
6. Cooling pump impellers
7. Fuel can
8. Light bulbs
9. Spare set of spark plugs and other ignition parts

## **Static Float Attitude**

---

The static attitude of your boat can be affected by many variables. Optional equipment and loading of gear are the biggest contributors to a boat's list. After launching, the floating attitude of any new boat can be adjusted. If your boat lists to one side, store heavy items on the light side and light items on the heavy side.



## **Other Tips**

---

1. When commissioning a new boat, do not plan an extensive trip or party until you have a shakedown cruise to make sure all equipment on your boat is functioning properly and you are familiar with its operation.
2. Use big fenders or fender boards to protect your boat's hull whenever mooring next to floats, piers, or other boats.
3. Carry adequate line properly sized to your boat. We suggest at least two 30' lengths of 3/8" nylon line.

## **TRAILERING**

---

An Escort trailer, specifically designed for your Bayliner boat, should be used for trailering your boat. Use of any other trailer requires careful checking to insure that capacity and support points are correct.

1. Before using your trailer, read the trailer owner's manual thoroughly.
2. Check brakes for proper operation prior to departure on each trip. (Consult your state laws for trailer brake requirements and equip your trailer accordingly.)
3. Frequently check wheel lug nuts for security.
4. Check tires for proper inflation. Underinflated tires heat up rapidly and tire damage is likely to occur.
5. Wheel bearings should be checked at least every 90 days and before putting your boat away for the season.
6. Make it a habit to check the wheel hubs every time you stop for gas or refreshments. If the hub feels abnormally hot, the bearings should be inspected before continuing.
7. On extended trips, carry spare wheel bearings, seals and races.
8. Check to be sure the taillights and turn signals work when attached to the towing vehicle. Some automobiles require heavy duty flasher units to make turn signals work properly.

9. Check springs and undercarriage for loose parts.
10. Your boat should be fastened to the trailer by a line from the bow eye to the winch, PLUS a safety chain or cable from the bow eye to the winch stand or trailer tongue. The stern of your boat should be tied down to the trailer from the stern eyes.
11. Too much or too little tongue weight will cause difficult steering and tow vehicle sway. A rough rule of thumb is 5% to 10% of boat and trailer weight on the tongue.
12. Close and secure all cabin windows and doors. Store equipment so that it cannot slide or fall.
13. Before towing, take down the convertible top, side curtains and back cover. **Convertible tops are not designed to stay on boats at highway speeds.**
14. Carry a spare wheel and tire, including tools needed to change them.
15. Before backing your trailer into water, disconnect the light plug from the car. This will greatly reduce the chance of blowing out your trailer lights when they become submerged.

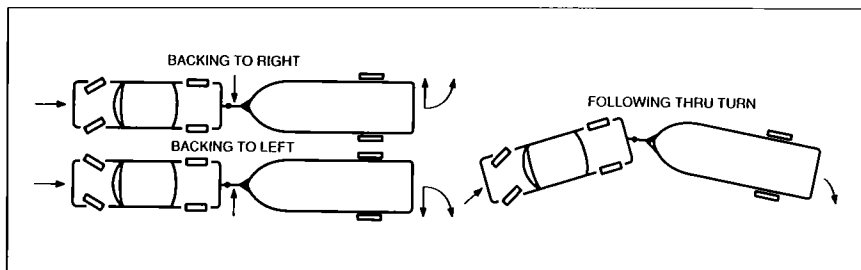

## **PRACTICE—PRACTICE—PRACTICE**

Before attempting that first launch, tow your boat to a nearby empty parking lot and practice backing. When backing, be sure to have a lookout to help direct you.

Make sure your outboard or outdrive unit is raised to clear obstacles. If not already so equipped, consider installing a right side mirror on your tow vehicle.

When rounding sharp turns, remember to swing wide to avoid cutting the corner with the trailer.

# OPERATING

---

## Fueling Procedures

---

**WARNING! Fuel vapors are explosive and can become trapped in the lower portions of a boat. While fueling, all doors, hatches, and portlights must be closed.**

**WARNING! Do not use fuels that incorporate any form of alcohol or alcohol derivatives. Alcohol destroys marine fuel system hoses and components, which could cause hazardous leaks, fire or explosion.**

### Internal “Built-In” Fuel Tanks

---

1. If on the water, be sure that your boat is securely moored to the dock.
2. Turn off all equipment including engines, appliances, bilge blower, lights, etc.
3. Extinguish all cigarettes, cigars or other items that may produce a spark or flame.
4. Close all openings including hatches, windows, doors, and portlights.
5. Through-deck fittings are provided for fuel tank filling. Remove the cap and insert fuel supply nozzle, allowing the nozzle to maintain contact with the fitting—thereby preventing possible static sparking.
6. Allow for thermal expansion on very hot days. Do not fill the fuel tank completely.
7. If, when filling the tank, you can't put fuel in at a reasonable rate, check the fuel vent line to see that it's not kinked or plugged.
8. Replace the fill cap and wash off any fuel spillage.
9. Inspect the bilge, visually and by smell, for fuel fumes or leakage. Any sign of fuel leakage, or any indication of fumes must be investigated and corrected prior to starting engine.

## Portable Fuel Tanks

---

1. Remove tanks from the boat for filling.
2. Follow instructions in the engine manual for the proper ratio and type of lubricating oil to be mixed with gas.
3. Before placing the tank in the boat, wash off any spilled fuel.
4. Note—some portable tanks have vent screws which must be open during engine operation.

---

### FUEL CAPACITY TABLE

---

Model	Tank Capacity (Gallons)
1510 Bass Trophy	Portable
1710 Fish-N-Ski	24
1710 Bass Trophy	24
1810 Fish-N-Ski	24
1810 Bass Trophy	24

## Launching

---

1. Your Bayliner powerboat is equipped with a transom drain plug. Make sure this plug is tightly in place.

**WARNING! Failure to install the drain plug securely will result in the boat filling with water when it is launched.**

2. Once in the water, immediately board your boat and inspect the lower compartments for signs of leakage.
3. If any leaks are noted, the boat should be removed from the water. The selling dealer should be notified so the leaks may be repaired before relaunching the boat.

## Starting

---

The engine operating and maintenance manual furnished with your boat describes prestart and starting procedures. The following notes are basic reminders, and are not intended to cover every detail of starting. We urge you to thoroughly read and understand your engine manual.

1. Check lubricating and cooling fluid levels.
2. Visually check for fuel, oil, coolant, and exhaust leaks.
3. Make sure the emergency engine shutdown switch cap is in place and the lanyard is attached to the operator.

**WARNING! A serious accident may occur if the emergency engine shutoff switch lanyard is not fastened to the boat operator. In order for the emergency engine shutdown system to operate correctly, the lanyard must be physically attached to the operator (around the wrist or securely fastened to a stout piece of clothing, such as a belt, etc.).**

**WARNING! Gasoline vapors are highly explosive. To prevent explosion and fire, check engine and fuel compartments before each use for fumes or accumulation of fuel.**

4. **Do not** continuously operate the starter for more than 15 seconds at a time. Allow at least three minutes for cooling between start attempts.
5. On boats so equipped, check voltmeter and temperature gauges immediately after the engine starts.
6. Check steering operation by turning the steering wheel full port and starboard while observing the outboard or outdrive movement.
7. While the boat is still securely moored to the dock, advance the shift control to forward, to reverse, and into neutral to check shifting operation.

**WARNING: Carbon monoxide is a poisonous gas that is colorless, odorless and heavier than air. Idling at the dock for long periods of time, or running your boat without adequate ventilation can result in dangerous accumulations of carbon monoxide gas inside the boat. Always ventilate the boat when operating the engine.**

## **Before You Leave**

---

Provided you have not encountered any problems, you are almost ready to go. (If you did encounter problems, **do not** attempt to operate your boat until they are corrected.) Before you leave, perform the following steps:

1. Check the operation of equipment such as bilge pumps, running lights, wipers, etc.
2. Instruct passengers in the use and location of flotation devices and fire extinguishers.
3. Obtain a reliable weather forecast and plan accordingly for comfort and safety.
4. Notify a responsible friend, relative, marine operator, or the Coast Guard of your cruise plans. Upon your return or a change in your cruise schedule, notify that person in order to avoid unnecessary concern.

## **Maneuvering**

---

With all your predeparture checks now completed, you are ready to leave the dock.

### **Basic Maneuvering**

---

Remember that all boats steer by the stern (the feeling is much like steering your automobile in reverse). For example, when you turn the steering wheel to the left, the stern of the boat will swing to the right as the boat goes into a left turn. This is especially important to keep in mind when docking and operating in close quarters with other boats.

There are no brakes on a boat. Stopping is accomplished by allowing the boat to slow down (under 5 mph) and then putting the engine in reverse. Gently increasing reverse power will allow you to stop the boat in a very short distance. A boat does not respond to steering in reverse nearly as well as it does when going forward, so do not expect to accomplish tight turning maneuvers when backing up.

Once you are away from the dock, devote some time to learning how to maneuver.

- Practice docking by using an imaginary dock.
- Practice stopping.
- When operating in close quarters or docking, all maneuvering should be done at idle speed. Proceed with caution in congested areas.
- Gradually increase your speed. Get used to the boat before any full throttle operation.

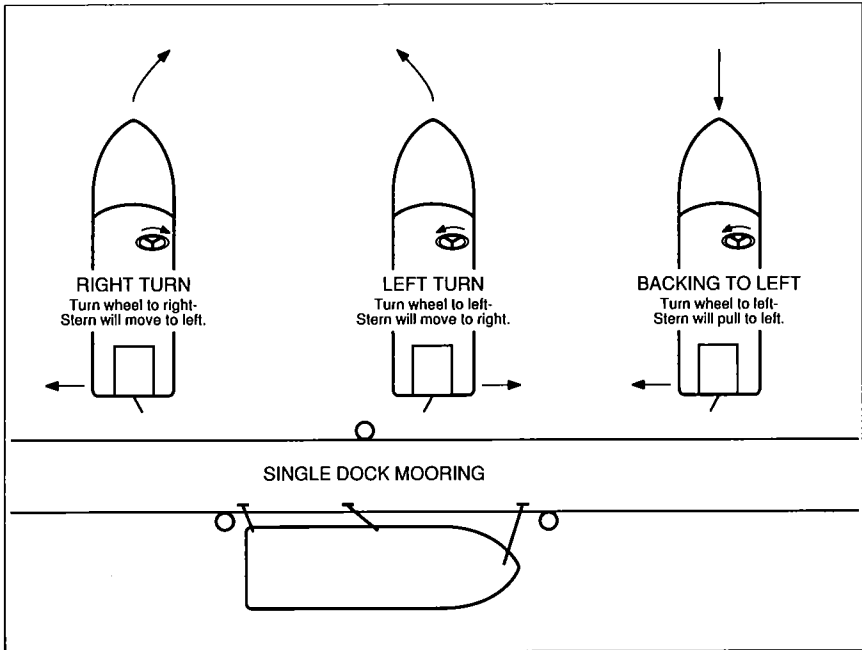

## Docking

### *Preparation:*

Proper docking requires preparation. Start by making sure you have adequate equipment, and that it is stowed correctly and ready for use. Your dealer is the best source for the amount and type of equipment you should carry.

### *Approaching the Dock:*

When approaching a mooring area, lower your speed within a reasonable distance to allow your wake to subside before it reaches other boats or docks. As you get close to your moorage, check for any wind or current action that may affect your maneuver; then make a conservative approach with these factors in mind. Try to use the elements to your advantage. Allow them to carry the boat into the dock. If there are high winds or strong currents, it is best to approach the moorage from the lee side. With a mild current or little or no wind it is best to approach from the windward side. When approaching, check to see that all lines are attached to the cleats on the side that you will be mooring and that fenders are lowered on that side. Be sure to check that the fenders are hung at the proper height.

As you approach your moorage, it is desirable to have one person at the bow and one at the stern of the boat, each with a boat hook and a mooring line attached to a cleat. Approach at idle RPM at an angle

approximately 45 degrees to the dock. When the bow is within a few feet of the dock (starboard side), the stern can be brought alongside the moorage by turning hard to port. Next, turn to starboard and at idle RPM put the boat into reverse. This will stop the boat and bring the stern even closer to the dock. These steps are reversed for docking to port.

### *Mooring:*

Attach lines to deck cleats by making a loop in one end that is large enough to pass through the hole in the base of cleat; then pass the loop back over the entire cleat. The line can now be used to secure your boat. Lines may be kept this way while running as long as they are coiled and cannot become fouled in deck gear or props. In heavy sea conditions, all lines should be removed from decks.

**TIP:** Tie up by running the line from the boat around the dock cleat and back to the boat. This way you can untie without jumping from deck to dock and back aboard. Just cast off one end and then bring the whole line on board.

**WARNING! Whenever you are towing another boat, or having your boat towed, make sure the towline is fastened securely to the bow or transom towing eyes only. Never attach a towline to deck cleats or the anchor windlass (if so equipped), as serious injury may result if the cleats or windlass pull free from the deck. Also, to reduce the danger created by a potential failure of the towline, all persons should stay well clear of the towline attach points on both the towing and the towed boats.**

### *Leaving the Dock:*

Take into account wind, tide, current, and other forces that affect your maneuvering as you leave the dock. Most maneuvering to and from a dock is best accomplished at idle speeds.

Do not forget to release mooring lines and stow fenders.

When leaving a moorage on your starboard side and your bow cannot be pushed away from the dock first, start forward with the steering wheel turned to starboard for two or three feet. Then shift to reverse with steering full to port. Repeat if necessary to get the stern far enough away from the dock so you can back clear of any other boats that may be moored ahead of you. (Reverse steering wheel directions when leaving a dock located to port.)



## Boat Performance

---

Boat speeds are effected by a great many factors. Some, such as temperature and altitude, you cannot change, but some factors you can:

1. **Loading:** Take only necessary equipment with you. Keep weight low in the boat and balanced.
2. **Propeller:** Keep it in good repair and at the correct pitch for your particular situation. The factory standard equipment propeller may not be the best for your particular boat and load conditions. If the engine RPM at full throttle is less than its maximum rating, try a prop of less pitch. If the engine RPM exceeds the maximum rating, try a prop of greater pitch.

A slightly bent or nicked propeller will adversely affect the performance of your boat.

3. **Weeds, barnacles and other growth:** Keep your boat bottom clean. When your boat starts "growing grass" it will slow down greatly.

## Boat Running Attitude

---

1. If your boat runs with its bow too high at cruising speeds, the following suggestions will help you lower the bow:
  - Move weight forward in the boat.
  - Adjust thrust angle of engine (reduce distance between bottom of transom and drive unit). See your engine owner's manual for instructions.
2. If your boat runs with its bow too low at cruising speeds (usually indicated by water coming off the hull far forward and steering difficulty or veering off course), you can raise the bow by performing the opposite of above.

## Instruments

---

While under way, instruments should be checked frequently for possible indications of trouble.

1. **Tachometer**—A tachometer is an electrical instrument that indicates engine revolutions per minute (RPM). The tachometer is useful for monitoring engine speed to avoid exceeding the maximum RPM

rating. In addition, it can be used to detect performance changes by comparing speedometer readings at various RPMs.

2. *Voltmeter*—Models 1710 and 1810 have two voltmeters, one at the forward electrical panel for the electric trolling battery, and another on the dash indicating the voltage of the main engine start battery. See “Electrical Systems” for proper voltage readings under a variety of conditions.
3. *Fuel Gauge*—The fuel gauge indicates fuel level. Since boats are exposed to rough water conditions and varying trim, fuel gauges may provide inaccurate readings at times. It is always good to keep track of your running time as a double check against an inaccurate gauge.

## COMPONENTS/SYSTEMS

---

### Electrical Systems

---

**WARNING! To reduce the risk of electric shock, only qualified personnel should install batteries and perform electrical system maintenance. You can minimize the danger of fire and explosion by not exposing the batteries to open flame or sparks. It is also important that no one smoke anywhere near the batteries.**

Although Bayliner manufactures many different models of powerboats, the electrical systems on all models operate on the same basic theory:

1. *Battery:*  
The key to a good marine electrical system is the battery (the batteries are a dealer-installed item). Bayliner makes the following recommendations on battery rating:

Outboard Models—minimum 70 amp/hour rating

On some models the condition of the battery can be read on the voltmeter when the ignition is in the ON position.

With the engine not running, voltmeter readings in the 11.5 to 12.5-volt range are considered normal. Readings in the 10 to 11.5-volt range indicate a marginal charge condition. Readings below 10 volts indicate a serious discharge condition.

With the engine running (over 1500 rpm) voltmeter readings of 13 to 14 volts are considered normal. Readings below this indicate a severely discharged battery or a nonfunctioning charging system.

**Check the battery water level regularly** by removing the caps. If the zinc plates are exposed, add distilled water. Corroded terminals can impair battery performance and charging ability. Clean them with baking soda and water, and coat them with a preservative or a light film of grease. Be sure all battery connections are tight. When storing the boat, it is best to remove the battery, give it a full charge, and store it inside away from extreme temperatures.

The adapter plug included with your electric trolling motor is designed for battery charging; it fits the receptacle on the forward electrical panel. Your Bayliner dealer can recommend a battery charger that is appropriate for whatever capacity battery you choose. Note that this plug is to be attached to a DC battery charger only, and is not to be used with standard household electric power.

2. *Fuses:*

Power Tilt motors are protected by a 20-amp fuse.

Fuse blocks on most models are located behind the instrument panel. Wires are color coded to indicate which accessory each fuse services. Some items, such as radios, may be fused individually at the unit.

## Fuel Systems

---

**CAUTION: It is very important that the fuel system be inspected thoroughly the first time it is filled and then at each subsequent filling. For your safety and the safety of your passengers, the fueling instructions in this manual must be followed.**

1. *Fuel Fills and Vents:*

Fuel fills are located either on the aft deck or on the side decks adjacent to the aft cockpit and are marked "Fuel" or "Gas". Fuel vents are normally located in the hull or transom below and in the same general area as the fill. If you experience difficulty filling the fuel tank, check to see that the fuel fill and vent lines are free of obstructions and kinks.

2. *Fuel Filters:*

All fuel tanks installed by Bayliner are equipped with a fine mesh screen filter on the fuel pick-up tube in the tank. In addition, when

supplied by the motor manufacturer, an additional filter is installed on the engine. Fuel filters should be checked periodically to see that they are clean and free of debris.

**CAUTION: Avoid the storage or handling of gear near the fuel lines, fittings and tank.**

## **Starter Motor**

---

The engine starter motor is designed to deliver high horsepower for only very short periods of time. Avoid operation for more than 15 seconds at a time. Due to its high horsepower, this motor builds up considerable heat and can be permanently damaged with prolonged use. If it does not operate, check the battery charge and all direct wiring for shorts or loose connections.

## **Bilge Pump**

---

The electric bilge pump supplied with your Bayliner is an impeller-type pump. If bilge water is present and the pump motor is running but not pumping, check to see if it is clogged by debris. If it is clear but still does not pump, check the discharge hose for kinks or a collapsed area.

**NOTE: The Federal Water Pollution Control Act prohibits the discharge of oil or oil waste into or upon the navigable waters and contiguous zone of the United States if such discharge causes a film or sheen upon, or discoloration of, the surface of the water, or causes a sludge or emulsion beneath the surface of the water. Violators are subject to penalty of \$5000.**

## **Running Lights**

---

The navigation lights supplied with Bass Trophy and Fish-N-Ski models are on posts which may be detached when the lights are not in use. When the lightposts are removed and stored (in a safe place), make sure the receptacle cover is snapped closed so that nothing can become lodged in the receptacle. Although the navigation lights are of top quality, failure may occur for a variety of reasons:

1. There may be a blown fuse. (Replace fuse in switch panel.)
2. The bulb may be burned out. (Carry spare bulbs for replacement.)
3. The post or receptacle may be corroded. (Clean periodically and coat with nonconductive grease.)

4. A wire may have come loose, or may be damaged. (Repair as required.)

**NOTE: Prolonged operation of lights (overnight) will result in a dead battery. Be conservative in the use of battery power.**

## **Livewells**

---

On models equipped with livewells, the pump is located aft, adjacent to the bilge pump. Switches for the livewells are located on the forward electrical panel and on the main dash panel. These switches activate aerators that pump a continuous supply of fresh water into the livewell. The overflow is automatically drained overboard. Shutoff valves are located inside both livewells, making it possible to turn off one livewell and run the other independently. It is advisable to occasionally check the live-wells when they are operating to see if the aerators are pumping adequate amounts of water. If there appears to be a problem, check the system for weeds or other debris.

## **Electric Trolling Motor**

---

Electric motors with remote foot controls are standard on Bass Trophy and Fish-N-Ski models. On the 1710 and 1810 models, the motor is mounted on the bow and is plugged in at the forward electrical panel. When operating, the motor draws power from its own battery. (A voltmeter at the forward electrical panel is provided for this battery.) On model 1510, no plug is provided; the motor connects directly to the battery. Be sure to keep the battery properly charged, as the motor's performance will be reduced when run at low voltages. Charging instructions can be found in the "Electrical Systems" section.

When lowering or raising the motor over the side, use the rope provided in order to avoid injury to yourself and damage to the boat or motor. The area behind the prop should occasionally be checked for weeds, fishing line and other debris. Also, after use in saltwater, rinse the unit with fresh water. During periods of extended nonuse, remove and store the motor. Operating instructions are included in the electric motor owner's manual supplied with your boat.

## **Ski Tow Posts**

---

Fish-N-Ski models are equipped with removable ski posts. It is important to make sure all three pins are secured before using the ski tow post.

## **Pedestal Seats**

---

Fore-and-aft pedestal seats should be removed and stowed in a safe and secure area when running or trailering your boat.

## **GENERAL MAINTENANCE AND REPAIRS**

---

In addition to instructions found elsewhere in this manual and in the literature specific to certain components, the following information is provided for general maintenance and repair.

Because conditions vary widely in different areas, and the frequency and type of use can differ greatly between owners, intervals for maintenance are not listed here. Common sense should determine the frequency of maintenance.

### **Bilges/Engine**

---

1. Pump bilges dry and remove all loose dirt. Be sure all limber holes are open. If there is oil in the bilge and the source is not known, look for leaks in engine oil lines or engine gaskets. Oil stains are best removed by use of a bilge cleaner available from your dealer or a marina. Do not use flammable solvents.
2. Inspect the entire fuel system (including fill lines and vents) for any evidence of leakage. Any stains around joints could indicate a leak. Try a wrench on all fittings to be sure they are not loosening, but do not overtighten them. Clean fuel filters and vent screens.
3. Inspect the entire bottom for evidence of seepage, damage or deterioration, paying particular attention to hull fittings, hoses and clamps. Straighten kinked hoses and replace any that do not seem pliable. Tighten loose hose clamps and replace those that are corroded. Tighten any loose nuts, bolts or screws.
4. Refer to your engine operating manual for details of maintenance. Wipe off the engine to remove accumulated dust and grease. If a solvent is used, make sure it is nonflammable. Go over the entire engine and tighten nuts, bolts, and screws, including the mounts. Inspect the wiring on the engine and clean and tighten terminals. Inspect belts and tighten if needed. Replace any belt that is cracked or frayed. Clean and lubricate battery terminals; fill battery cells with distilled water as needed.

## Cabin and Topside Areas

---

1. Check all wiring to be sure it is properly supported, insulation is intact and there are no loose or corroded terminals. Corroded terminals should be thoroughly cleaned with sandpaper or replaced. Tighten securely using a lock washer and spray with WD-40 or similar preservative.
2. Check bow rails, ladders and grab rails for loose screws, breaks, sharp edges, etc., that might be hazardous in rough weather. Inventory and inspect life jackets for tears and deterioration. Check your first aid kit to make sure it is complete. Check signaling equipment. Inspect anchor lines, mooring and towing lines and repair or replace as required. DO NOT stow wet lines or they may mildew and rot.
3. Salt and brackish water are capable of etching and damaging window glass. Keeping windows clean is the best preventive measure you can take. When cleaning, flush with plenty of fresh water.

Exercise caution when cleaning windows and doors made of plexiglass because it tends to scratch easily.

First, use generous amounts of water to wash off as much dust as possible. Use your bare hands with plenty of water to dislodge any caked dirt. Then use a soft grit-free cloth or clean soft sponge with a detergent or nonabrasive soap. Dry with a clean damp chamois, using a blotting action. Never use a glass cleaning solution or a duster as they will scratch the surface. Remove any grease or oil with kerosene or hexane. DO NOT use solvents such as acetone, benzine, carbon tetrachloride, fire extinguisher fluid, dry cleaning fluid, or lacquer thinner since they will attack the surface.

4. To keep teak looking fresh, it should be treated with teak oil at least twice a year (more often if exposure is severe). If the teak is in particularly bad condition, the teak oil should be rubbed in using 220 grit wet-or-dry sandpaper.
5. Use nearly any of the metal cleaners on the market today to spruce up hardware. After a good cleaning, a coat of paste wax will add greatly to its luster. All metal fittings and hardware should be sprayed with a rust inhibitor similar to WD-40. If not maintained on a regular basis, stainless steel railings and fittings will discolor.

6. A variety of high quality fabrics have been used in the construction of your boat. Proper care and cleaning of all fabrics will contribute to their long life.

Prior to cleaning any fabric we suggest that you **test your cleaning solution and method** on a hidden or inconspicuous area.

Convertible tops and vinyl upholstery can be cleaned using a mild soap and water solution. Vinyl cleaners and conditioners are **NOT** recommended for use on Bayliner upholstery. To prevent rainwater seepage at the seams, a coating of "Scotch Guard" can be applied on the inside of the vinyl. Mildew can occur if your boat does not have adequate ventilation. Heat alone will not prevent mildew. If mildew does occur, it can be removed using a solution of hot water and laundry bleach (one cup of bleach to one gallon of hot water). Brush into affected area, let sit for 10 to 15 minutes and rinse with plenty of fresh water. If at all possible, the vinyl top parts of your boat should be stored indoors in a fairly warm, dry place. This will greatly extend the life of the material.

Dry cleaning should be considered for interior fabrics other than vinyl.

7. When instruments are exposed to a saltwater environment, salt crystals may form on the bezel and the plastic covers. These salt crystals should be removed with a soft damp cloth; never use abrasives or rough dirty cloth to wipe plastic parts. Mild household detergents or plastic cleaners can be used to keep the instruments bright and clean.

## Hull

---

1. The finish on a fiberglass boat is similar to that of an automobile and will respond to the same system of care and cleaning. Car waxes and cleaners are often used to maintain a sparkling finish. Also, a variety of polishes and cleaners for fiberglass are now on the market. We suggest you experiment with different brands to determine what you like best.
2. Almost unavoidable during the life of your boat is damage to the gelcoat or colored surface. This is not as serious as you might think. Repair is not costly and can be done by the novice.



*Scratches:* If the scratch does not penetrate the gelcoat surface, it can be repaired with automotive rubbing compound. Dampen a soft rag and apply the compound by rubbing in a circular motion. The scratch may not disappear completely; however, its noticeability will decrease.

*Gouges and Chips:* To repair, simply obtain "patch paste" from your Bayliner dealer and follow this recommended procedure:

- Clean area to be repaired of wax and oil. Acetone is a good solvent.
- Mix a small portion of patch paste and catalyst on a piece of cardboard (two or three drops of catalyst to a tablespoon of paste).
- Apply to pit, chip, or gouge with a putty knife or flat-edged stick; try to match the surface contour of the area being repaired. It is better to have an excess of paste, rather than not enough.
- Allow the paste to harden thoroughly. In most climates, one to two hours should be sufficient.
- Shape the patch as desired, using fine wet sandpaper.
- Finish by using automotive rubbing compound in the same manner as you did for scratches.

**WARNING! Teak oil, acetone and catalyst are hazardous materials and should be used only in well ventilated areas. Follow manufacturer's instructions.**

### 3. Special Care for Boats That Are Moored

If permanently moored in salt water or fresh water, your boat will collect marine growth on its bottom. This will detract from the boat's beauty and greatly affect its performance. There are two methods of preventing this:

- Periodically haul the boat out of the water and scrub the bottom with a bristle brush and a solution of soap and water.
- Paint hull below waterline with a good grade of antifouling paint.

**IMPORTANT: Bayliner recommends the application of an epoxy barrier coating, such as International Paint Company's Interlux "Interprotect 2000 System", to help seal the hull bottom and reduce the possibility of gelcoat blistering. The barrier coating should be covered with several coats of antifouling paint. Note that many states regulate the chemical content of bottom paints in order to meet environmental standards. Check with your local Bayliner dealer about recommended bottom paints, and about laws that are in effect in your area.**

4. Whenever your boat is out of the water you should check all metal parts for stray current corrosion. Stray current corrosion, or electrolysis, can be prevented several ways. The following are the most common causes and the simplest cures:
  - Wiring may leak a certain amount of electricity. Keep a clean dry bilge.
  - A poorly grounded zinc anode: Check ground wire, clean contact surfaces.
  - The zinc anode may be deteriorated beyond effectiveness. Replace at 50% loss.
  - Do not use a copper-based bottom paint, as it can cause electrolysis on some metal parts. If your boat is permanently moored we recommend you contact someone in your area specializing in corrosion control and have them check your boat in its moorage to see that it is properly protected.
  
5. Propellers should be inspected often for damage. Every attempt has been made to equip your boat with a propeller that will optimize performance. However, your boating needs may dictate a propeller change. Your Bayliner dealer can help you in the selection of propellers better suited to your needs.

On those high performance Bayliner models capable of speeds in excess of 50 mph, "cavitation burn" may be experienced on the propeller. Propellers on these boats should be checked frequently for cavitation burn if the boat is continuously operated at high speeds. Replace propellers as necessary when severe burn occurs. High performance propellers constructed of bronze or stainless steel are available from the propeller manufacturers, but using these could void the warranty of your drive unit.

## **STORAGE**

---

The following suggestions are offered for storage at the end of your boating season.

1. Your boat should be stored under cover if possible. If covered storage isn't available, a temporary winter cover is recommended. A proper winter cover should keep weather off the boat, but still provide adequate ventilation. Wrapping a boat up in a tight plastic cover can do more damage than good. Dampness and lack of air circulation provide ideal conditions for fungi that cause mildew and dry rot.

2. If storing on a trailer:
  - Now is a good time to repack wheel bearings. Your local auto service center can help you.
  - Block the trailer wheels off the ground to avoid tire deterioration.
  - Loosen stern tie downs to avoid stress on hull.
3. Refer to your engine manual for storage instructions.
4. Remove the marine battery from the boat. Fill the cells to proper level and store in a warm place. A fully charged battery will survive storage better.
5. Fuel tanks should be filled so there is little air space, thereby minimizing condensation.
6. Thoroughly clean your boat. If possible, remove cushions, mattresses, towels, and other items that can hold moisture and cause mildew. Such items left on board should be positioned for maximum air circulation—stand mattresses and cushions on edge.
7. Clean hardware and coat with rust inhibitor.
8. Lubricate steering mechanism and throttle control.

We hope these preventive measures will help make getting ready again in the spring easier. Should you have any questions, your Bayliner dealer is eager to provide assistance.

## NAUTICAL TERMS

---

ABEAM:	On either side of the boat.
AFT:	To the rear or near the stern.
BEAM:	The width of the hull.
BILGE:	The lowest portion inside a boat (in a fiberglass boat, generally the underdeck and lower portion of the engine compartment).
BOW:	The forward portion of the boat.
CHINE:	The intersection of the side and bottom of a V-bottom boat.
DRAFT:	Vertical distance from the waterline of boat to the lowest point of the boat.
FATHOM:	A measurement of six feet generally used to measure water depth.
FREEBOARD:	Vertical distance from deck to waterline.
GUNWALE:	The point where hull and deck meet.
HATCH:	A covered opening in the deck.
HEAD:	Toilet or toilet room.
HELM:	Steering wheel.
KEEL:	The lowest external portion of the boat.
KNOT:	Nautical mile per hour; nautical mile is 6,076 ft.; land mile is 5,280 ft.
LEE:	Opposite from which the wind blows.
MAYDAY:	International spoken distress signal for radiotelephone.
PORT:	To the left side of the boat.
PORTLIGHT:	A hinged window in the boat's cabin or hull.
SCUPPER:	An opening in a deck or cockpit permitting water to drain overboard.
STANCHION:	A fixed, upright post used for support (of rails or lifelines).
STARBOARD:	To the right side of the boat.
STERN:	The rear of the boat.
STERNDRIVE:	Inboard/outboard propulsion unit.
TRANSOM:	The vertical part of the stern.
WINDWARD:	The direction from which the wind is blowing.

# SCHEMATIC WIRING DIAGRAM

1510 Bass Trophy

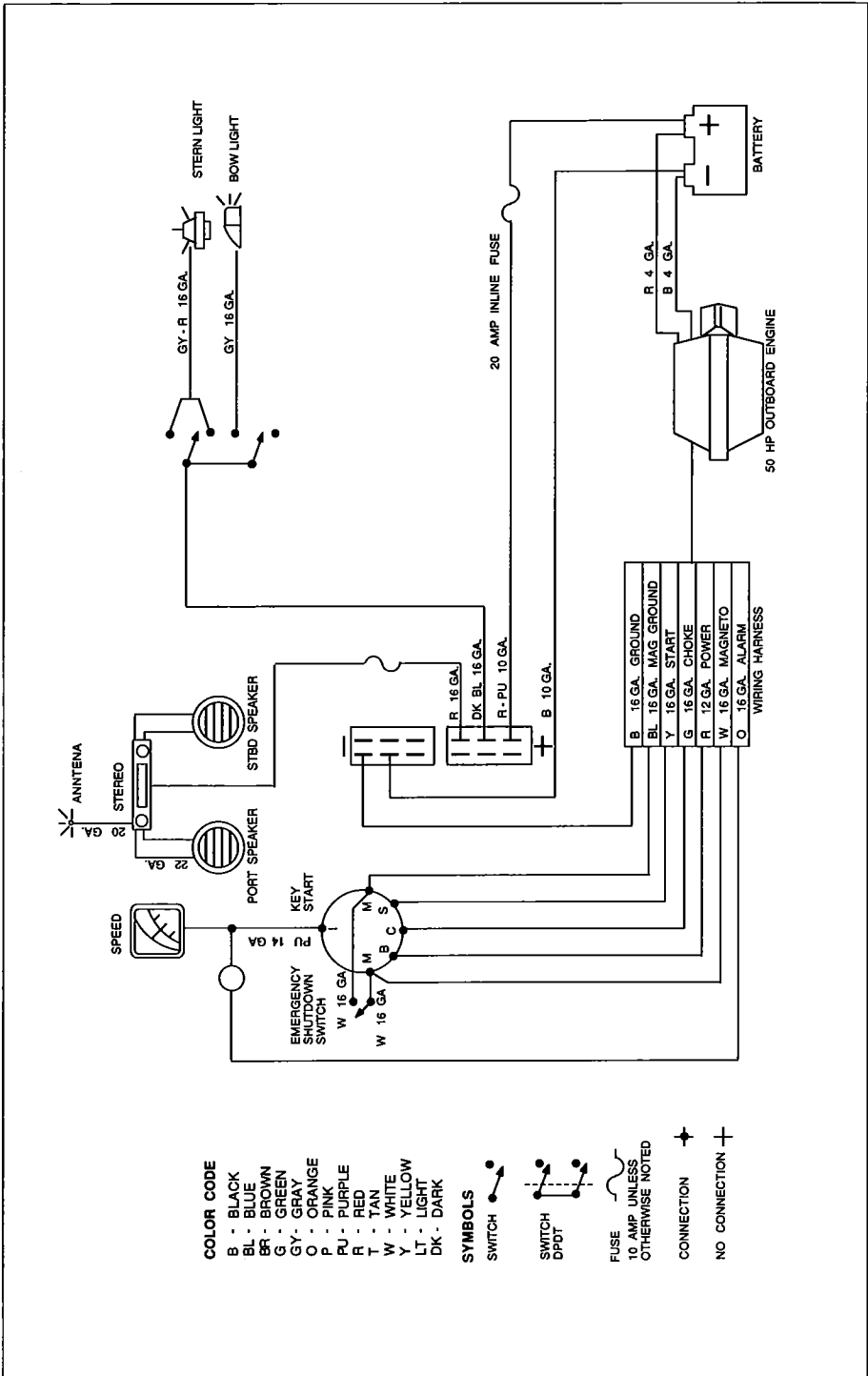



## **WARRANTY**

---

### **One Year Limited Warranty**

---

Bayliner warrants to the original purchasers of its boats operated under normal, noncommercial use in the U.S. or Canada that it will repair or replace any parts found to be defective in factory materials or workmanship within one year from the date of retail delivery.

### **What Is Not Covered**

---

This warranty does not apply to: (1) Engines, controls, props, batteries or other equipment or accessories carrying their own individual warranties; (2) Engines, parts or accessories not installed by Bayliner; (3) Window breakage or leaks; gelcoat finish, blisters, cracks or crazing; (4) Hardware, vinyl tops, vinyl and fabric upholstery, plastic, metal, wood or tape trim; (5) Any Bayliner boat which has been altered, subjected to misuse, negligence or accident, or used for racing purposes; (6) Any Bayliner boat which has been overpowered according to the maximum horsepower specifications on the capacity plate provided on each Bayliner outboard boat; (7) Any Bayliner boat used for commercial purposes; (8) Any defect caused by failure of the customer to provide reasonable care and maintenance.

### **Other Limitations**

---

THERE IS NO OTHER EXPRESS WARRANTY ON THIS BOAT. TO THE EXTENT ALLOWED BY LAW:

1. Any implied warranty of merchantability is limited to the duration of this written warranty.
2. Neither Bayliner nor the selling dealer shall have any responsibility for loss of use of the boat, loss of time, inconvenience, commercial loss or consequential damages.
3. Some states do not allow limitations on how long any implied warranty lasts, so the above limitation may not apply to you. Some states do not allow the exclusion or limitation of incidental or consequential damages, so the above limitation or exclusion may not apply to you. This warranty gives you specific legal rights, and you may also have other rights which vary from state to state.

### **Your Obligation**

---

In order to comply with Federal regulations, it is essential that your warranty registration card be submitted within 30 days of delivery of your boat. Return of this card is a condition precedent to warranty coverage. Before any warranty work is performed, we require that you contact your selling dealer to request warranty assistance.

We require that you return your boat, at your expense, to your selling dealer or, if necessary, to the Bayliner factory. You will be responsible for all transportation, haulouts and other expenses incurred in returning the boat for warranty service.

Bayliner Marine Corporation  
PO Box 24467  
Seattle, WA 98124

---

---

BAYLINER MARINE CORPORATION,  
PO Box 24467, Seattle, WA 98124, 206-435-5571, Telex 474-0071 BAYLINER ALG