

BAYLINER®

Classic Runabouts

Owner's Manual *Supplement*

Engine Serial Number: _____

Hull Identification Number: _____

Hull Identification Number

- The Hull Identification Number (HIN) is located on the starboard side of the transom.
- Record the HIN (and the engine serial numbers) in the space provided above.
- Refer to the HIN for any correspondence or orders.



© 2003 Bayliner Technical Publications. All rights reserved.

No part of this publication may be reproduced, stored in any retrieval system, or transmitted in any form by any means, electronic, mechanical, photocopying, recording or otherwise, without prior written permission of Bayliner.

Printed in the United States of America.

General Notes

The material in this document is for information only and is subject to change without notice. While reasonable efforts have been made in the preparation of this document to assure its accuracy, Bayliner assumes no liability resulting from errors or omissions in this document, or from the use of information contained herein.

Due to our commitment to product improvement, Bayliner reserves the right to make changes in the product design, specifications, and equipment at any time without notice or obligation. Illustrations and/or photos may show optional equipment.

All Bayliner products meet or exceed USCG (United States Coast Guard) and/or NMMA (National Marine Manufacturer's Association) construction standards. Manufactured with 1,1,1 Trichloroethane, a substance which harms public health and environment during the manufacturing process by destroying ozone in the upper atmosphere.

Proprietary Rights

This document discloses subject matter in which Bayliner has proprietary rights. The information and design disclosed herein were originated by and are the property of Bayliner. Neither receipt nor possession thereof confers or transfers any right to reproduce, copy, alter or disclose the document or any part thereof, any information contained therein, or to construct boats or any item from it, except by written permission from or written agreement with Bayliner. This document is to be returned upon request to Bayliner.

CONTENTS

1 Chapter 1: Welcome Aboard!

- 1 Dealer Service
- 1 Warranty Information
- 1 Boating Experience
- 2 Safety Standards
- 2 Engine & Accessories Guidelines
- 3 Engine & Accessories Literature
- 3 Qualified Maintenance
- 3 Special Care For Moored Boats
- 4 Carbon Monoxide (CO)
 - 4 *Facts about CO*
 - 5 *Where and How CO Can Accumulate*
 - 5 *How to Protect Yourself and Others From CO*
 - 6 *Trip Checklist*
 - 6 *Monthly Checklist*
 - 6 *Annual Checklist*
 - 6 *More Information*

7 Chapter 2: Product Specifications

- 7 195
- 7 192
- 8 194
- 8 215
- 9 210

10 Chapter 3: Locations

- 10 Exterior Views
 - 10 *Hull Views*
 - 10 *195, 192 & 194*
 - 11 *215 & 210*
 - 12 *195 Deck View*
 - 13 *192 Deck View*
 - 14 *194 Deck View*
 - 15 *215 Deck View*
 - 16 *210 Deck View*
- 17 Component Locations

18 Chapter 4: Propulsion & Related Systems

- 18 Engine
- 18 Engine Room Ventilation System
- 19 Fuel System
 - 19 *Fuel Fill and Vent*
 - 19 *Fuel Filters*
 - 19 *Anti-siphon Valve*
- 20 Quick Oil Drain System

21 Chapter 5: Controls

- 21 Steering
- 21 Shift/Throttle Lever
- 21 Power Trim and Tilt
- 21 Gauges
 - 21 *Cleaning Gauges*
 - 21 *Gauge Fogging*
 - 21 *Radio Transmission Interference*
 - 21 *Fuel Gauge*

22 Chapter 6: Plumbing

- 22 Drain Systems
 - 22 *Deck Drains*
- 22 Bilge Pump
- 24 Seawater System (If Equipped)
 - 24 *Seacock*
- 24 Portable Toilet (If Equipped)
- 25 Baitwell System (194 Only)

26 Chapter 7: Deck Equipment

- 26 Cleats and Tow Eyes
- 26 Ski Tow Ring
- 26 Pre-rigging For Trolling Motor (194 Only)
- 27 Canvas (If Equipped)
 - 27 195 & 192 Canvas Top (If Equipped)
 - 28 194 Canvas Top (If Equipped)
 - 29 215 & 210 Canvas Top (If Equipped)
 - 30 195 & 194 Bimini Top (If Equipped)
 - 31 215 Bimini Top (If Equipped)

32 Chapter 8: Entertainment Systems

- 32 Audio System

33 Chapter 9: Convertible Seats, Beds, & Tables

- 33 Sleeper Seats (If Equipped)
 - 33 Operating Positions
 - 33 Lounge positions
- 34 Jump Seat To Sunlounge Conversion
- 35 Removable Fishing Seats (194 Only)

36 Chapter 10: Lights

- 36 Care and Maintenance
- 36 Navigation Lights

37 Chapter 11: Electrical System

- 38 12-Volt DC System
 - 38 Battery
 - 38 Fuses and Circuit Breakers
 - 38 Alternator
 - 38 12-Volt Accessory Outlet
- 39 Electrical Routings
 - 39 192 Deck Electrical Harness
 - 40 194 Deck Electrical Harness
 - 41 195 Deck Electrical Harness
 - 41 210 Deck Electrical Harness
 - 42 215 Deck Electrical Harness
 - 42 195, 192 & 194 Hull Electrical Harness
 - 43 210 & 215 Hull Electrical Harness
 - 43 210 & 215 Battery Cable Harness
- 44 Wiring Diagram

45 Important Records

46 Float Plan

Hazard Boxes & Symbols

The hazard boxes and symbols shown below are used throughout this *Supplement* to call attention to potentially dangerous situations which could lead to either personal injury or product damage. **Read ALL warnings carefully and follow all safety instructions.**

 **DANGER!**
This box alerts you to immediate hazards which *WILL* cause severe personal injury or death if the warning is ignored.

 **WARNING!**
This box alerts you to hazards or unsafe practices which *COULD* result in severe personal injury or death if the warning is ignored.

 **CAUTION!**
This box alerts you to hazards or unsafe practices which *COULD* result in minor personal injury or cause product or property damage if the warning is ignored.

NOTICE
This box calls attention to installation, operation or maintenance information, which is important to proper operation but is not hazard related.

 FIRE HAZARD!	 EXPLOSION HAZARD!	 NO OPEN FLAME!	 ELECTRICAL HAZARD!	 HOT HAZARD!
---	--	---	--	--

 FALLING HAZARD!	 ROTATING PROPELLER HAZARD!	 RUN BILGE BLOWERS FOR 4 MINUTES!
--	---	--

DANGER
CARBON MONOXIDE
CO POISONING HAZARD!

Chapter 1: Welcome Aboard!

This *Owner's Manual Supplement* provides specific information about your boat that is not covered in the *Sport Boat Owner's Manual*. Please study the *Sport Boat Owner's Manual* and this *Supplement* carefully. Keep the *Sport Boat Owner's Manual* and this *Supplement* on your boat in a secure, yet readily available place.

Dealer Service

- Your dealer is your key to service.
- Ask your dealer to explain all systems before taking delivery of your boat.
- Contact your dealer if you have any problems with your new boat.
- If your dealer cannot help, call our customer service hotline: 360-435-8957 or send us a FAX: 360-403-4235.
- Buy replacement parts from any authorized Bayliner dealer.

Warranty Information

- Bayliner offers a Limited Warranty on each new Bayliner purchased through an authorized Bayliner dealer.
- A copy of the Limited Warranty was included in your owner's packet.
- If you did *not* receive a copy of the Limited Warranty, please contact your dealer or call 360-435-8957 for a copy.

Boating Experience

 WARNING!
<i>CONTROL HAZARD!</i>
A qualified operator <i>must</i> be in control of the boat at <i>all</i> times. <i>DO NOT</i> operate your boat while under the influence of alcohol or drugs.

If this is your first boat or if you are changing to a type of boat you are not familiar with, for your own comfort and safety, obtain handling and operating experience before assuming command of the boat.

Take one of the boating safety classes offered by the U.S. Power Squadrons or the U.S. Coast Guard Auxiliary. For more course information, including dates and locations of upcoming classes, contact the organizations directly:

- U.S. Power Squadrons: 1-888-FOR-USPS (1-888-367-8777) or on the Internet at: <http://www.usps.org>
- U.S. Coast Guard Auxiliary: 1-800-368-5647 or on the Internet at: <http://www.cgaux.org>

Outside the United States, your selling dealer, national sailing federation or local boat club can advise you of local sea schools or competent instructors.

Safety Standards

⚠ DANGER!





FALLING and ROTATING PROPELLER HAZARD!

NEVER allow anyone to ride on parts of the boat *not* designed for such use.

- **Sitting on seat backs, lounging on the forward deck, bow riding, gunwale riding or occupying the transom platform while underway is especially hazardous and will cause personal injury or death.**

⚠ DANGER!





ROTATING PROPELLER and CARBON MONOXIDE POISONING HAZARD!

- ***NEVER*** allow anyone to occupy, or hang from, the back deck or swim platform while the engine(s) are running.
- Teak surfing, dragging, or water skiing within 20 feet of a moving watercraft can be fatal.

⚠ DANGER!

PERSONAL SAFETY HAZARD!

ALWAYS secure the anchor and other loose objects before getting underway. The anchor and other items that are *not* properly secured can come loose when the boat is moving and cause personal injury or death.

- Your boat's mechanical and electrical systems were designed to meet safety standards in effect at the time it was built.
- Some of these standards were mandated by law, all of them were designed to insure your safety, and the safety of other people, vessels and property.

In addition to this *Owner's Manual Supplement*, please read the *Sport Boat Owner's Manual* and *all* accessory instructions for important safety standards and hazard information.

Engine & Accessories Guidelines

NOTICE

When storing your boat please refer to your engine's operation and maintenance manuals.

- Your boat's engine and accessories were selected to provide optimum performance and service.
- Installing a different engine or other accessories may cause unwanted handling characteristics.
- Should you choose to install a different engine or to add accessories that will affect the boat's running trim, have an experienced marine technician perform a safety inspection and handling test before operating your boat again.

Certain modifications to your boat can result in cancellation of your warranty protection. *Always* check with your dealer *before* making any modifications to your boat.

Engine & Accessories Literature

- The engine and accessories installed on your boat come with their own operation and maintenance manuals.
- Read and understand these manuals *before* using the engine and accessories.
- Unless noted otherwise, *all* engine and accessory literature referred to in this supplement is included in your owner's packet.

Qualified Maintenance



WARNING!

To maintain the integrity and safety of your boat, allow only qualified personnel to perform maintenance on, or in any way modify: The steering system, propulsion system, engine control system, fuel system, environmental control system, electrical system or navigational system.

- Failure to maintain your boat's systems (listed in the warning above) as designed could violate the laws in your jurisdiction and could expose you and other people to the danger of bodily injury or accidental death.
- Follow the instructions provided in the *Sport Boat Owner's Manual*, this *Owner's Manual Supplement*, the engine owner's manual and *all* accessory instruction sheets and manuals.

Special Care For Moored Boats

NOTICE

- **To help seal the hull bottom and reduce the possibility of gelcoat blistering on moored boats, apply an epoxy barrier coating. The barrier coating should be covered with several coats of anti-fouling paint.**
- **Many states regulate the chemical content of bottom paints in order to meet environmental standards. Check with your local dealer about recommended bottom paints, and about the laws in effect in your area.**

- Whether moored in saltwater or freshwater, your boat will collect marine growth on its hull bottom.
- This will detract from the boat's beauty, greatly affect its performance and may damage the gelcoat.
- Periodically haul the boat out of the water and scrub the hull bottom with a bristle brush and a solution of soap and water.

Carbon Monoxide (CO)

⚠ DANGER!	
	<ul style="list-style-type: none"> • Carbon monoxide gas (CO) is colorless, odorless, tasteless, and extremely dangerous. • <i>All</i> engines, generators, and fuel burning appliances produce CO as exhaust. • Prolonged exposure to low concentrations or very quick exposure to high concentrations <i>will</i> cause BRAIN DAMAGE or DEATH. • Teak surfing, dragging, or water skiing within 20 feet of a moving watercraft can be fatal.

Facts about CO

- CO poisoning causes a significant number of boating deaths each year.
- Called the "silent killer", CO is an extremely toxic, colorless, odorless and tasteless gas.
- CO can harm or even kill you inside or outside your boat.
- CO can affect you whether you're underway, moored, or anchored.
- CO symptoms are similar to seasickness or alcohol intoxication.
- CO can make you sick in seconds. In high enough concentrations, even a few breaths can be fatal.
- Breathing CO blocks the ability of your blood to carry oxygen.
- The effects are cumulative, even low levels of exposure can result in injury or death.

Factors That Increase the Effects of CO Poisoning

- Age
- Smokers or people exposed to high concentrations of cigarette smoke
- Consumption of alcohol
- Lung disorders
- Heart problems
- Pregnancy

Where and How CO Can Accumulate

Stationary Conditions That Increase CO Accumulations Include:

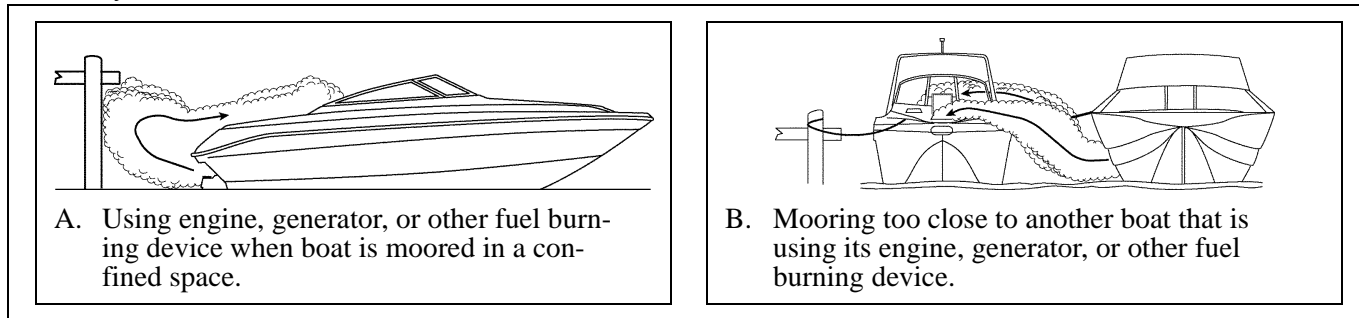

To correct stationary situations A and/or B:

- Close **all** windows, portlights and hatches.
- If possible, move your boat away from source of CO.

Running Conditions That Increase CO Accumulations Include:

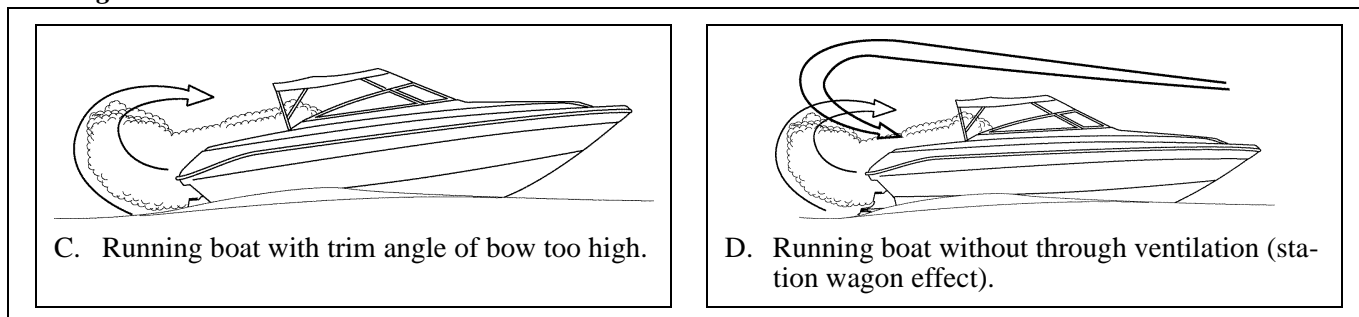

To correct running situations C and/or D:

- Trim bow down.
- **Open** windows and canvas.
- When possible, run boat so that prevailing winds help dissipate exhaust.

How to Protect Yourself and Others From CO

- Know where and how CO may accumulate in and around your boat (see above).
- Maintain fresh air circulation throughout the boat at **all** times.
- Know where your engine and generator exhaust outlets are located and keep everyone away from these areas.
- **Never** sit on, or hang onto, the back deck or swim platform while the engine(s) are running.
- **Never** enter the areas under swim platforms where exhaust outlets are located.
- Although CO can be present without the smell of exhaust fumes, if exhaust fumes are detected on the boat, take immediate action to dissipate these fumes.
- Treat symptoms of seasickness as possible CO poisoning. Get the person into fresh air immediately. Seek medical attention—unless you're sure it's **not** CO.
- Install and maintain CO alarms inside your boat. **Do not** ignore any alarm. Replace alarms as recommended by the alarm manufacturer.
- Follow the checklists provided on the next page.
- Get a Vessel Safety Check.

For information on how to get a free VESSEL SAFETY CHECK, visit www.vesselsafetycheck.org or contact your local U.S. Coast Guard Auxiliary or United States Power Squadrons®.

- U.S. Coast Guard Auxiliary: 1-800-368-5647 or on the Internet at: <http://www.cgaux.org>
- U.S. Power Squadrons: 1-888-FOR-USPS (1-888-367-8777) or on the Internet at: <http://www.usps.org>

Trip Checklist

- Make sure you know where the exhaust outlets are located on your boat.
- Educate *all* passengers about the symptoms of CO poisoning and where CO may accumulate.
- When docked, or rafted with another boat, be aware of exhaust emissions from the other boat.
- Confirm that water flows from the exhaust outlet when the engines and generator are started.
- Listen for any change in exhaust sound, which could indicate an exhaust component failure.
- Test the operation of each CO alarm by pressing the test button.

Monthly Checklist

- Make sure *all* exhaust clamps are in place and secure.
- Look for exhaust leaking from exhaust system components. Signs include rust and/or black streaking, water leaks, or corroded or cracked fittings.
- Inspect rubber exhaust hoses for burned, cracked, or deteriorated sections. *All* rubber hoses should be pliable and free of kinks.

Annual Checklist

Have a Qualified Marine Technician:

- Replace exhaust hoses if cracking, charring, or deterioration is found.
- Ensure that your engines and generators are properly tuned, and well maintained.
- Inspect each water pump impeller and the water pump housing. Replace if worn. Make sure cooling systems are in working condition.
- Inspect all metallic exhaust components for cracking, rusting, leaking, or loosening. Make sure they check the cylinder head gasket, exhaust manifold, water injection elbow, and the threaded adapter nipple between the manifold and the elbow.
- Clean, inspect, and confirm proper operation of the generator cooling water anti-siphon valve (if equipped).

More Information

For more information about how you can prevent carbon monoxide poisoning on recreational boats and other ways to boat more safely, contact:

United States Coast Guard

Office of Boating Safety (G-OPB-3)
2100 Second Street SW
Washington, DC 20593
www.uscgboating.org
1-800-368-5647

National Marine Manufacturers Association (NMMA)

200 East Randolph Drive
Suite 5100
Chicago, IL 60601-9301
www.nmma.org
312-946-6200

American Boat & Yacht Council, Inc. (ABYC)

3069 Solomon's Island Road
Edgewater, MD 21037-1416
www.abycinc.org
410-956-1050

For information on how to get a free VESSEL SAFETY CHECK, visit www.vesselsafetycheck.org or contact your local U.S. Coast Guard Auxiliary or United States Power Squadrons®.

- U.S. Coast Guard Auxiliary: 1-800-368-5647 or on the Internet at: <http://www.cgaux.org>
- U.S. Power Squadrons: 1-888-FOR-USPS (1-888-367-8777) or on the Internet at: <http://www.usps.org>

Chapter 2: Product Specifications

195

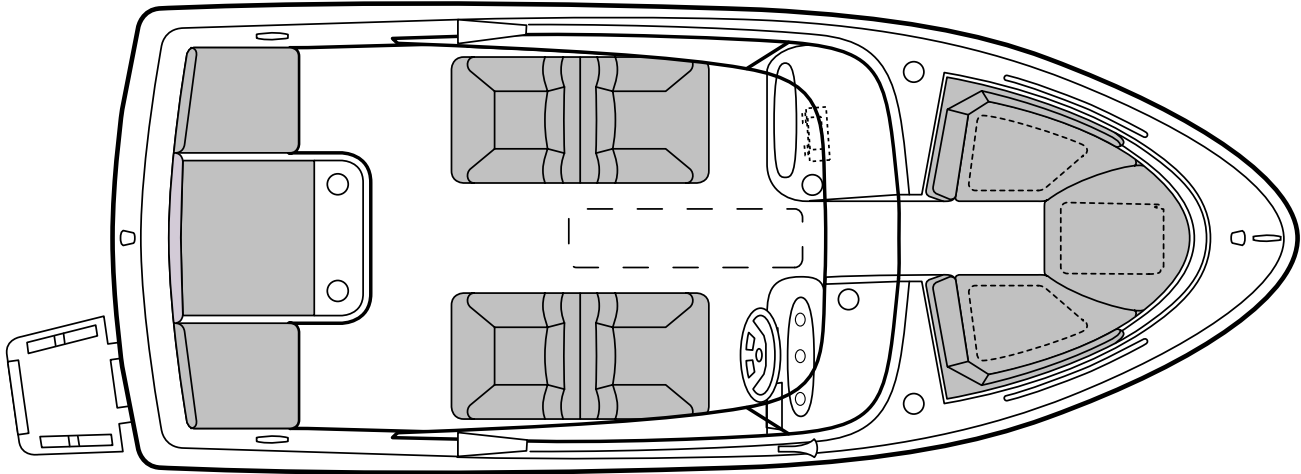

Overall Length	Bridge Clearance	Beam	Draft (Drive Up)	Draft (Drive Down)	Fuel Capacity (gal.)
18' 9"	3' 1"	7' 7"	1' 5"	2' 10"	23

192

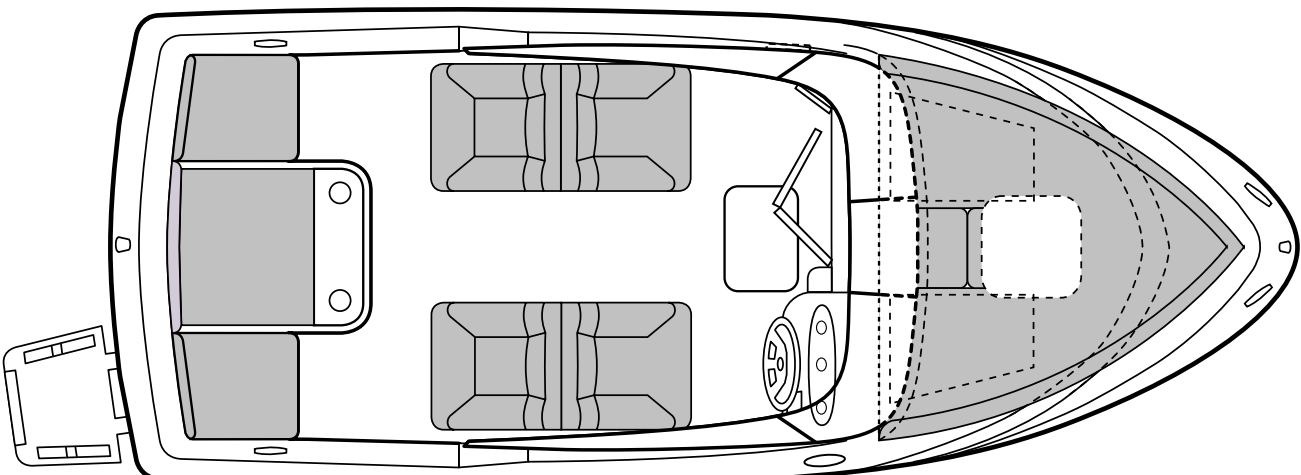

Overall Length	Bridge Clearance	Beam	Draft (Drive Up)	Draft (Drive Down)	Fuel Capacity (gal.)
18' 9"	3' 8"	7' 7"	1' 5"	2' 10"	23

194

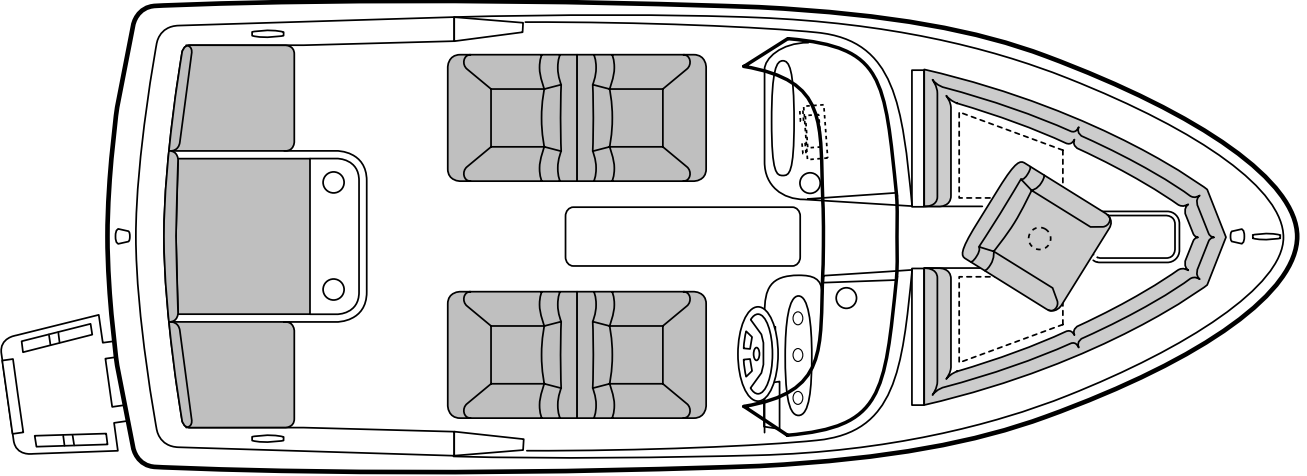

Overall Length	Bridge Clearance	Beam	Draft (Drive Up)	Draft (Drive Down)	Fuel Capacity (gal.)
18' 9"	3' 1"	7' 7"	1' 5"	2' 10"	23

215

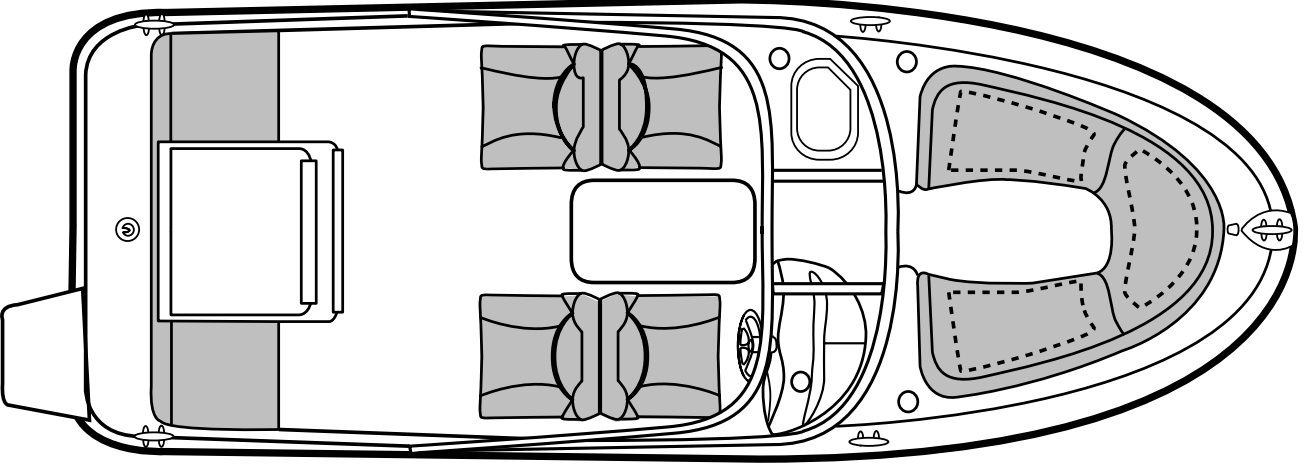

Overall Length	Bridge Clearance	Beam	Draft (Drive Up)	Draft (Drive Down)	Fuel Capacity (gal.)
20' 9"	4' 3"	8' 1"	1' 6"	2' 11"	37

210

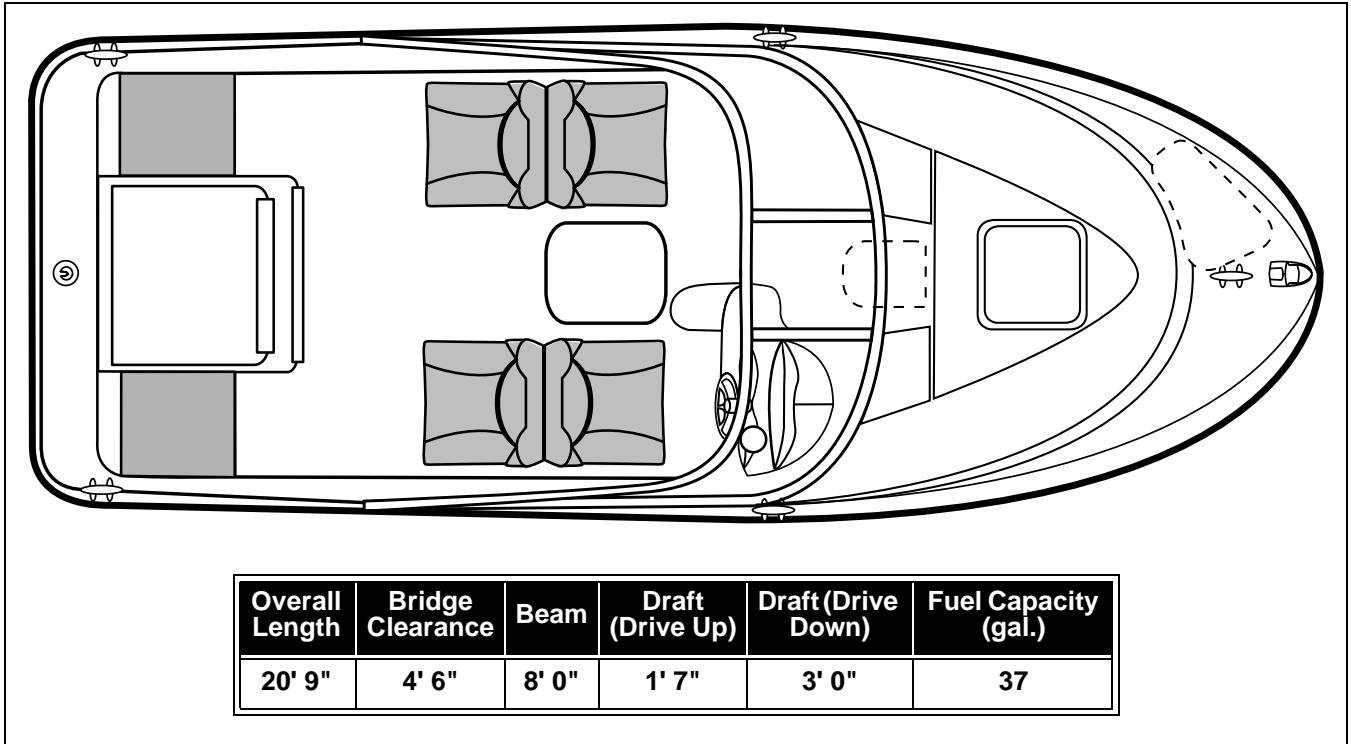

Chapter 3: Locations

Exterior Views

Hull Views

195, 192 & 194

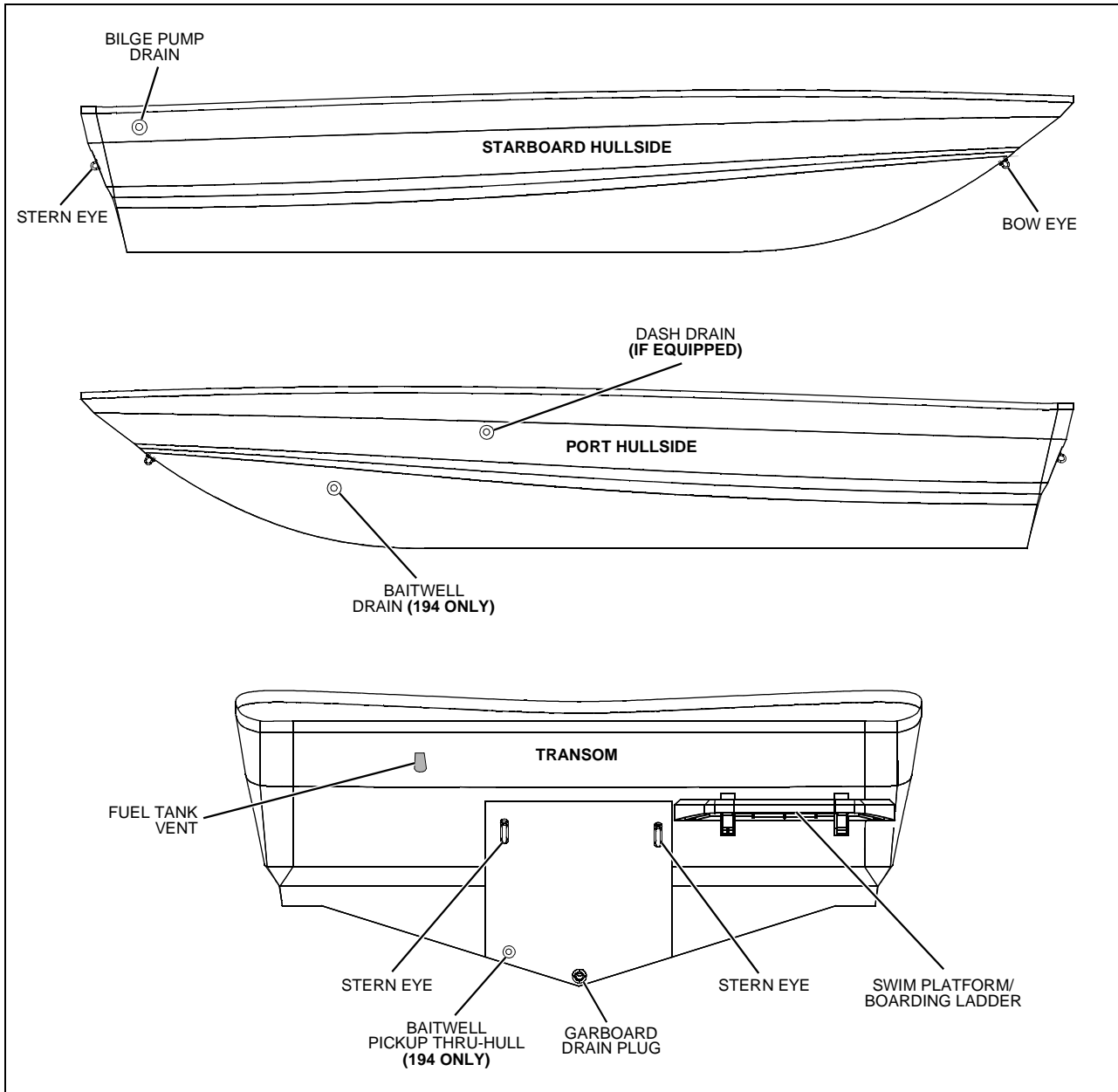

215 & 210

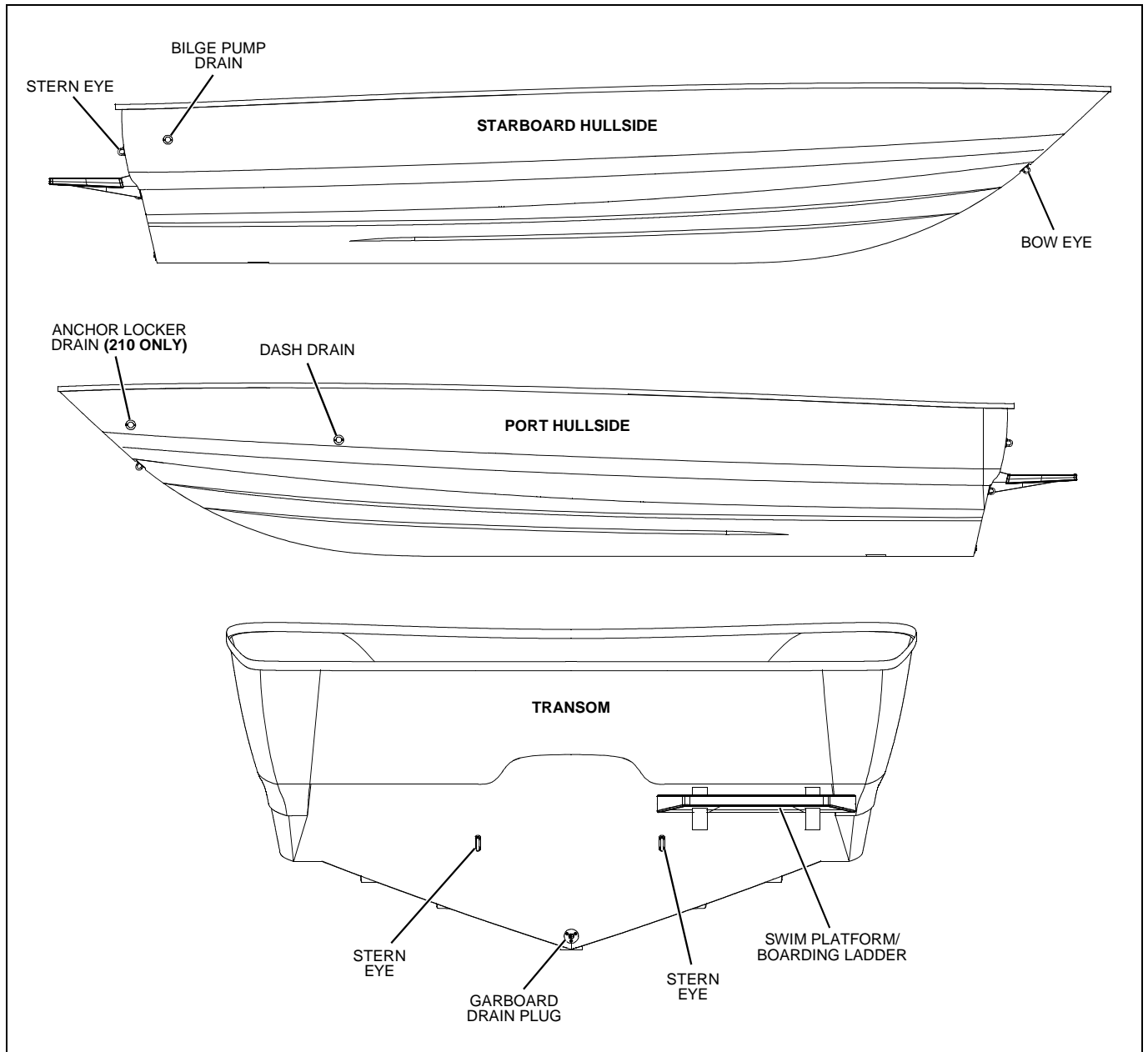

195 Deck View

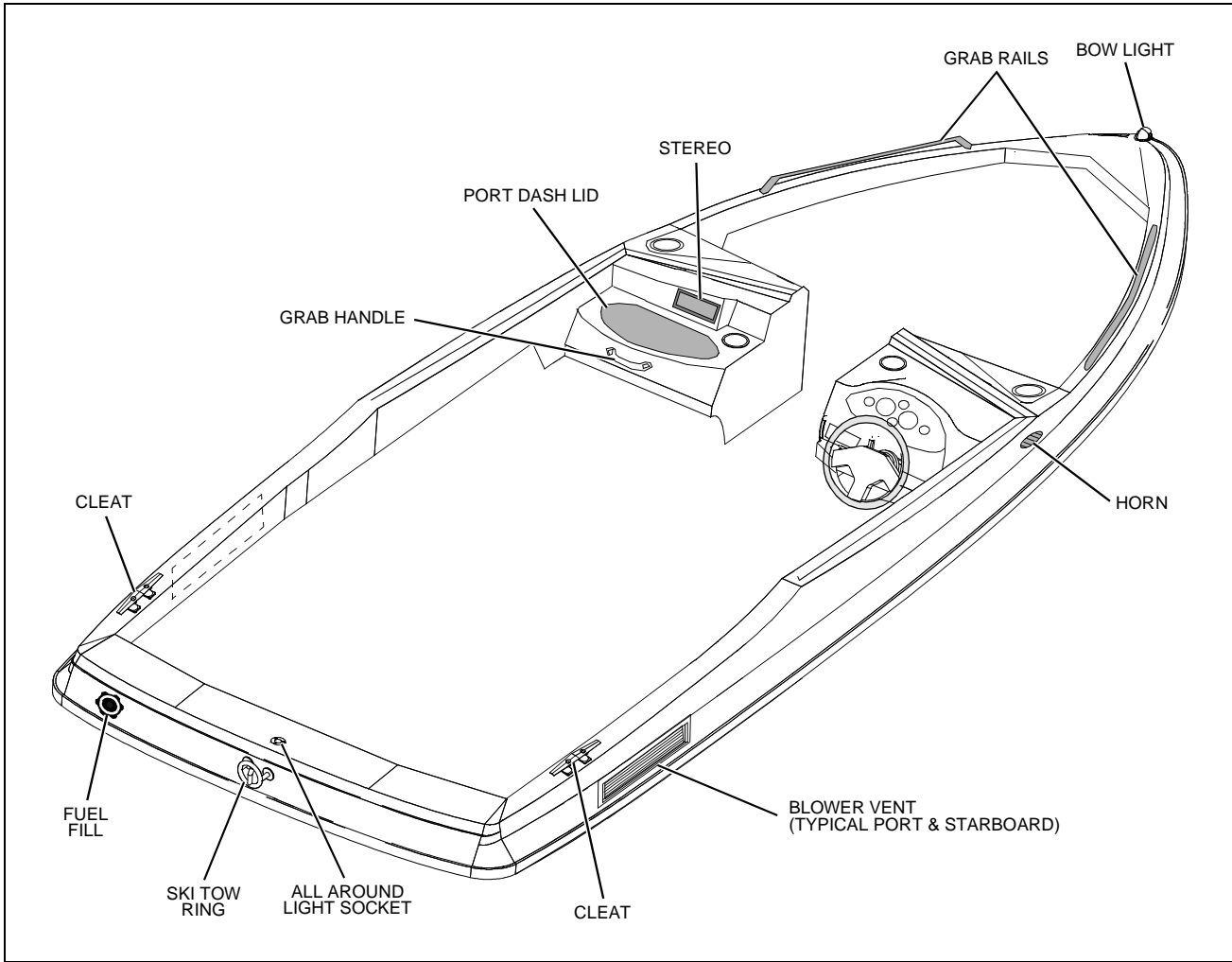

192 Deck View

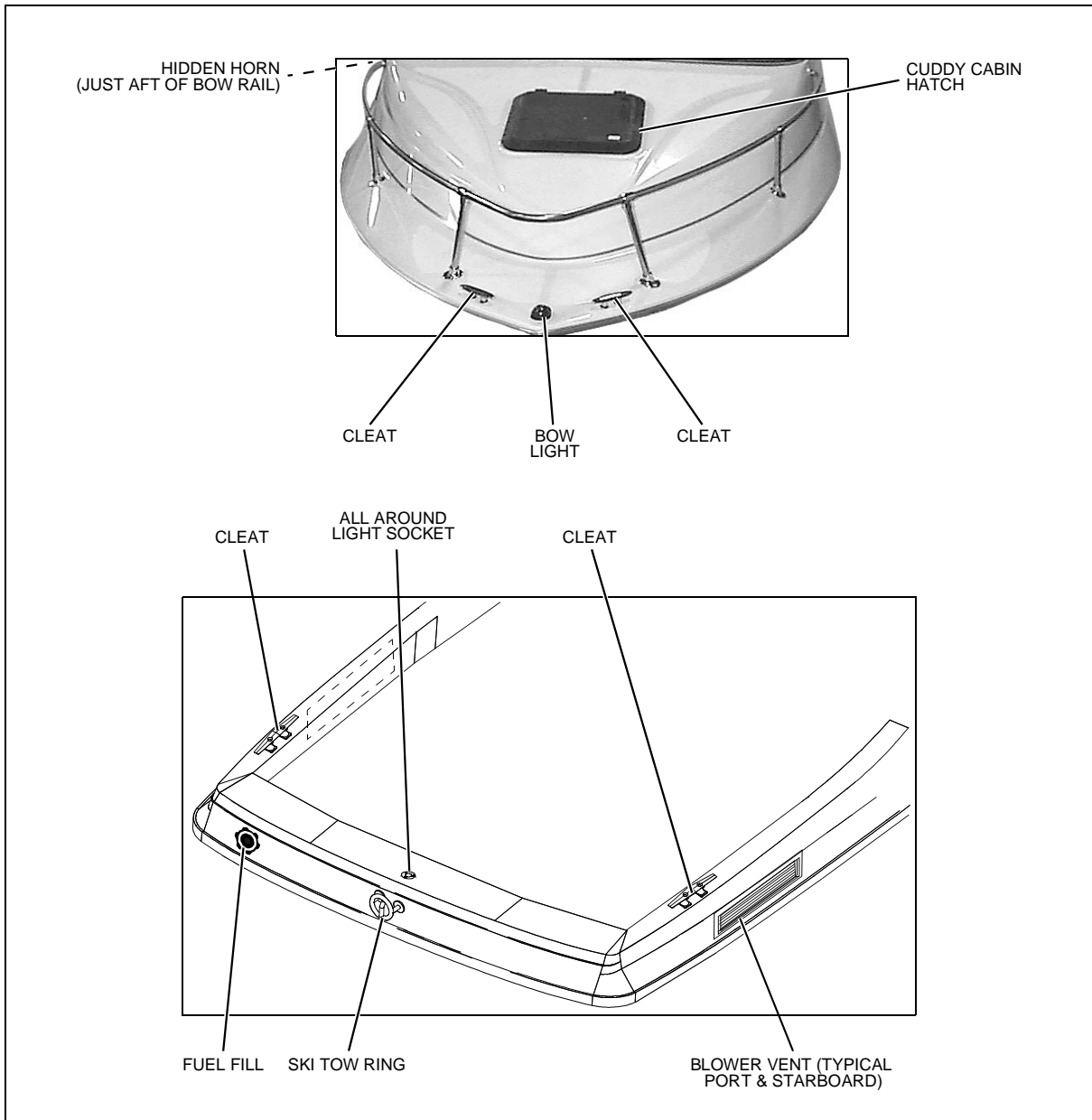

194 Deck View

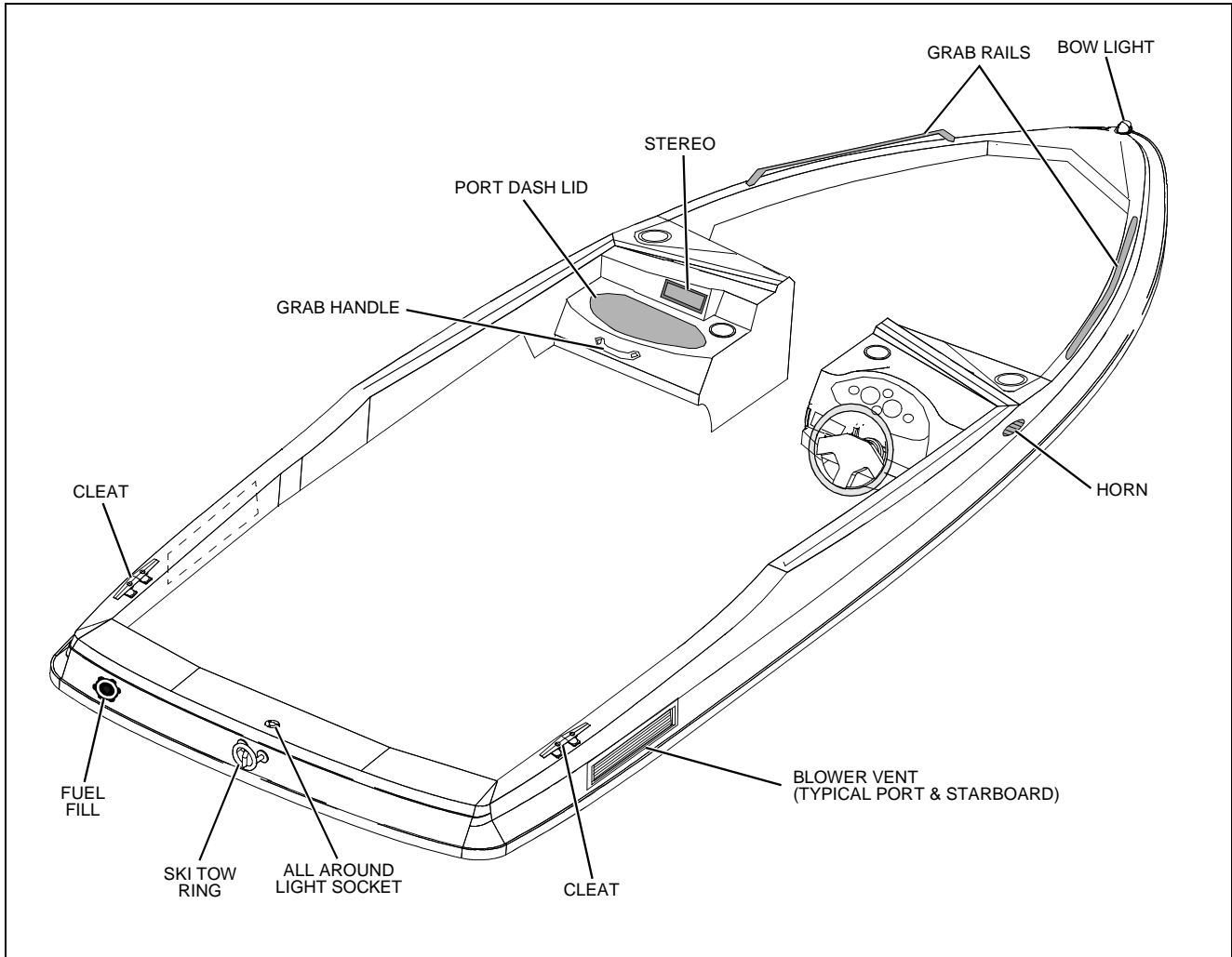

215 Deck View

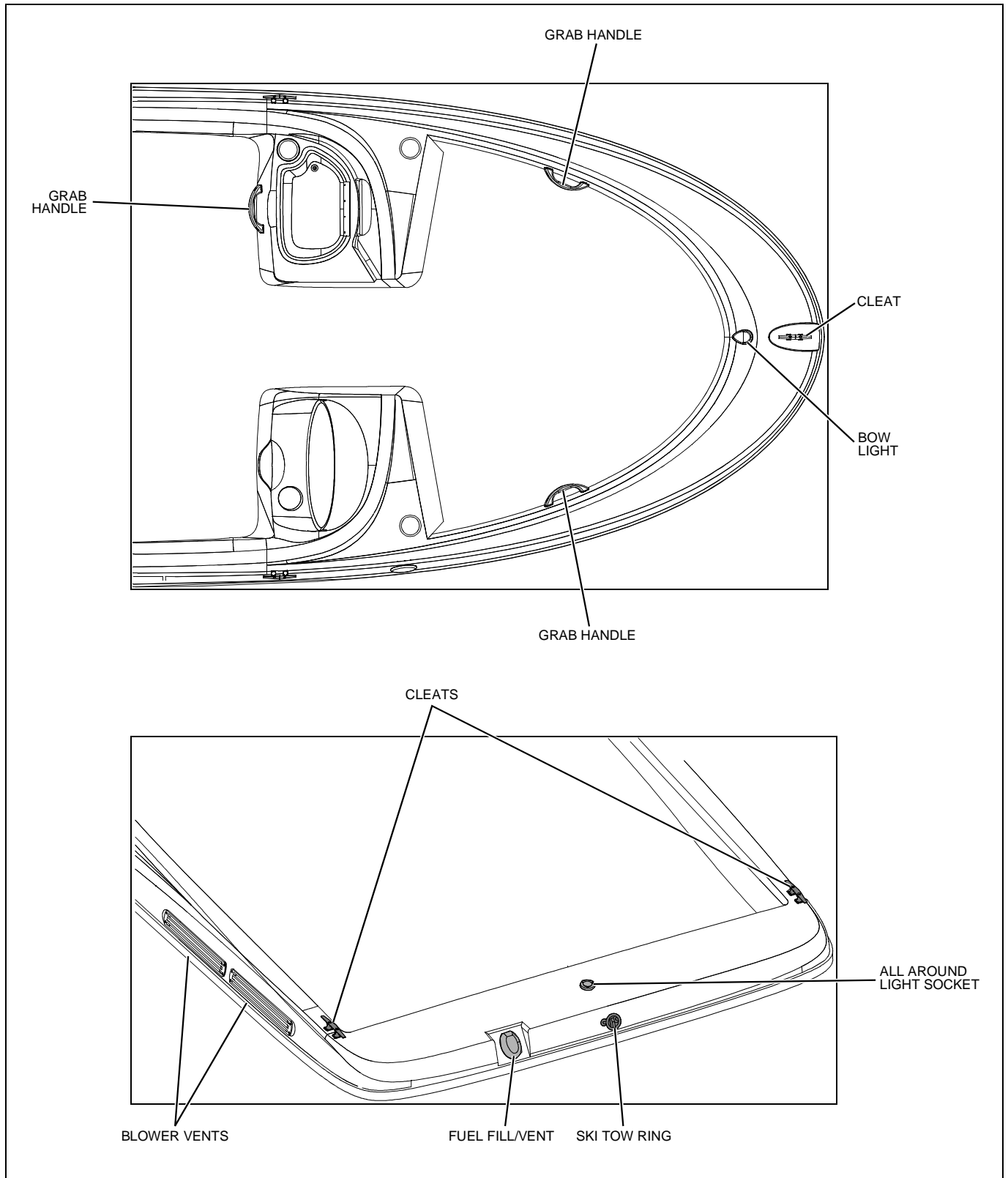

210 Deck View

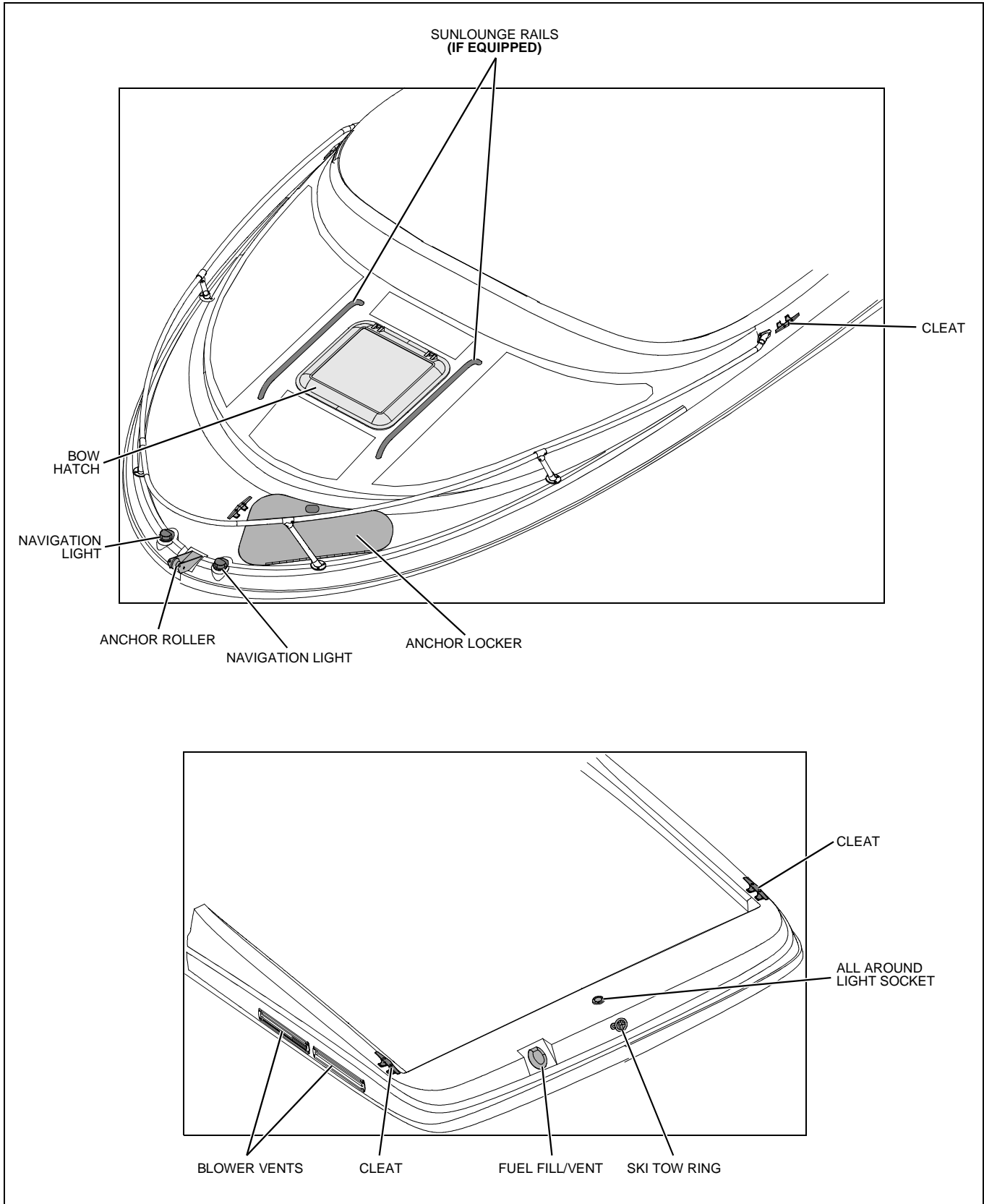

Component Locations

12-Volt Accessory Outlet: At the helm on the dash panel.

Battery: On the starboard side of the engine compartment

Bilge Pump: In the engine compartment, forward of the engine.

Engine Circuit Breaker: On the engine.

Fuse Block: At the helm, under the dash panel.

Fuel Fill: On the port side of the aft deck.

Navigation Lights: Red and green lights at the bow. White all-around light on the stern.

Chapter 4: Propulsion & Related Systems

Engine

Read and understand the engine operation and maintenance manual *before* starting the engine or doing any maintenance on the engine.

Engine Room Ventilation System

! WARNING!



FIRE/EXPLOSION HAZARD

- Use of the blower system is **NOT A GUARANTEE** that explosive fumes have been removed.
- If you smell fuel, **DO NOT** start the engine and **DO NOT** turn *On* any electrical devices.
- If you smell fuel and the engine is already running, **SHUT OFF** the engine and **TURN OFF** all electrical devices. Investigate immediately.
- **DO NOT** obstruct or modify the ventilation system.

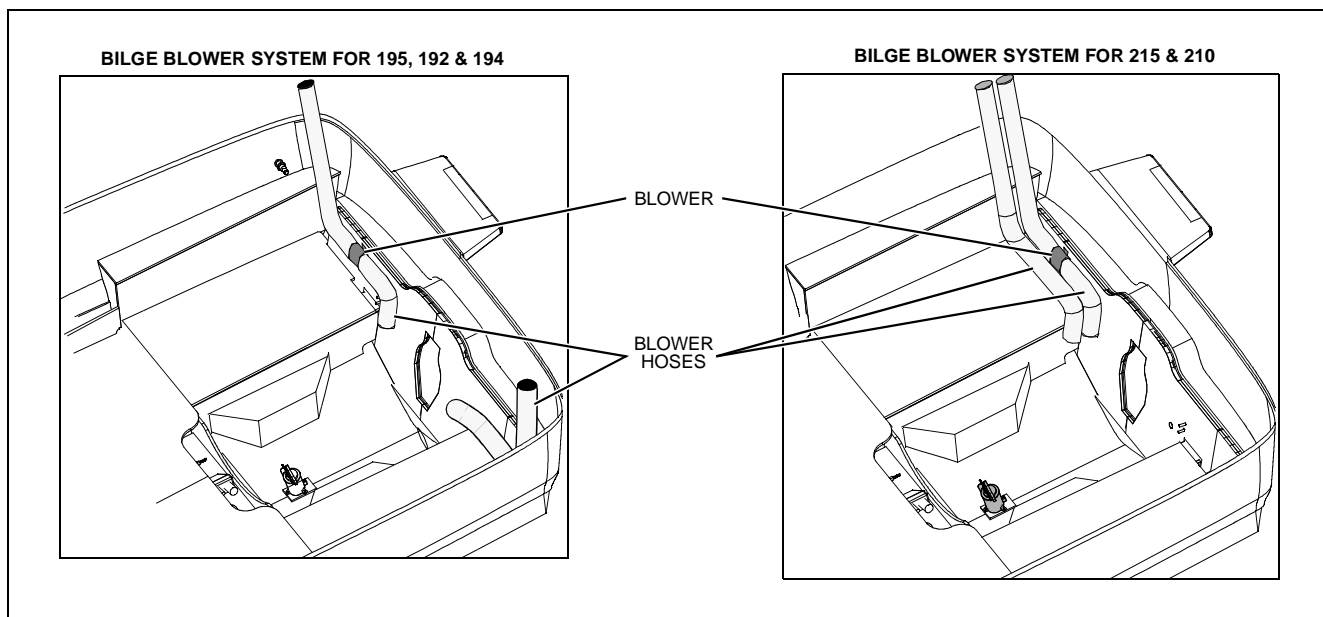

- The bilge blower removes explosive fuel fumes from the engine compartment.
- Fresh air is drawn into the compartment through the deck vents.
- The bilge blower switch is at the helm.

To make sure the engine compartment is ventilated with fresh air, run the bilge blower:

- For at least four minutes *before* starting the engine.
- During starting.
- Anytime your boat is running below cruising speed.

Fuel System

WARNING!



FIRE, EXPLOSION AND OPEN FLAME HAZARD!

- It is very important that the fuel system be inspected thoroughly the first time it is filled and at each subsequent filling.
- The fueling instructions in the *Sport Boat Owner's Manual* and the fuel recommendations in the engine operation manual *must* be followed.

CAUTION

Avoid the storage or handling of gear near the fuel lines, fittings and tank.

Fuel Fill and Vent

- The fuel fill/vent fitting is marked "GAS".
- If you experience difficulty filling the fuel tank, check to see if the fuel fill hose is kinked or collapsed. If there are no visible signs of a problem, contact your local dealer.

Fuel Filters

- The fuel pickup tube (located inside the fuel tank) is equipped with a fine mesh screen filter.
- In addition, when supplied by the engine manufacturer, a fuel filter is installed on the engine.
- Periodically replace the fuel filters to make sure they remain clean and free of debris.
- Talk to your selling dealer or local marina about fuel additives that help prevent fungus or other buildup in your fuel tank.

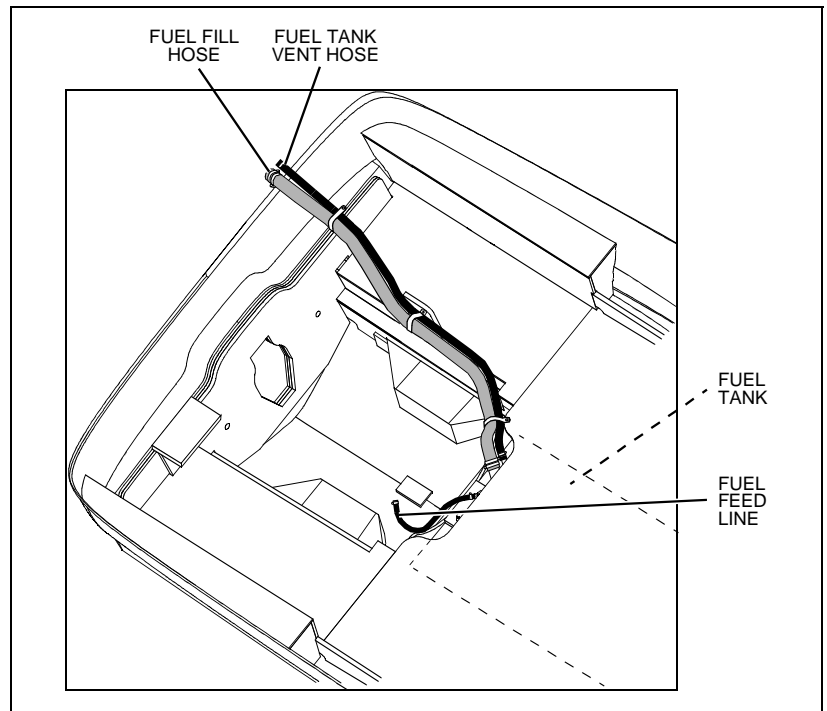

Anti-siphon Valve

NOTICE

- If an engine running problem is diagnosed as fuel starvation, check the anti-siphon valve. If the valve is stuck or clogged, change or replace it while the engine is shut down.
- **NEVER** run the engine with the anti-siphon valve removed, except in an emergency.

- Your boat is equipped with an anti-siphon valve, which is an integral part of fuel system.
- The valve is located at the point where the fuel feed line attaches to the fuel tank.
- The valve is spring loaded and is opened by fuel pump vacuum.
- This valve will prevent fuel from siphoning from the tank in the event of a fuel line rupture.

Quick Oil Drain System

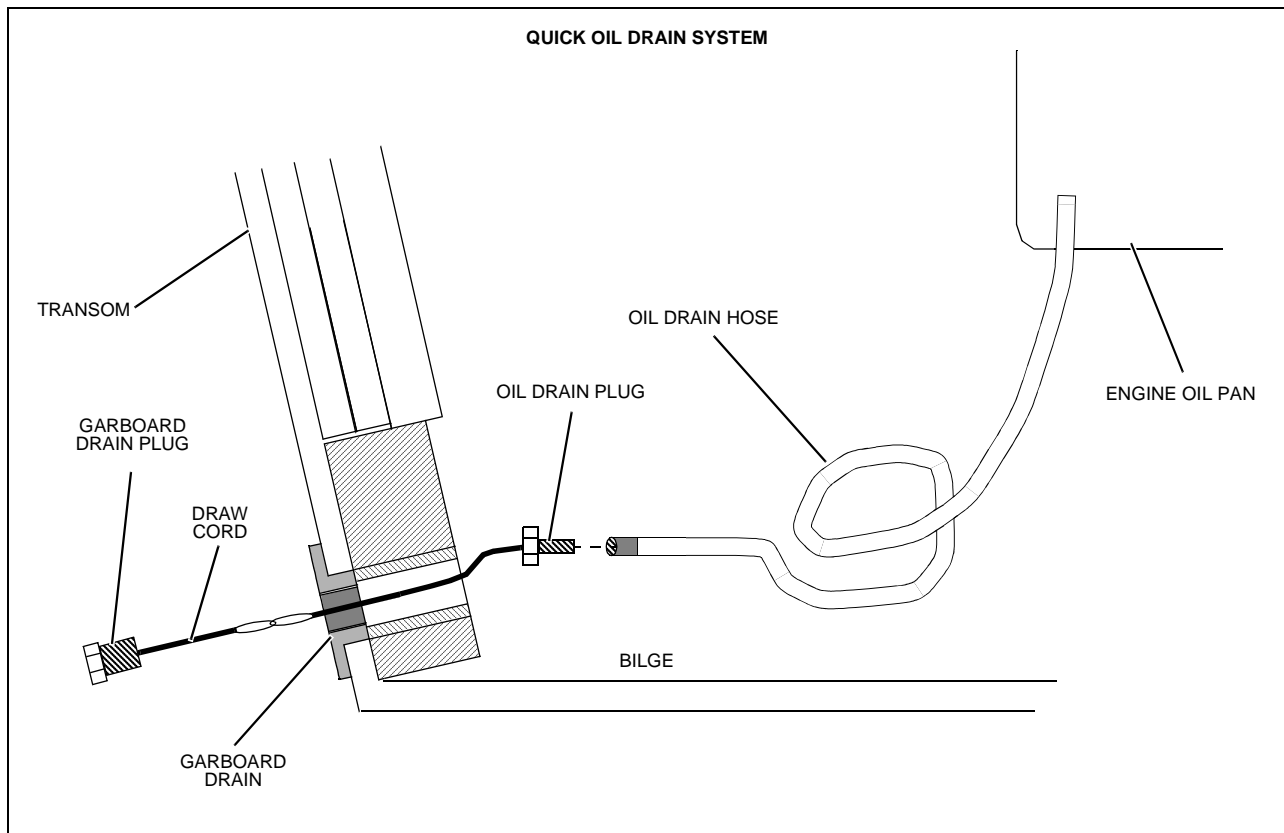

To drain the engine oil:

1. Remove the boat from the water.
2. Unscrew the garboard drain plug.
3. Pull the draw cord until the oil drain plug and the oil drain hose slide out of the garboard drain.
4. Place the end of the oil drain hose into a suitable container.
5. Unscrew the oil drain plug and drain the engine oil.
6. Replace the oil drain plug.
7. Push the drain hose back into the bilge.
8. Replace the garboard drain plug.

Always dispose of waste oil in accordance with local regulations.

Chapter 5: Controls

Steering

- Refer to the engine manual for steering system details.

Shift/Throttle Lever

 WARNING!
<i>LOSS OF CONTROL HAZARD!</i>
Improper maintenance of shift/throttle hardware may cause a sudden loss of control!

- Carefully read and understand *all* of the information about the shift/throttle in the *Sport Boat Owner's Manual*.
- Also, read and understand the shifter/throttle and engine manuals.

Power Trim and Tilt

- The stern drive on your boat is equipped with power trim and tilt.
- Trim and tilt instructions are provided in the engine operation manual and the shifter/throttle manual.

Gauges

Cleaning Gauges

 CAUTION
<i>PRODUCT or PROPERTY DAMAGE HAZARD!</i>
<ul style="list-style-type: none">• Use only mild soap and water to clean the gauge lenses and bezels.• Use of other cleaners, including common window cleaning solutions, may cause the lenses to crack.• Lenses cracked in this manner <i>will not</i> be covered by our warranty.

Gauge Fogging

- Moisture may occasionally find its way into the gauges causing lens fogging.
- Turning *On* the gauge lights will help dry the lenses.
- Fogging *will not* harm the gauges.

Radio Transmission Interference

VHF or other radio transmissions may cause brief erratic readings on the tachometer. This *will not* damage this gauge or affect its accuracy when *not* transmitting.

Fuel Gauge

It is normal for the pointer on your fuel gauge to bounce as fuel sloshes back and forth in the fuel tank.

Chapter 6: Plumbing

Drain Systems

Deck Drains

- Water on the deck is drained overboard through the deck drains.
- Keep the deck drains free of debris.

Bilge Pump

NOTICE

Discharge of oil, oil waste or fuel into navigable waters is prohibited by law. Violators are subject to legal action by the local authorities.

- Your boat is equipped with a bilge pump for pumping water out of the bilge.
- The bilge pump is controlled by a switch at the helm.

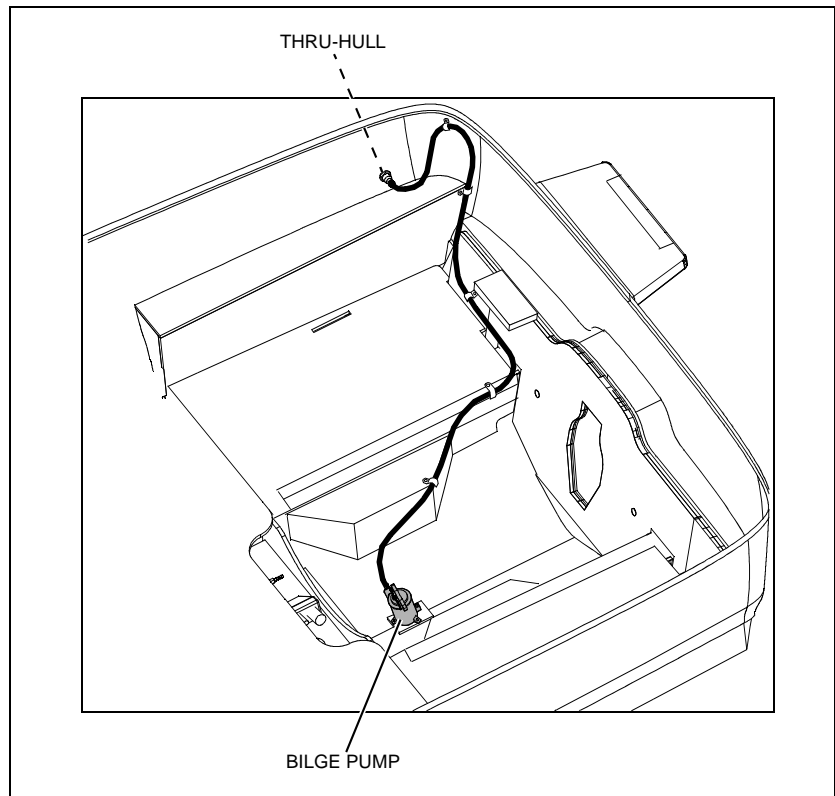

Bilge Pump Testing

- The bilge pump is critical to the safety of your boat.
- Check the bilge pump often to make sure it is working.

Test the pump as follows:

1. Turn **On** the bilge pump switch at the helm.
2. Any water in the bilge should pump overboard.
 - If the pump motor is running, but **not** pumping, inspect the discharge hose for a kink or collapsed area.
 - If no problems are found, check the bilge pump housing for clogging debris as follows:

1. Remove the power cartridge:
 - a. Lift the tab while rotating the fins counter-clockwise.
 - b. Lift out the power cartridge.
 - c. Clear the outer housing of debris.
2. Reinstall the power cartridge:
 - a. Make sure the "O" ring is properly seated.
 - b. Coat the "O" ring with a light film of vegetable or mineral oil.
 - c. Align the cams on either side of the power cartridge with the two slots on the outer housing
 - d. Press the power cartridge into the housing while twisting clockwise
3. Check the reinstallation by trying to twist the fins counter-clockwise without lifting the tab; the cartridge should stay in place.

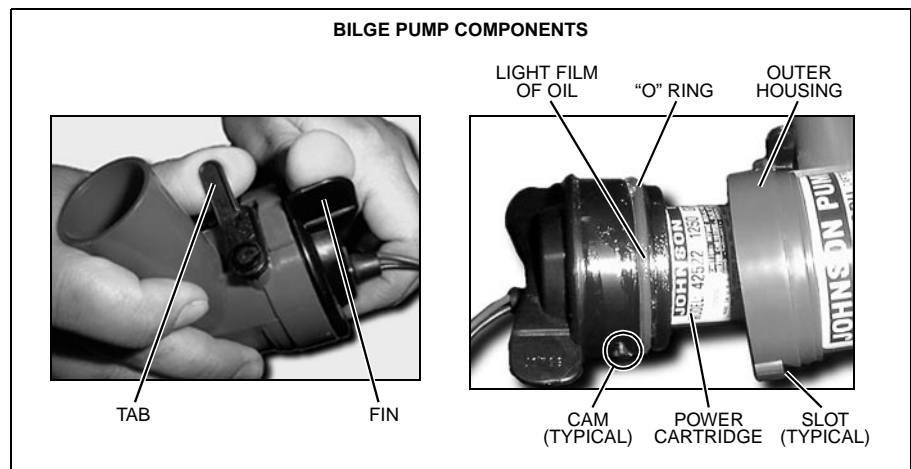

Seawater System (If Equipped)

Seacock

CAUTION!

SYSTEM DAMAGE HAZARD!

- ***Before*** using a seawater intake system, make sure that the system's seacock is in the *Open* position before the system is started and keep the seacock *Open* until the system is shut *Off*.
- ***Close*** the seacock whenever the system will *not* be used for long periods of time.

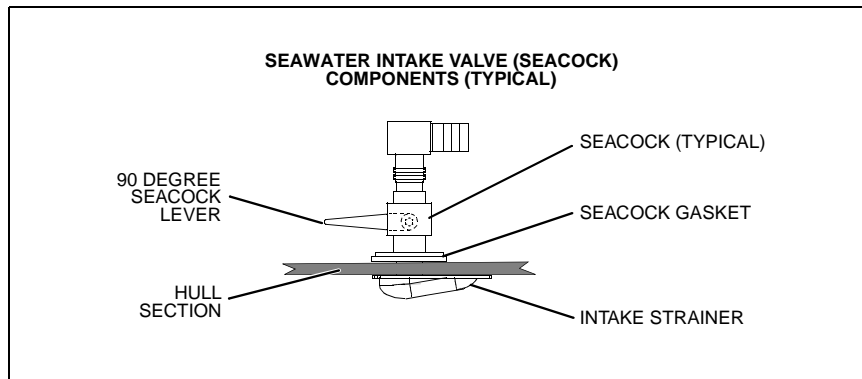

A seacock is a valve, controlled by a 90° lever, used to manage the intake of seawater through the hull and below the water line. The seawater intake system used on your boat is for the Live Well system (if equipped)

Before using this system, make sure that the system's seacock is *Open* and remains *Open* until the system is shut *Off*.

Portable Toilet (If Equipped)

Your boat may feature a portable toilet. Read and follow the manufacturer's operating instructions ***before*** using your portable toilet.

Baitwell System (194 Only)

NOTICE

The baitwell pump should be shut *Off* while underway at planing speeds.

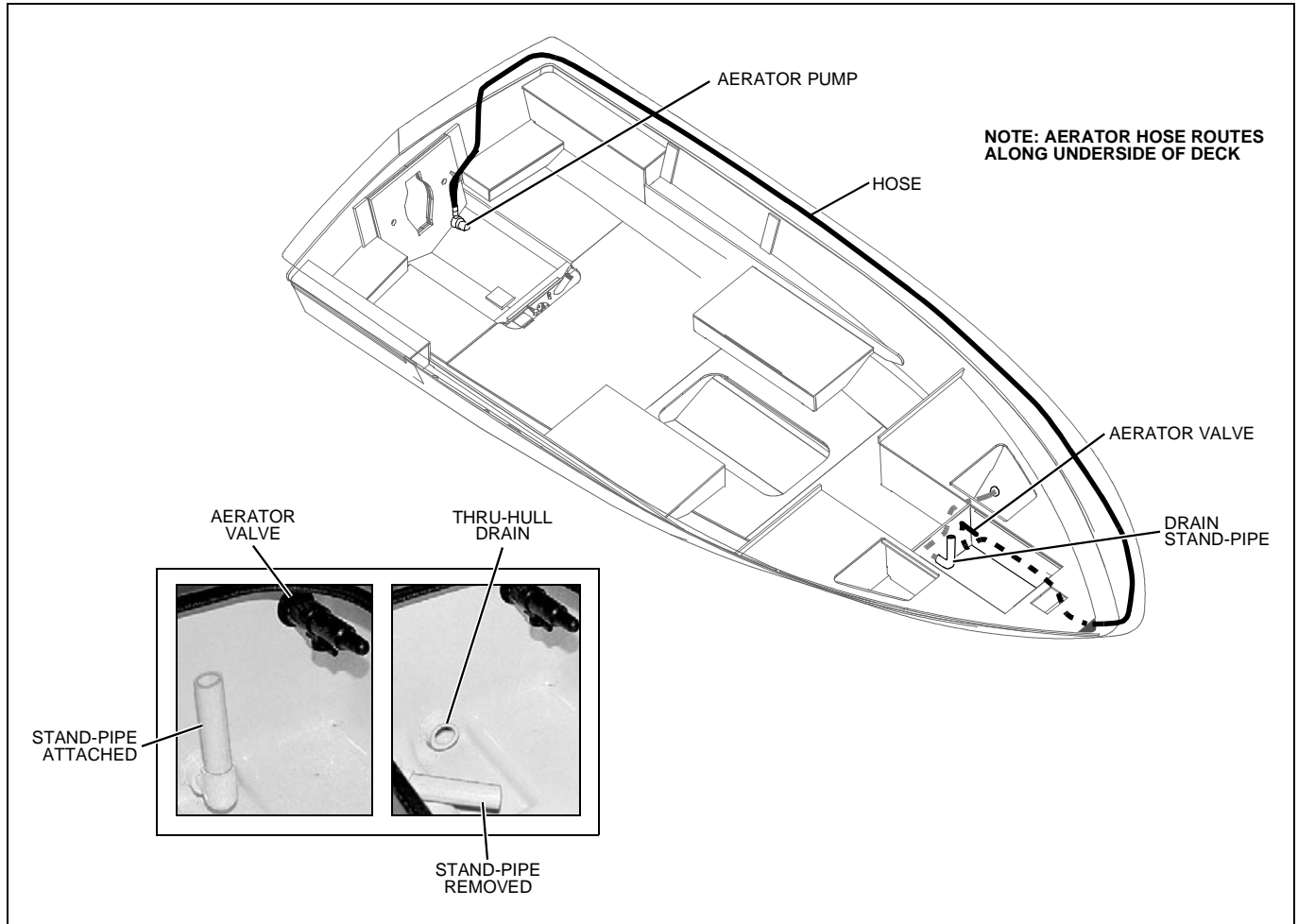

- The switch for the baitwell is located on the main dash panel.
- This switch turns **On** the aerator that pumps a continuous supply of fresh water into the baitwell.
- The overflow is automatically drained overboard.
- Check the baitwell system often to make sure that it is pumping adequate amounts of water.
- If there appears to be a problem, check the system for weeds or other debris.
- Completely drain the baitwell by removing the drain stand-pipe.

Chapter 7: Deck Equipment

Cleats and Tow Eyes

 WARNING!
<p><i>PERSONAL INJURY and /or PRODUCT or PROPERTY DAMAGE HAZARD!</i></p> <ul style="list-style-type: none"> • NEVER lift the boat using the bow and stern eyes or the cleats.

Carefully read the section on towing in the *Sport Boat Owner's Manual* before:

- Towing anything behind the boat.
- Being towed by another vessel.

Ski Tow Ring

 WARNING!
<p><i>PERSONAL INJURY and /or PRODUCT or PROPERTY DAMAGE HAZARD!</i></p> <p>Failure to follow these guidelines can result in injury or death:</p> <ul style="list-style-type: none"> • Only tow water skis, wakeboards, or recreational towables. • Do not tow parasails, kites, or other boats. • Do not tow more than two persons at one time. • Use caution with skier in tow as tow rope may snap back into cockpit when released.

Your boat has a ski tow ring. Attach tow rope as shown in the photo.

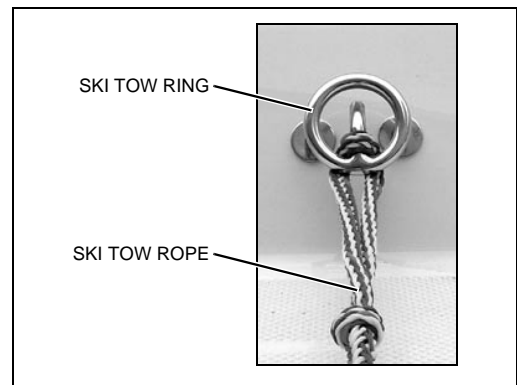

Pre-rigging For Trolling Motor (194 Only)

- The 194 features a trolling motor connection at the bow and a reinforced deck area designed to support a trolling motor mounting bracket.
- Contact your selling dealer for a list of compatible equipment and installation instructions.
- The trolling motor system can be used safely with either a 12V or a 24V motor.

Canvas (If Equipped)

CAUTION!

PRODUCT or PROPERTY DAMAGE HAZARD!

- Canvas tops are *not* designed to withstand speeds over 45 MPH.
- Take down and securely stow the canvas top *before* transporting your boat by road.

195 & 192 Canvas Top (If Equipped)

Installing the Canvas

1. Insert the end eyes of the main bow (A) into the forward hinges (B) and secure with the pins.
 2. Unfold the canvas top and snap the front edge of the top (C) to the top of the windshield frame.
 3. Insert the end eyes of the aft braces (D) into the aft hinges (E) and secure with the pins.
 4. Align the secondary bow (F) with the center seam (G) of the canvas by loosening or tightening the top straps (H).
- Since the jawslides (I) were preset during manufacturing they should *not* need to be adjusted.
 - However, if you think the jawslides need to be adjusted, obtain the correct measurements from your selling dealer.

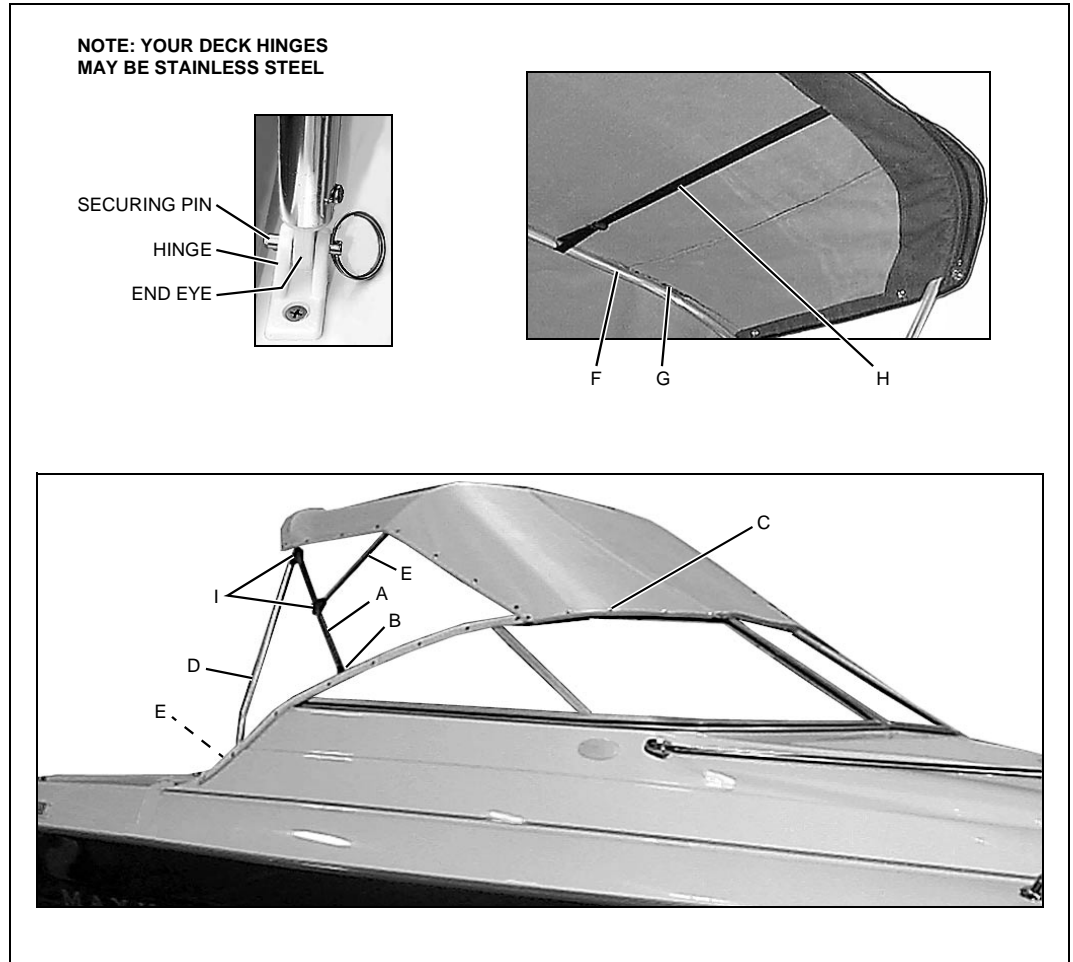

194 Canvas Top (If Equipped)

Installing the Canvas

1. Insert the end eyes of the main bow (A) into the forward deck hinges (B) and secure with the pins.
 2. Unfold the canvas top and snap the front edge of the top (C) to the top of the windshield frame.
 3. Insert the end eyes of the aft braces (D) into the aft deck hinges (E) and secure with the pins.
 4. Align the secondary bow (F) with the center seam (G) of the canvas by loosening or tightening the top straps (H).
- Since the jawslides (I) were preset during manufacturing they should **not** need to be adjusted.
 - However, if you think the jawslides need to be adjusted, obtain the correct measurements from your selling dealer.

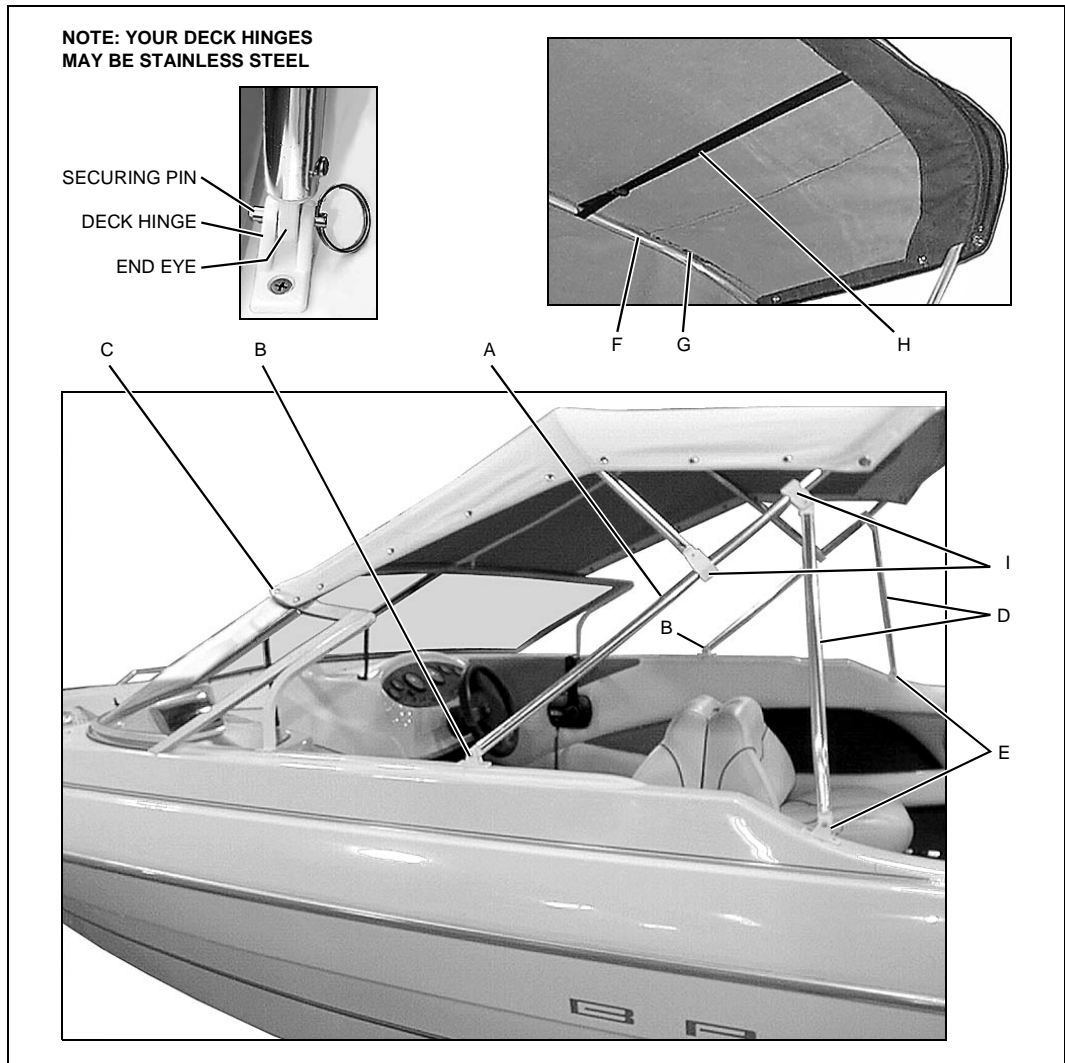

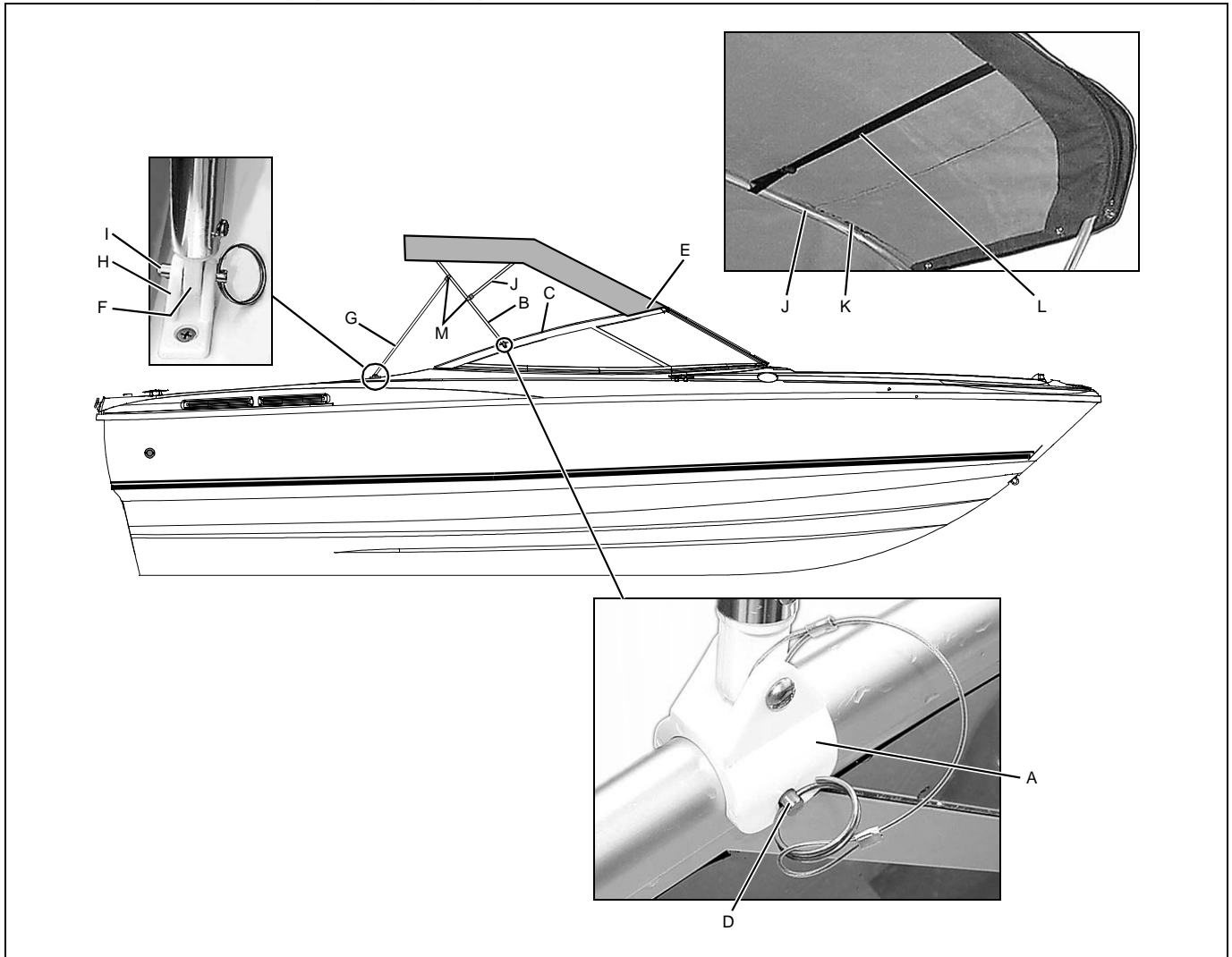
215 & 210 Canvas Top (If Equipped)**Installing the Canvas**

1. Slide the swivel ends (A) of the main bow (B) over the side windshield frames (C) and insert the pins (D).
2. Unfold the canvas top and snap the front edge of the top (E) to the windshield frame.
3. Insert the end eyes (F) of the aft braces (G) into the deck hinges (H) and insert the pins (I).
4. Align the secondary bow (J) with the center seam (K) of the canvas by loosening or tightening the top straps (L).
 - Since the jawslides (I) were preset during manufacturing they should **not** need to be adjusted.
 - However, if you think the jawslides need to be adjusted, obtain the correct measurements from your selling dealer.

195 & 194 Bimini Top (If Equipped)

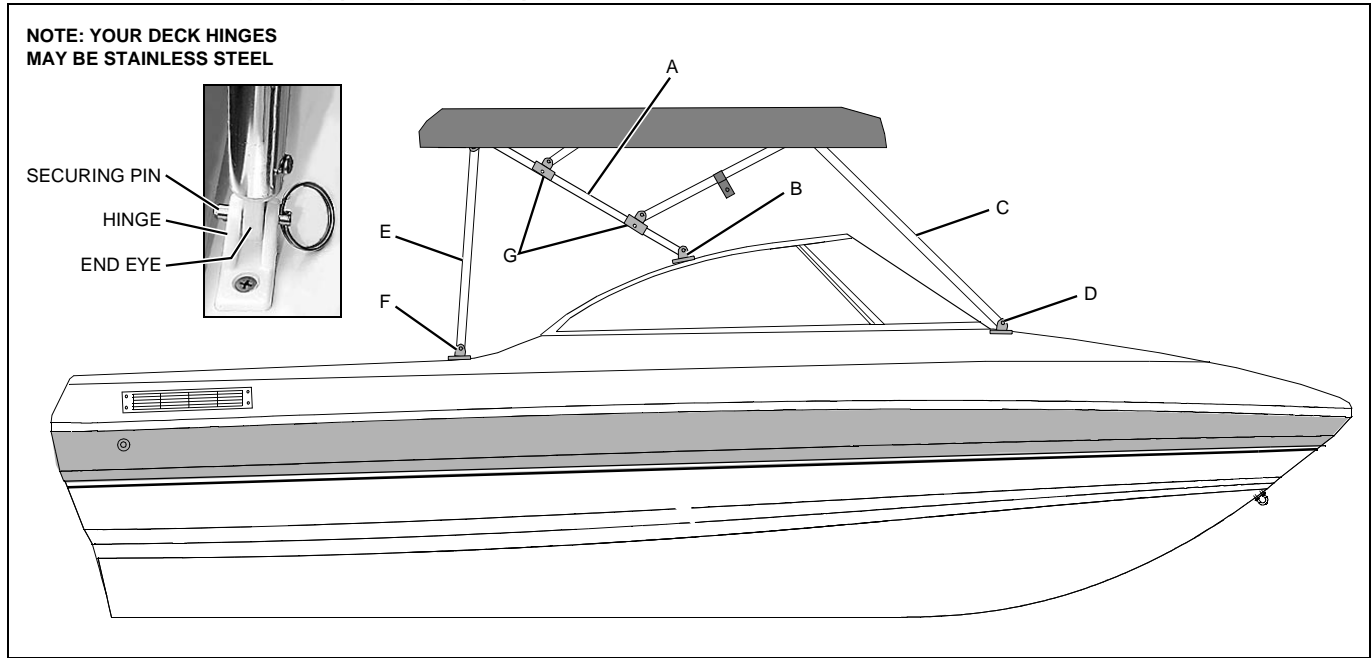

Installing the Bimini Top

1. Insert the end eyes of the main bow (A) into the mid hinges (B) and secure with the pins.
2. Unfold the canvas and insert the end eyes of the forward braces (C) into the forward hinges (D) and secure with the pins.
3. Insert the end eyes of the aft braces (E) into the aft hinges (F) and insert the pins.
 - Since the jawslides (G) were preset during manufacturing they should *not* need to be adjusted.
 - However, if you think the jawslides need to be adjusted, obtain the correct measurements from your selling dealer.

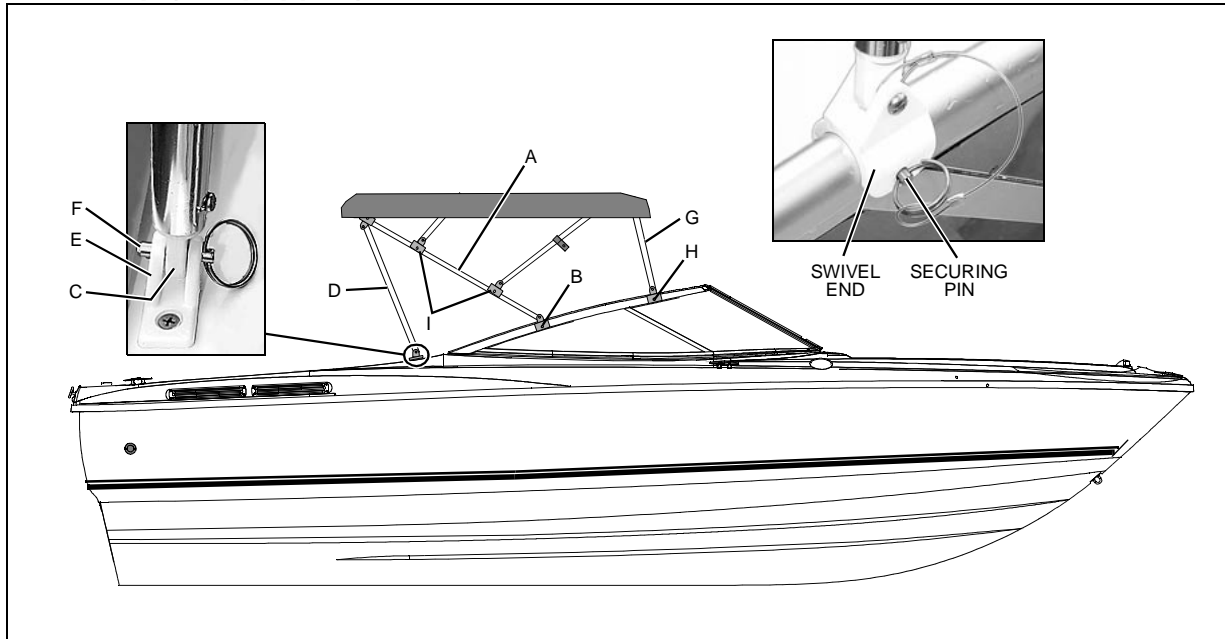
215 Bimini Top (If Equipped)***Installing the Bimini Top***

1. Slide the swivel ends of the main bow (A) over the aft holes (B) in the side windshield frames and secure with the pins.
2. Insert the end eyes (C) of the aft braces (D) into the deck hinges (E) and secure it with the pins (F).
3. Unfold the canvas and slide the swivel ends of the forward braces (G) over the forward holes (H) in the side windshield frames and secure with the pins.
 - Since the jawslides (I) were preset during manufacturing they should **not** need to be adjusted.
 - However, if you think the jawslides need to be adjusted, obtain the correct measurements from your selling dealer.

Chapter 8: Entertainment Systems

Audio System

NOTICE

AM radio reception may be impaired anytime the engine is running.

Read the audio system instructions *before* using the system.

Chapter 9: Convertible Seats, Beds, & Tables

Sleeper Seats (If Equipped)

- The sleeper seats can be adjusted fore and aft in the upright, operating position.
- The seat bottoms adjust into backrests when the seats are in the lounge position.

Operating Positions

To slide the seat forward:

1. Lift the forward seat at point (A).
2. Push down on the forward seat at point (B) and pull the seat forward.
3. Lock the forward seat into the desired position by pushing down at point (A).
4. Lift the aft seat at point (C).
5. Push down on the aft seat at point (D) and push the seat forward until the aft seat back is flush against the forward seat back.
6. Lock the aft seat into position by pushing down at point (C).

To slide the seat aft, repeat the steps above, but start with the aft seat.

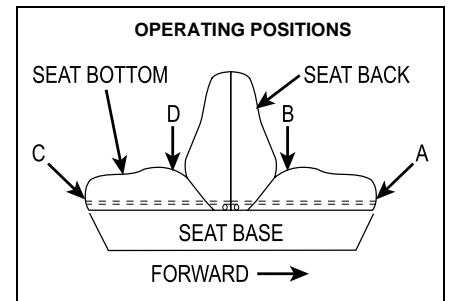

Lounge positions

To adjust into the flat lounge position:

1. Lift the forward seat at point (A).
2. Push down on the forward seat at point (B) and pull the seat forward until the seat back and bottom are flat.
3. Lift the aft seat at point (C).
4. Push down on the aft seat at point (D) and pull the seat aft until the seat back and bottom are flat.

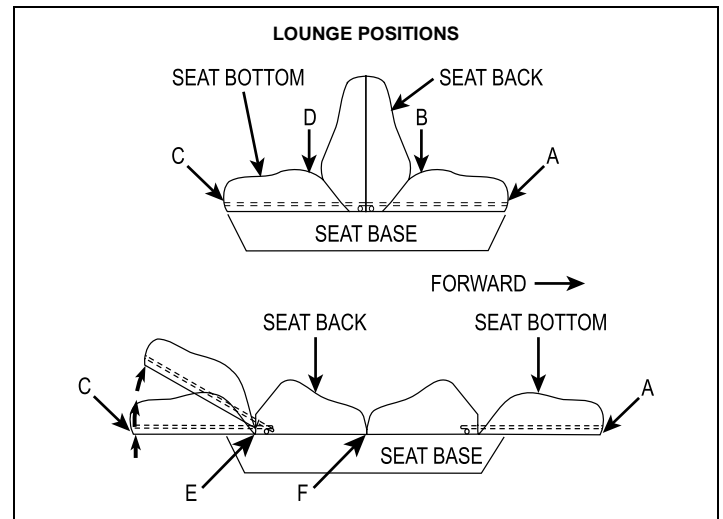

To adjust into the chaise lounge position:

1. Lift up on the forward or aft seat bottom at point (A or C) and push the seat bottom down into the locked position.
2. To lower the seat bottom, lift the seat at point (A or C). Drop the seat bottom flat while holding the seat down at point (E).

To return the seats to the operating position:

1. Lift the seat backs at point (F) and push down on the back edge of the seat bottom (B) and then seat bottom (D).
2. Push the seat bottoms towards the center of the seat until the seat backs are flush against each other and locked into place.

Jump Seat To Sunlounge Conversion

⚠ **DANGER!**

PERSONAL SAFETY HAZARD!

- **DO NOT** allow anyone to ride on the aft sunlounge cushions while underway or when the engine is running.
- **Occupying the aft sunlounge while underway is especially hazardous and WILL cause personal injury or death.**

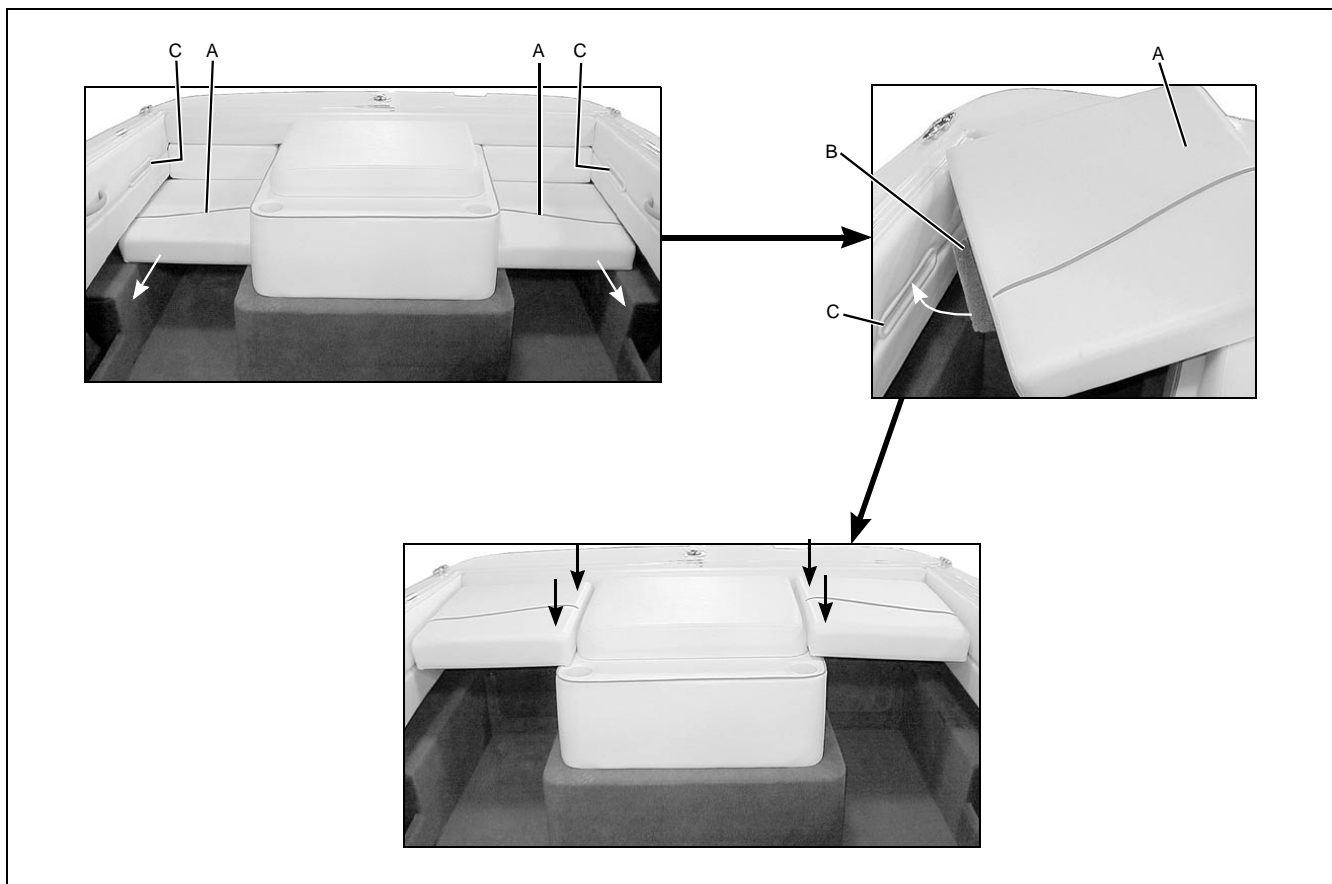

1. Remove the jump seats (A) by sliding them forward.
2. Slide the lounge support inserts (B) into the lounge support slots (C).
3. Press down firmly on the inboard side of each jump seat until they rest firmly on the motorbox ledges.

Removable Fishing Seats (194 Only)

! DANGER!

 **PERSONAL SAFETY HAZARD!**

- **DO NOT** allow anyone to ride on parts of the boat *not* designated for such use.
- Sitting on the fishing seat while underway is especially hazardous and **WILL** cause personal injury or death.

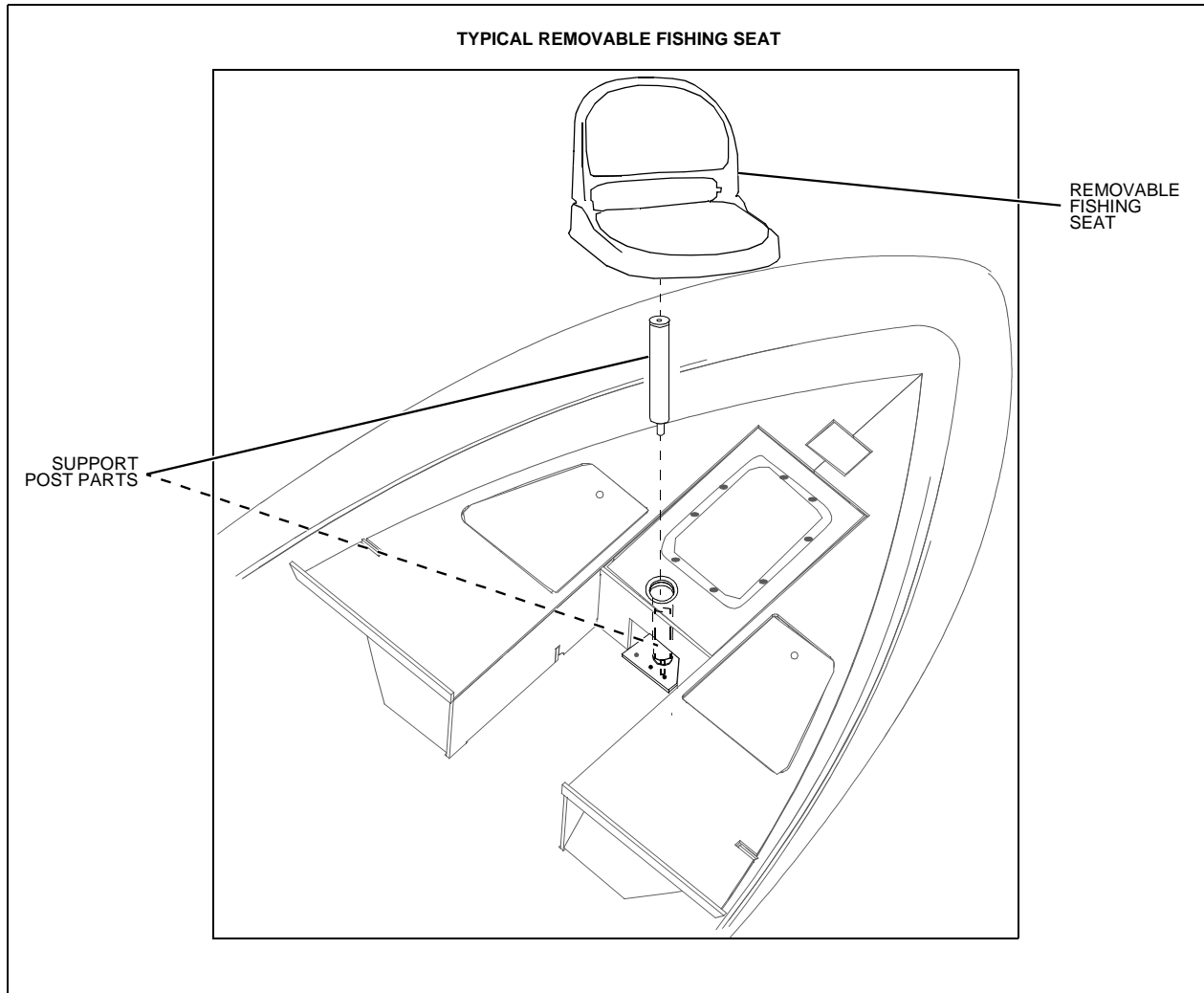

All fishing seats should be removed and stowed in a safe and secure area while underway or when trailering your boat.

Chapter 10: Lights

Care and Maintenance

All of the lights installed on your boat are of top quality, but you should be aware that failure may periodically occur for a variety of reasons:

1. There may be a blown fuse - *replace the fuse.*
2. The bulb may be burned out - *carry spare bulbs for replacement.*
3. A wire may be damaged or may have come loose - *repair as required.*
4. The bulb base may be corroded - *clean the base and coat it with non-conductive electrical lubricant.*



Navigation Lights



Read and understand the navigation light section of *Sport Boat Owner's Manual*.





Chapter 11: Electrical System

⚠ DANGER!

   **EXTREME FIRE, SHOCK & EXPLOSION HAZARD!**

- To minimize the risks of fire and explosion, **NEVER** install knife switches or other arcing devices in the fuel compartments.
- **NEVER** substitute automotive parts for marine parts. Electrical, ignition and fuel system parts were designed and manufactured to comply with rules and regulations that minimize risks of fire and explosion.
- **DO NOT** modify the electrical systems or relevant drawings.
- Have qualified personnel install batteries and/or perform electrical system maintenance.

⚠ WARNING!

     **FIRE & EXPLOSION HAZARD!**

- Visually and by smell (sniff test), check the engine and fuel compartments for fumes or accumulation of fuel.
- Minimize the danger of fire and explosion by *not* exposing the batteries to open flame or sparks. **NEVER** smoke anywhere near the batteries.

⚠ CAUTION!

 **SHOCK & ELECTRICAL SYSTEM DAMAGE HAZARD!**

NEVER disconnect the battery cables while the engine is running since it can cause damage to your boat's electrical system components.

NOTICE

Electrical connections are prone to corrosion. To reduce corrosion caused electrical problems, keep *all* electrical connections clean and apply a spray-on protectant that is designed to protect connections from corrosion.

12-Volt DC System

Battery

The battery supplies electricity for lights, accessories, and engine starting.

The Electrical section of Chapter 8, in the *Sport Boat Owner's Manual*, provides battery, care and maintenance instructions.

Fuses and Circuit Breakers

- Fuses for the engine and main accessory power are on the fuse block behind the dash.
- Some equipment may have secondary fuse protection at the unit, or at the battery.
- Electronics power is provided at the helm station.

Alternator

The engine alternator will keep the battery properly charged when running at cruising speeds.

12-Volt Accessory Outlet

 CAUTION!
<i>DO NOT</i> use the 12-volt accessory outlet with a cigarette or cigar lighter. High temperatures may melt the outlet.

- Your boat is equipped with a 12-volt accessory outlet at the helm.
- The outlet can be used with any 12-volt device which draws 15 amps or less.
- The 12-volt accessory outlet is protected by 10 amp fuse on the main fuse block behind the dash.

Electrical Routings

192 Deck Electrical Harness

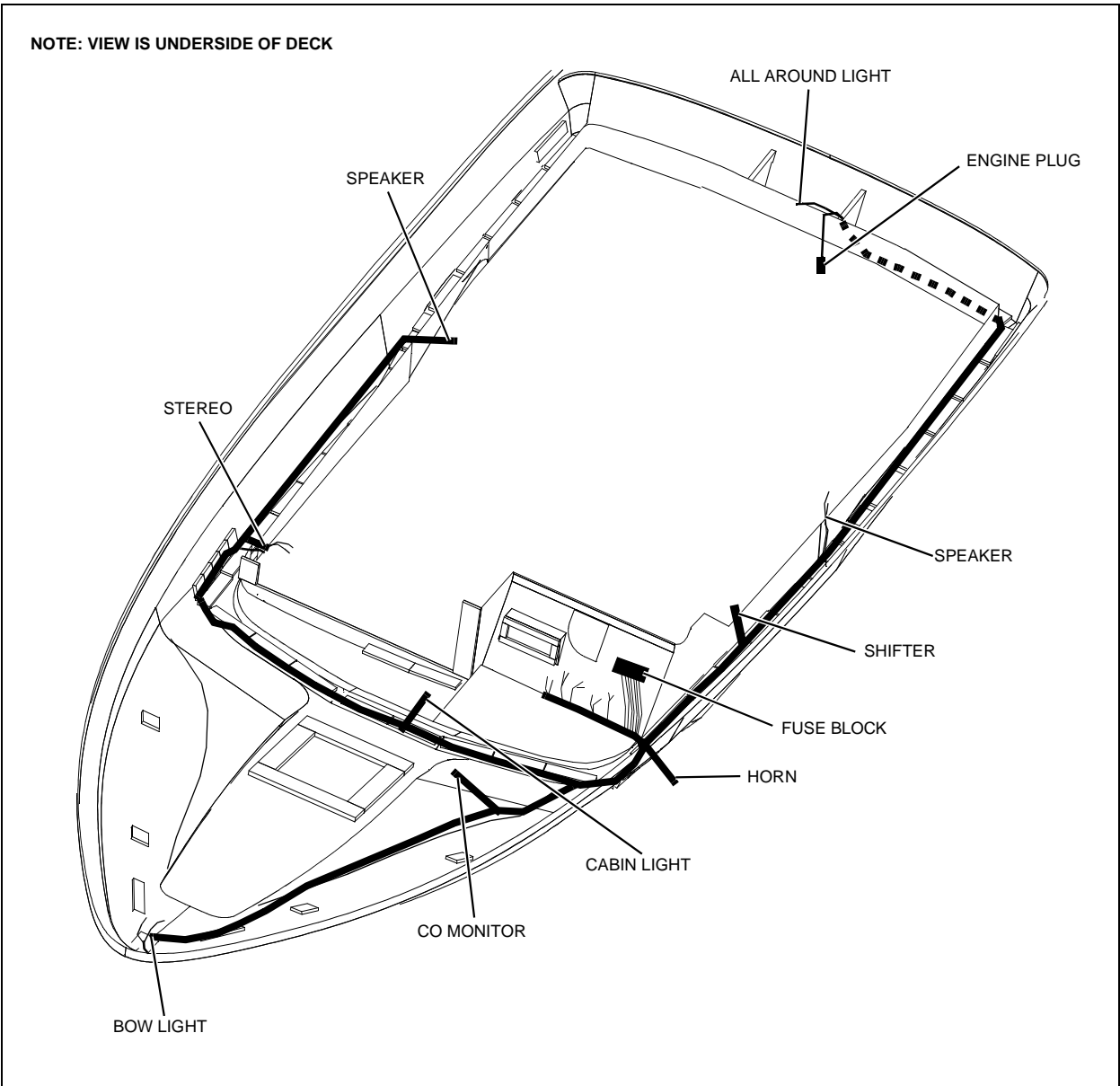

194 Deck Electrical Harness

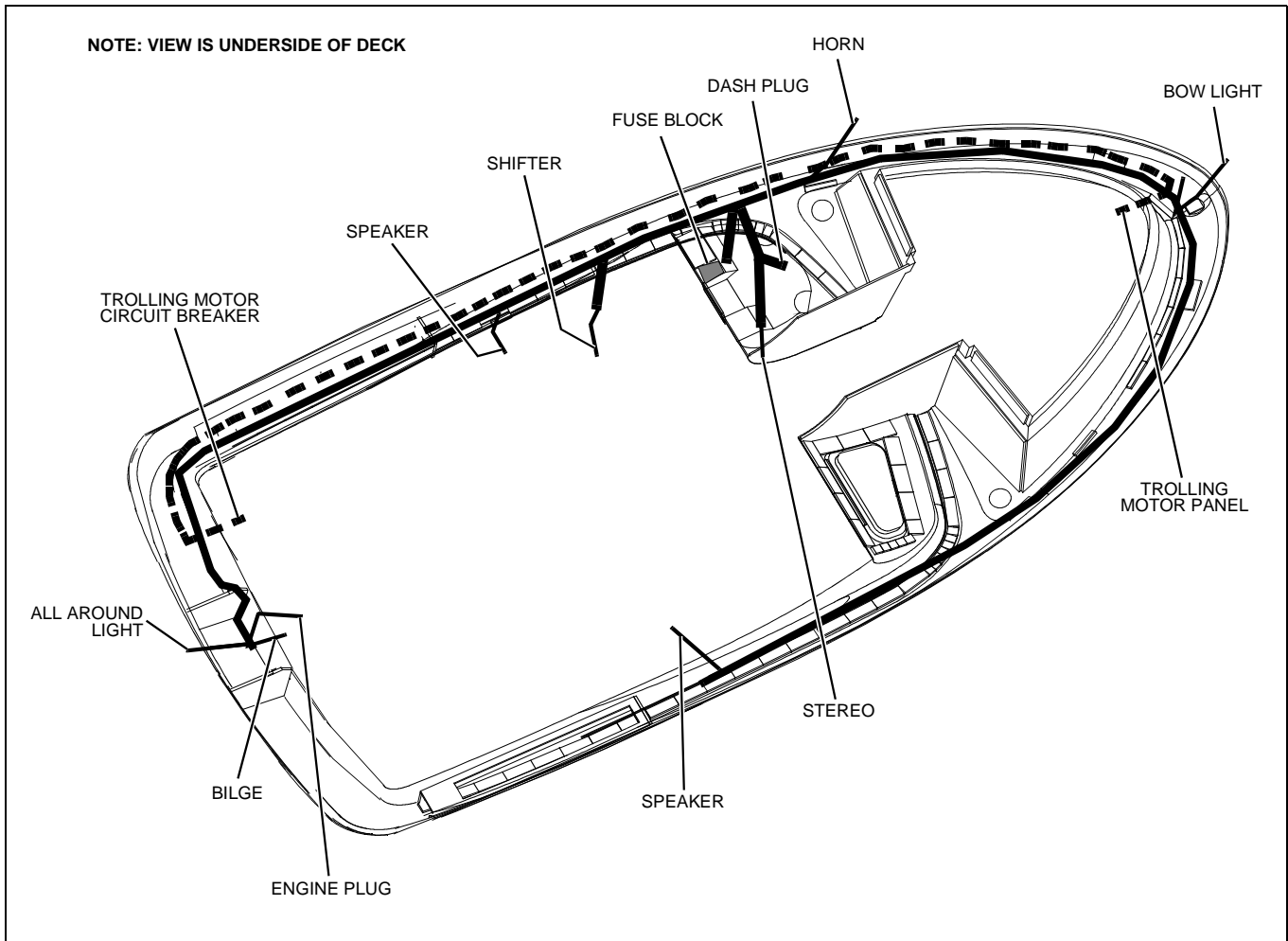

195 Deck Electrical Harness

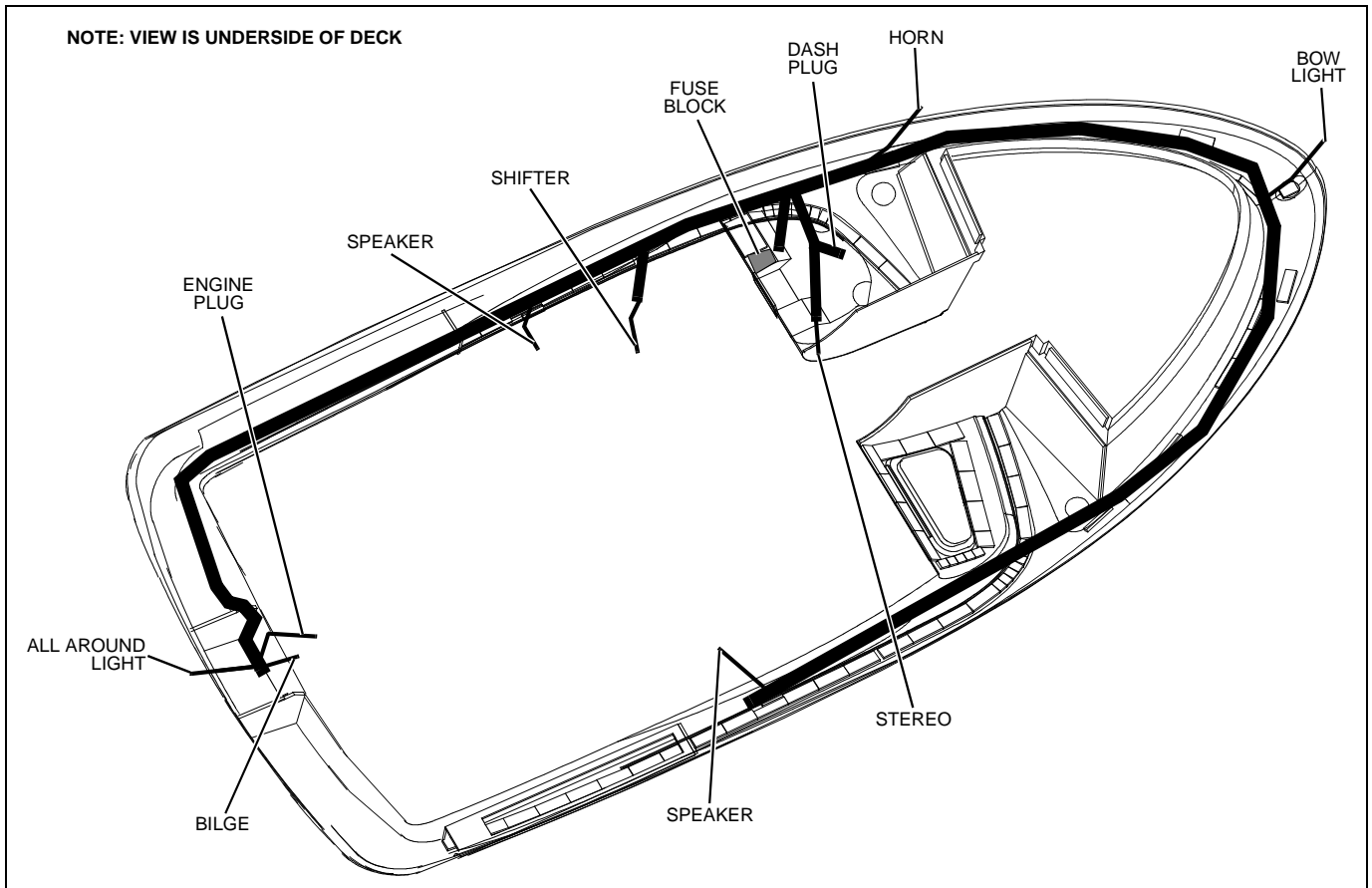

210 Deck Electrical Harness

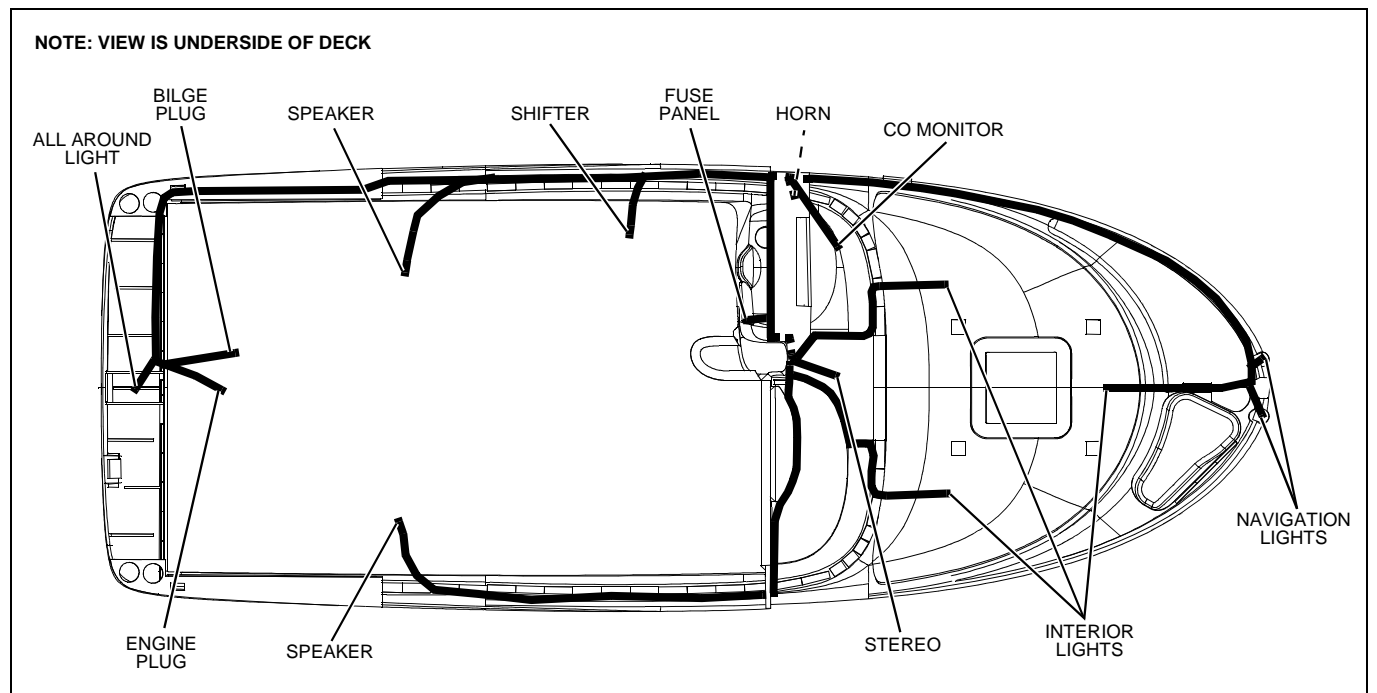

215 Deck Electrical Harness

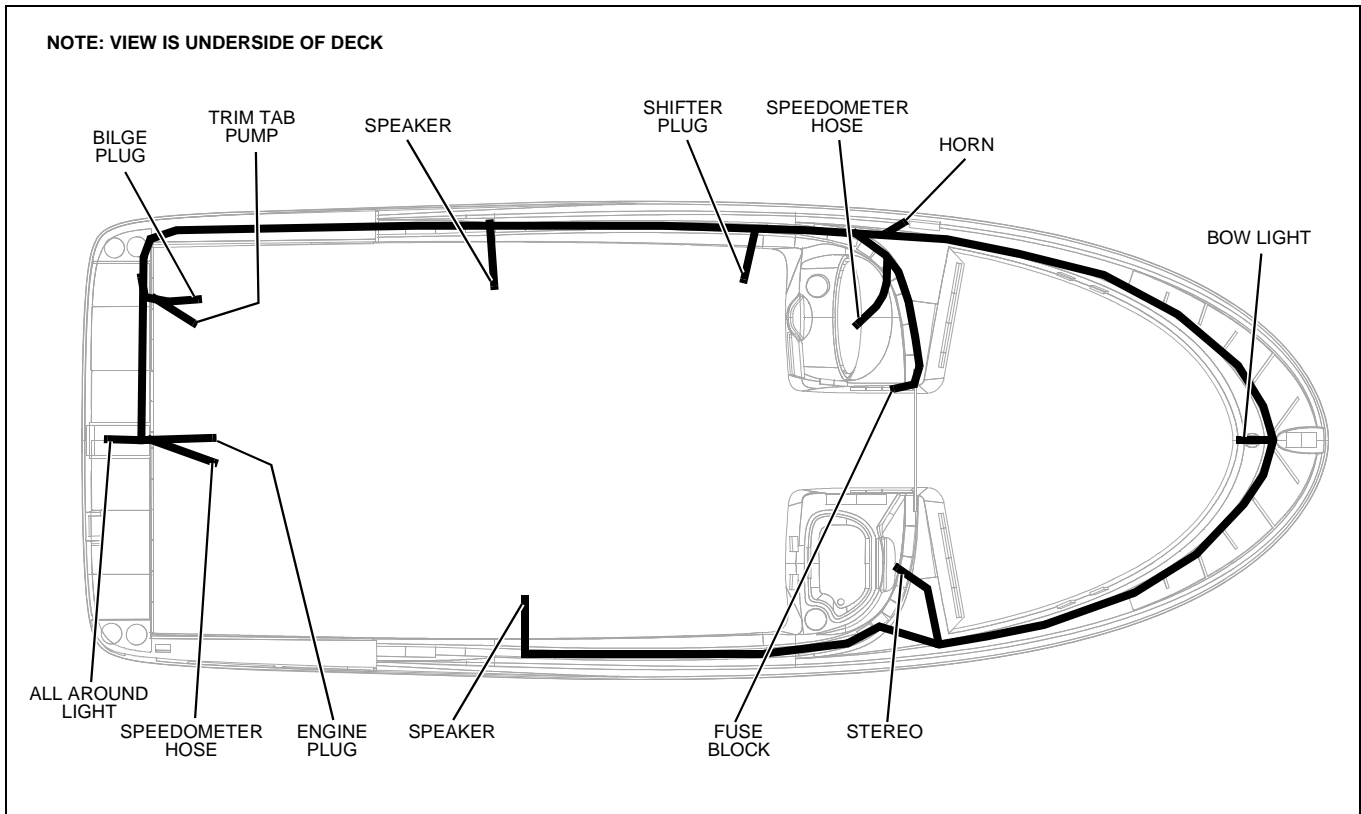

195, 192 & 194 Hull Electrical Harness

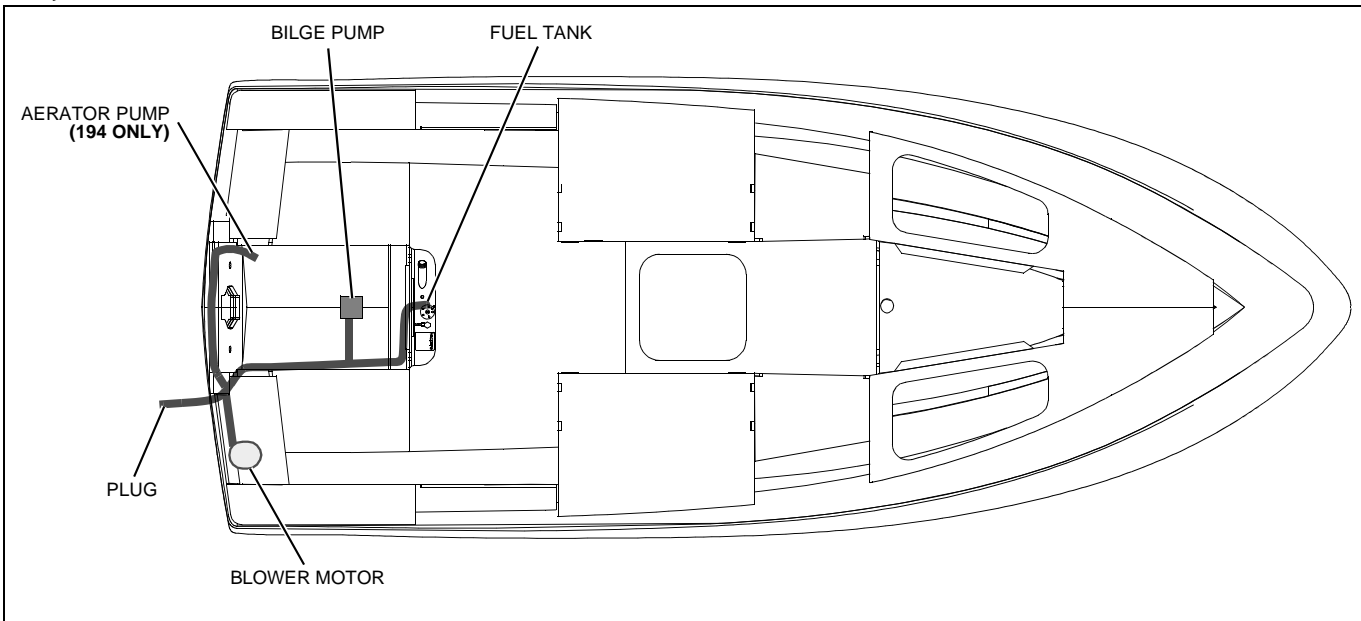

210 & 215 Hull Electrical Harness

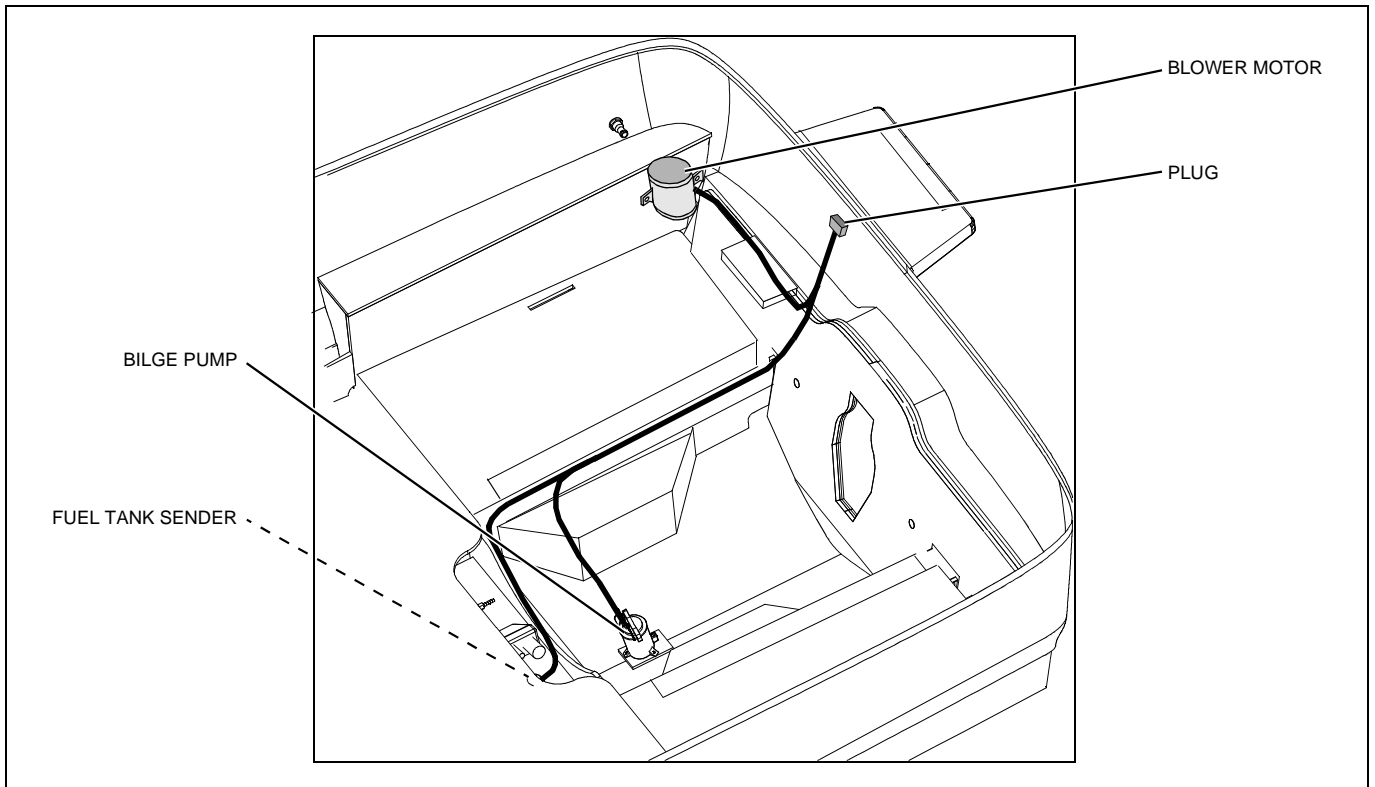

210 & 215 Battery Cable Harness

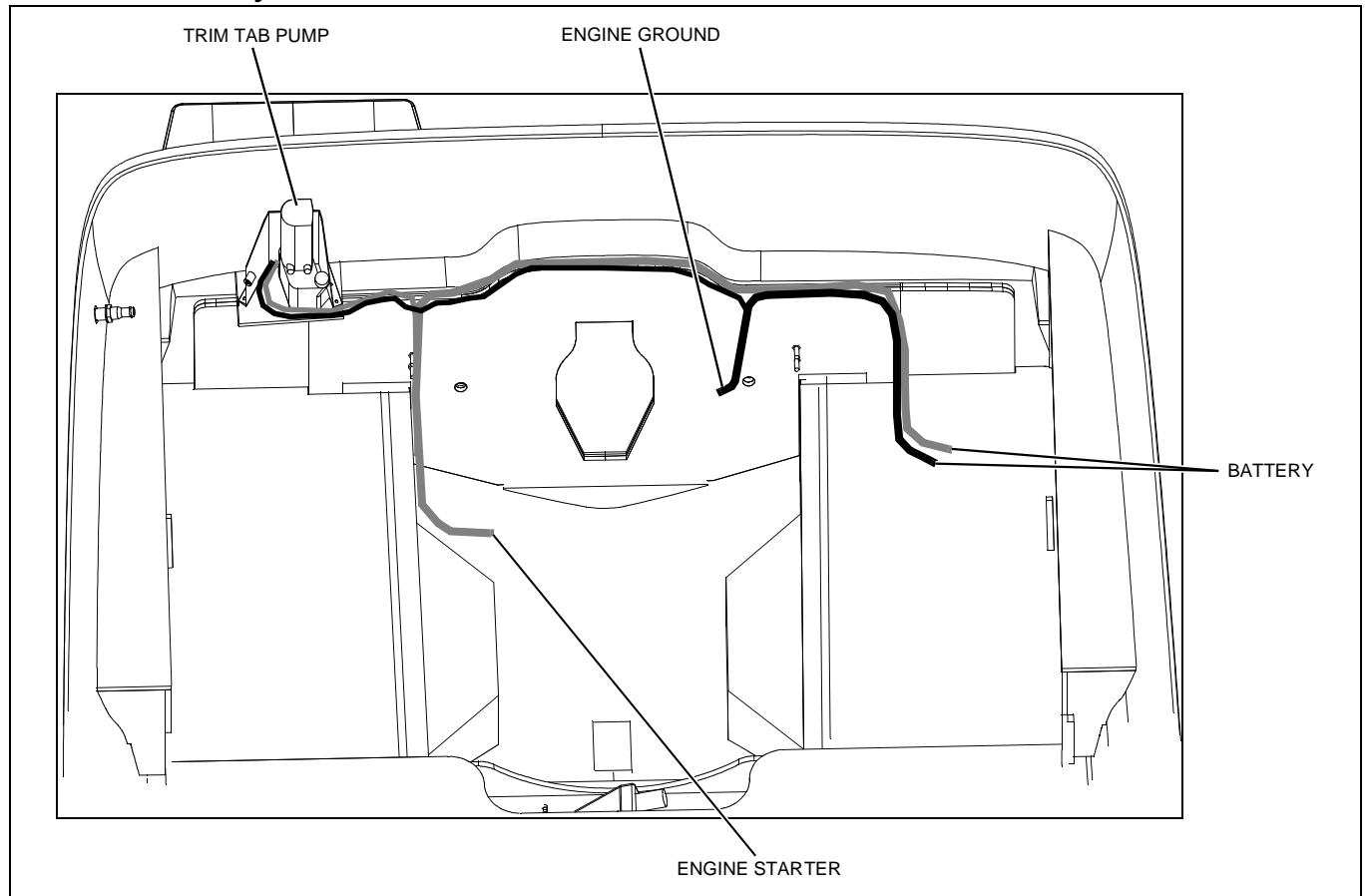

Wiring Diagram

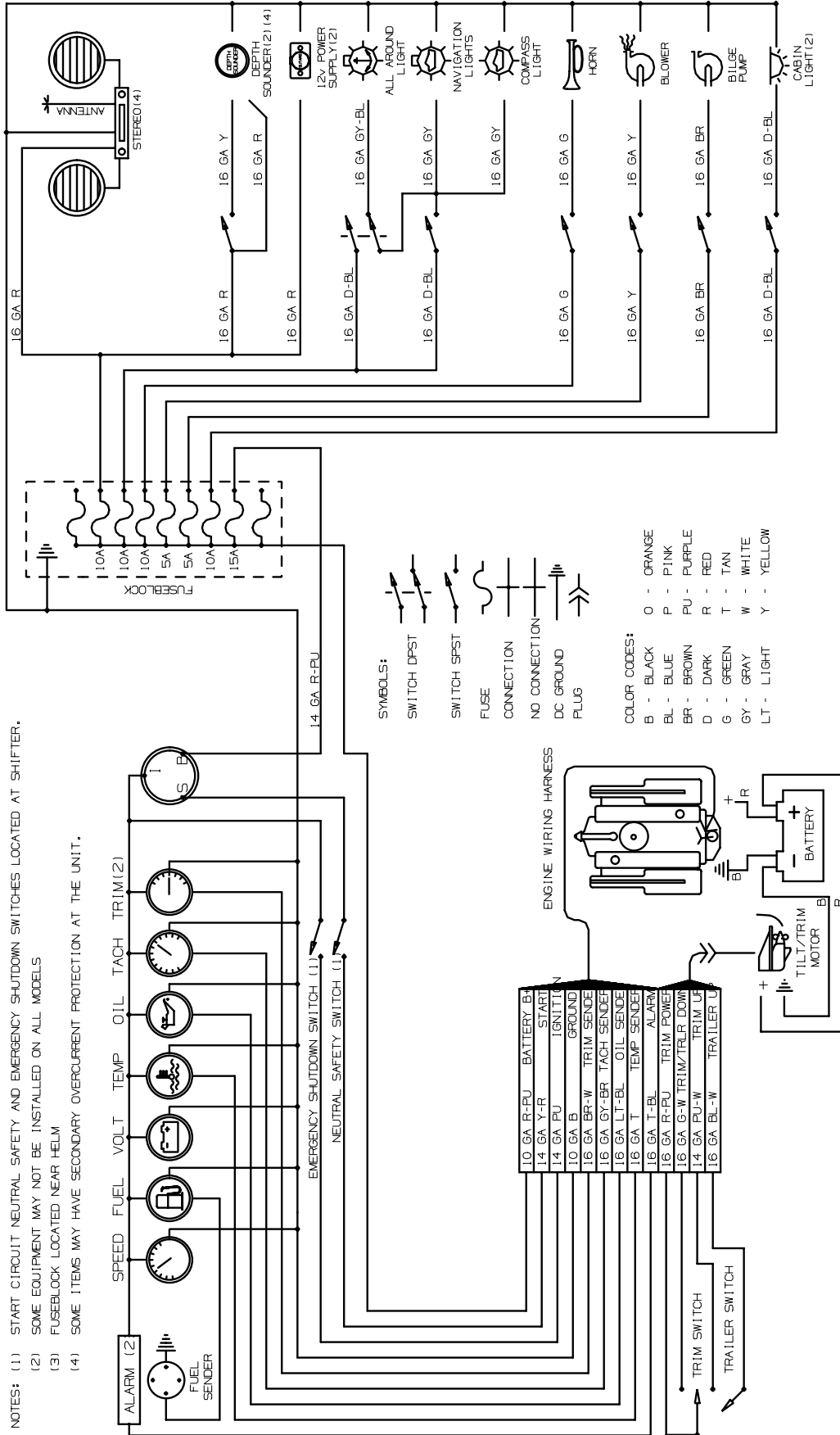

Important Records

Selling Dealer

Name Of Dealership

Address

Phone/FAX/E-mail

Sales Manager

Service Manager

Engine

Manufacturer

Model Name/Number

Engine Serial Number

Oil Type/SAE

Quarts per Engine

Filter Type

Propeller

Manufacturer

Pitch

Model Number

Key Numbers

Ignition

Other

Electronics

Manufacturer

Model Name/Number

Serial Number

Manufacturer

Model Name/Number

Serial Number

Manufacturer

Model Name/Number

Serial Number

Manufacturer

Model Name/Number

Serial Number

Float Plan

Before going boating, fill out a copy of this float plan (or similar) and leave it with a *reliable* person whom you can depend on to contact the Coast Guard or other rescue organization, if you do not return as scheduled.

Description of Boat

Registration/Documentation Number		
Length	Make	Type
Hull Color		Trim Color
Fuel Capacity	Engine Type	Number of Engines
Distinguishing Features		
Distinguishing Features		

Operator of Boat

Full Name		
Male or Female	Age	Health
Address		
Address		
Phone/FAX/E-mail		
Operator's Experience		

Persons on Board

Full Name		
Age	Health	Phone Number
Full Name		
Age	Health	Phone Number
Full Name		
Age	Health	Phone Number
Full Name		
Age	Health	Phone Number
Full Name		
Age	Health	Phone Number

Survival Equipment

Marine Radio (Yes/No)	Type	Frequencies
Number of PFDs	Flares (Yes/No)	Mirror (yes or no)
Smoke Signals (Yes/No)	Flashlight (Yes/No)	Food (Yes/No)
Water (Yes/No)	Anchor (Yes/No)	Raft/Dinghy (Yes/No)
Paddles (Yes/No)	EPIRB (Yes/No)	Other
Other	Other	Other

Vehicle Description

Make	Model
Color	License Number
Where is the Vehicle Parked?	

Trip Expectations

Departing From	
Departure Date	Departure Time
Stopover 1	
Arrive No Later Than: Date	Arrive No Later Than: Time
Stopover 2	
Arrive No Later Than: Date	Arrive No Later Than: Time
Stopover 3	
Arrive No Later Than: Date	Arrive No Later Than: Time
Stopover 4	
Arrive No Later Than: Date	Arrive No Later Than: Time
Stopover 5	
Arrive No Later Than: Date	Arrive No Later Than: Time
Stopover 6	
Arrive No Later Than: Date	Arrive No Later Than: Time
Final Destination Port (If Different Than Home Port)	
Arrive No Later Than: Date	Arrive No Later Than: Time

If not returned by the date and time listed above, call the Coast Guard or other local authority.

Coast Guard Phone Number
Local Authority Phone Number

Part Number 1756981

Bayliner • P.O. Box 9029 • Everett, WA 98206 • 360-435-5571