

BAYLINER[®]

160, 180, & 184

Owner's Manual *Supplement*

Engine Serial Number: _____

Hull Identification Number: _____

Hull Identification Number

- The Hull Identification Number (HIN) is located on the starboard side of the transom.
- Record the HIN (and the engine serial numbers) in the space provided above.
- Include the HIN with any correspondence or orders.

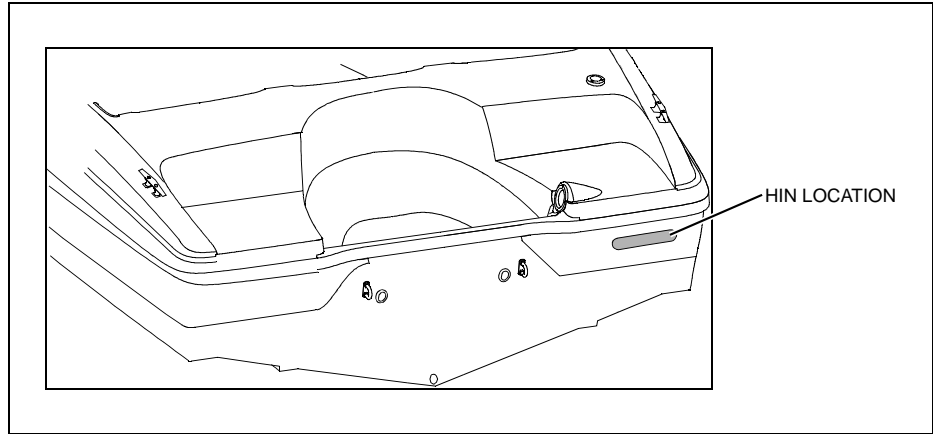

© 2004 Bayliner Technical Publications. All rights reserved.

No part of this publication may be reproduced, stored in any retrieval system, or transmitted in any form by any means, electronic, mechanical, photocopying, recording or otherwise, without prior written permission of Bayliner.
Printed in the United States of America.

General Notes

The material in this document is for information only and is subject to change without notice. While reasonable efforts have been made in the preparation of this document to assure its accuracy, Bayliner assumes no liability resulting from errors or omissions in this document, or from the use of information contained herein. Due to our commitment to product improvement, Bayliner reserves the right to make changes in the product design, specifications, and equipment at any time without notice or obligation. Illustrations and/or photos may show optional equipment. All Bayliner products meet or exceed USCG (United States Coast Guard) and/or NMMA (National Marine Manufacturer's Association) construction standards. Manufactured with 1,1,1 Trichloroethane, a substance which harms public health and environment during the manufacturing process by destroying ozone in the upper atmosphere.

Proprietary Rights

This document discloses subject matter in which Bayliner has proprietary rights. The information and design disclosed herein were originated by and are the property of Bayliner. Neither receipt nor possession thereof confers or transfers any right to reproduce, copy, alter or disclose the document or any part thereof, any information contained therein, or to construct boats or any item from it, except by written permission from or written agreement with Bayliner. This document is to be returned upon request to Bayliner.

CONTENTS

1 Chapter 1: Welcome Aboard!

- 1 Dealer Service
- 1 Warranty Information
- 1 Boating Experience
- 2 Engine & Accessories Guidelines
 - 2 *Propeller*
- 2 Engine & Accessories Literature
- 3 Qualified Maintenance
- 3 Special Care For Moored Boats
- 4 Safety Standards
- 5 Carbon Monoxide (CO)
 - 5 *Facts about CO*
 - 6 *Where and How CO Can Accumulate*
 - 6 *How to Protect Yourself and Others From CO*
 - 7 *CO Checklists*
 - 7 *More Information*

8 Chapter 2: Product Specifications

- 8 160
- 8 180
- 9 184

10 Chapter 3: Locations

- 10 Exterior Views
 - 10 *Hull Views*
 - 11 *160 Deck View*
 - 12 *180 Deck View*
 - 13 *184 Deck Views*
 - 14 *160 & 180 Helm View*
 - 14 *184 Helm View*
- 15 Component Locations

19 Chapter 4: Propulsion & Related Systems

- 19 Engine
- 19 Fuel System
 - 20 *Fuel Fill & Vent*
 - 20 *Fuel Filters*

21 Chapter 5: Controls & Gauges

- 21 Steering
- 21 Shift/Throttle Control
- 21 Power Trim and Tilt
- 22 Gauges
 - 22 *Cleaning Gauges*
 - 22 *Gauge Fogging*
 - 22 *Radio Transmission Interference*
 - 22 *Fuel Gauge*

23 Chapter 6: Plumbing

- 23 Bilge Pump
 - 23 *Bilge Pump Testing*
- 24 Drain Systems
 - 24 *Deck Drains*
- 24 Seawater System (184 Only)
 - 24 *Seacock*
- 25 Livewell System (184 Only)

26 Chapter 7: Deck Equipment

- 26 Cleats and Tow Eyes
- 26 Pre-rigging For Bow Mount Trolling Motor (184 Only)
- 27 Ski Pylon (If Equipped)
- 28 Canvas (If Equipped)
 - 28 *160 Bimini Top (If Equipped)*
 - 28 *160 Convertible Top (If Equipped)*
 - 29 *180 Bimini Top (If Equipped)*
 - 29 *180 Convertible Top (If Equipped)*
 - 30 *184 Bimini Top (If Equipped)*
 - 30 *184 Convertible Top (If Equipped)*
 - 31 *Canvas Care*
 - 32 *Clear Vinyl Care*

33 Chapter 8: Entertainment System

- 33 Audio System (If Equipped)

34 Chapter 9: Convertible Seats

- 34 Sleeper Seats (180 Only)
 - 34 *Operating Positions*
 - 34 *Lounge positions*
- 35 Removable Fishing Seat (184 Only)

36 Chapter 10: Lights

- 36 Care and Maintenance
- 36 Lights
- 36 Navigation Lights

37 Chapter 11: Electrical System

- 38 *Battery*
- 38 *Fuses and Circuit Breakers*
- 38 *12-Volt Accessory Outlet(s)*
- 38 *Alternator*
- 39 Electrical Routings
 - 39 *160 Deck Electrical Harnesses*
 - 40 *180 Deck Electrical Harnesses*
 - 41 *184 Deck Electrical Harnesses*
 - 42 *160 Hull Electrical Harness*
 - 42 *180 & 184 Hull Electrical Harness*
- 43 Wiring Diagrams
 - 43 *160 & 180 Engine Electrical System*
 - 44 *184 Engine Electrical System*
 - 45 *Trolling Motor Harness (184 Only)*

46 Important Records

47 Float Plan

Hazard Boxes & Symbols

The hazard boxes and symbols shown below are used throughout this supplement to call attention to potentially dangerous situations which could lead to either personal injury or product damage. **Read ALL warnings carefully and follow all safety instructions.**

 **DANGER!**
This box alerts you to immediate hazards which **WILL** cause severe personal injury or death if the warning is ignored.

 **WARNING!**
This box alerts you to hazards or unsafe practices which **COULD** result in severe personal injury or death if the warning is ignored.

 **CAUTION**
This box alerts you to hazards or unsafe practices which **COULD** result in minor personal injury or cause product or property damage if the warning is ignored.

NOTICE
This box calls attention to installation, operation or maintenance information, which is important to proper operation but is not hazard related.



Chapter 1: Welcome Aboard!

- This *Owner's Manual Supplement* provides information about your boat that is **not** covered in the *Sport Boat Owner's Manual*.
- **Before** using your boat, study this *Owner's Manual Supplement*, the *Sport Boat Owner's Manual*, and **all** engine and accessory literature carefully.
- Keep this *Owner's Manual Supplement* and the *Sport Boat Owner's Manual* on your boat in a secure, yet readily available place.

Dealer Service

- Your dealer is your key to service.
- Ask your dealer to explain **all** systems **before** taking delivery of your boat.
- Contact your dealer if you have any problems with your new boat.
- If your dealer cannot help, call our customer service hotline: 360-435-8957 or send us a FAX: 360-403-4235.
- Buy replacement parts from any authorized Bayliner dealer.

Warranty Information

- Bayliner offers a Limited Warranty on each new Bayliner purchased through an authorized Bayliner dealer.
- A copy of the Limited Warranty was included in your owner's packet.
- If you did not receive a copy of the Limited Warranty, please contact your Bayliner dealer or call 360-435-8957 for a copy.

Boating Experience

 **WARNING!**

CONTROL HAZARD!

A qualified operator **must** be in control of the boat at **all** times. **DO NOT** operate your boat while under the influence of alcohol or drugs.

If this is your first boat or if you are changing to a type of boat you are **not** familiar with, for your own comfort and safety, obtain handling and operating experience **before** assuming command of this boat.

Take one of the boating safety classes offered by the U.S. Power Squadrons or the U.S. Coast Guard Auxiliary. For more course information, including dates and locations of upcoming classes, contact the organizations directly:

- U.S. Power Squadrons: 1-888-FOR-USPS (1-888-367-8777) or on the Internet at: <http://www.usps.org>
- In Canada, for the CPS courses call 1-888-CPS-BOAT.
- U.S. Coast Guard Auxiliary: 1-800-368-5647 or on the Internet at: <http://www.cgaux.org>

Outside the United States, your selling dealer, national sailing federation or local boat club can advise you of local sea schools or competent instructors.

Engine & Accessories Guidelines

NOTICE

When storing your boat please refer to your engine's operation and maintenance manuals.

- Your boat's engine and accessories were selected to provide optimum performance and service.
- Installing a different engine or other accessories may cause unwanted handling characteristics.
- Should you choose to install a different engine or to add accessories that will affect the boat's running trim, have an experienced marine technician perform a safety inspection and handling test *before* operating your boat again.

Certain modifications to your boat *will* result in cancellation of your warranty protection.

- *Always* check with your dealer *before* making any modifications to your boat.

Propeller



CAUTION

ENGINE DAMAGE HAZARD!

The factory standard propeller may not be the best for your particular boat and load conditions. Refer to the engine manual for engine RPM ratings. The engine should reach, but not exceed its full rated RPM when full-throttle is applied.

Immediately contact your local Bayliner dealer if:

- The engine cannot reach its full rated RPM when full-throttle is applied, or;
- The engine exceeds its full rated RPM when full-throttle is applied.

- Keep the propeller in good repair and at the correct pitch for your particular situation.
- A slightly bent or nicked propeller *will* adversely affect the performance of your boat.

Engine & Accessories Literature

- The engine and accessories installed on your boat come with their own operation and maintenance manuals.
- Read these manuals *before* using the engine and accessories.
- Unless noted otherwise, *all* engine and accessory literature referred to in this *Supplement* is included in your owner's packet.

Qualified Maintenance

 WARNING!
<p>To maintain the integrity and safety of your boat, allow <i>only</i> qualified personnel to perform maintenance on, or in any way modify the:</p> <ul style="list-style-type: none">• Steering System• Propulsion System• Engine Control System• Fuel System• Environmental Control System• Electrical System• Navigational System

- Failure to maintain your boat's systems (listed in the warning above) as designed could violate the laws in your jurisdiction and could expose you and other people to the danger of bodily injury or accidental death.
- Follow the instructions provided in the *Sport Boat Owner's Manual*, this *Supplement*, the engine owner's manual and *all* accessory literature.



Special Care For Moored Boats

NOTICE
<ul style="list-style-type: none">• To help seal the hull bottom and reduce the possibility of gelcoat blistering on moored boats, apply an epoxy barrier coating.• The barrier coating should be covered with several coats of anti-fouling paint.• Many states regulate the chemical content of bottom paints in order to meet environmental standards. Check with your local dealer about recommended bottom paints, and about the laws in effect in your area.

- Whether moored in saltwater or freshwater, your boat will collect marine growth on its hull bottom.
- This will detract from the boat's beauty, greatly affect its performance and may damage the gelcoat.
- Periodically haul the boat out of the water and scrub the hull bottom with a bristle brush and a solution of soap and water.

Safety Standards

⚠ DANGER!	
	<p><i>FALLING and ROTATING PROPELLER HAZARD!</i></p> <ul style="list-style-type: none"> • NEVER allow anyone to ride on parts of the boat <i>not</i> designed for such use. • Sitting on seat backs, lounging on the forward deck, bow riding, gunwale riding or occupying the transom platform while underway is especially hazardous and <i>will</i> cause personal injury or death.

⚠ DANGER!	
 	<p><i>ROTATING PROPELLER and CARBON MONOXIDE POISONING HAZARD!</i></p> <ul style="list-style-type: none"> • NEVER allow anyone to occupy, or hang from, the back deck or swim platform while the engine(s) are running. • Teak surfing, dragging, or water skiing within 20 feet of a moving watercraft can be fatal.

⚠ DANGER!	
<p><i>PERSONAL SAFETY HAZARD!</i></p> <p><i>ALWAYS</i> secure the anchor and other loose objects <i>before</i> getting underway. The anchor and other items that are <i>not</i> properly secured can come loose when the boat is moving and cause personal injury or death.</p>	

- Your boat's mechanical and electrical systems were designed to meet safety standards in effect at the time it was built.
- Some of these standards were mandated by law, all of them were designed to insure your safety, and the safety of other people, vessels and property.

In addition to this *Supplement*, please read the *Sport Boat Owner's Manual* and **all** accessory instructions for important safety standards and hazard information.

Carbon Monoxide (CO)

⚠ **DANGER!**



- Carbon monoxide gas (CO) is colorless, odorless, tasteless, and extremely dangerous.
- *All* engines, generators, and fuel burning appliances produce CO as exhaust.
- Prolonged exposure to low concentrations or very quick exposure to high concentrations *will* cause *BRAIN DAMAGE* or *DEATH*.
- Teak surfing, dragging, or water skiing within 20 feet of a moving watercraft can be fatal.

Facts about CO

- CO poisoning causes a significant number of boating deaths each year.
- Called the "silent killer", CO is an extremely toxic, colorless, odorless and tasteless gas.
- CO can harm or even kill you inside or outside your boat.
- CO can affect you whether you're underway, moored, or anchored.
- CO symptoms are similar to seasickness or alcohol intoxication.
- CO can make you sick in seconds. In high enough concentrations, even a few breaths can be fatal.
- Breathing CO blocks the ability of your blood to carry oxygen.
- The effects are cumulative, even low levels of exposure can result in injury or death.

Factors That Increase the Effects of CO Poisoning

- Age
- Smokers or people exposed to high concentrations of cigarette smoke
- Consumption of alcohol
- Lung disorders
- Heart problems
- Pregnancy

Where and How CO Can Accumulate

Stationary Conditions That Increase CO Accumulations Include:

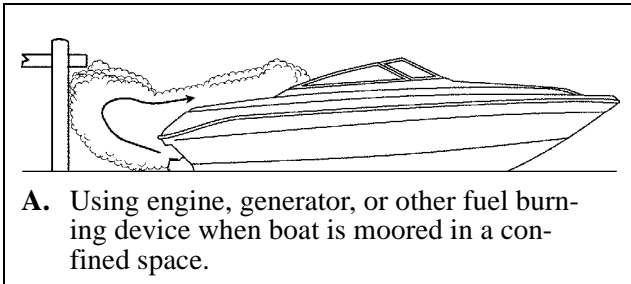

A. Using engine, generator, or other fuel burning device when boat is moored in a confined space.

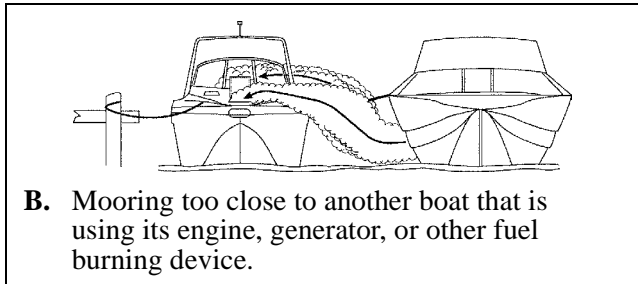

B. Mooring too close to another boat that is using its engine, generator, or other fuel burning device.

To correct stationary situations A and/or B:

- **Close all** windows, portlights and hatches.
- If possible, move your boat away from source of CO.

Running Conditions That Increase CO Accumulations Include:

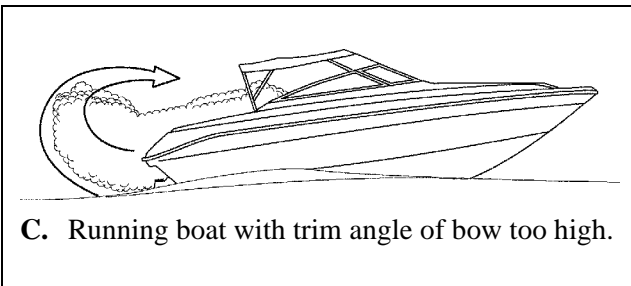

C. Running boat with trim angle of bow too high.

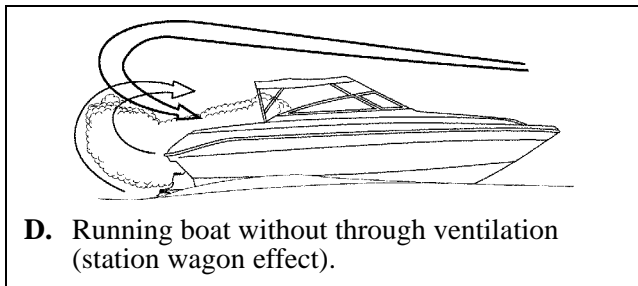

D. Running boat without through ventilation (station wagon effect).

To correct running situations C and/or D:

- Trim bow down.
- **Open** windows and canvas.
- When possible, run boat so that prevailing winds help dissipate exhaust.

How to Protect Yourself and Others From CO

- Know where and how CO may accumulate in and around your boat (see above).
- Maintain fresh air circulation throughout the boat at **all** times.
- Know where your engine and generator exhaust outlets are located and keep everyone away from these areas.
- **Never** sit on, or hang onto, the back deck or swim platform while the engine(s) are running.
- **Never** enter the areas under swim platforms where exhaust outlets are located.
- Although CO can be present without the smell of exhaust fumes, if exhaust fumes are detected on the boat, take **immediate** action to dissipate these fumes.
- Treat symptoms of seasickness as possible CO poisoning. Get the person into fresh air **immediately**. Seek medical attention—unless you're sure it's not CO.
- Install and maintain CO alarms inside your boat. Do **not** ignore any alarm. Replace alarms as recommended by the alarm manufacturer.
- Follow the checklists provided on the next page.
- Get a Vessel Safety Check.

For information on how to get a free VESSEL SAFETY CHECK, visit www.vesselsafetycheck.org or contact your local U.S. Coast Guard Auxiliary or United States Power Squadrons®.

- U.S. Coast Guard Auxiliary: 1-800-368-5647 or on the Internet at: <http://www.cgaux.org>
- U.S. Power Squadrons: 1-888-FOR-USPS (1-888-367-8777) or on the Internet at: <http://www.usps.org>

CO Checklists

Trip Checklist

- Make sure you know where the exhaust outlets are located on your boat.
- Educate *all* passengers about the symptoms of CO poisoning and where CO may accumulate.
- When docked, or rafted with another boat, be aware of exhaust emissions from the other boat.
- Listen for any change in exhaust sound, which could indicate an exhaust component failure.
- Test the operation of each CO alarm by pressing the test button.

Monthly Checklist

- Make sure *all* exhaust clamps are in place and secure.
- Look for exhaust leaking from exhaust system components. Signs include rust and/or black streaking, water leaks, or corroded or cracked fittings.
- Inspect rubber exhaust hoses for burned, cracked, or deteriorated sections. *All* rubber hoses should be pliable and free of kinks.

Annual Checklist

Have a Qualified Marine Technician:

- Replace exhaust hoses if cracking, charring, or deterioration is found.
- Ensure that your engines and generators are properly tuned, and well maintained.
- Inspect each water pump impeller and the water pump housing. Replace if worn. Make sure cooling systems are in working condition.
- Inspect *all* metallic exhaust components for cracking, rusting, leaking, or loosening. Make sure they check the cylinder head gasket, exhaust manifold, water injection elbow, and the threaded adapter nipple between the manifold and the elbow.
- Clean, inspect, and confirm proper operation of the generator cooling water anti-siphon valve (if equipped).

More Information

For more information about how you can prevent carbon monoxide poisoning on recreational boats and other ways to boat more safely, contact:

United States Coast Guard Office of Boating Safety (G-OPB-3) 2100 Second Street SW Washington, DC 20593 www.uscgboating.org 1-800-368-5647	National Marine Manufacturers Association (NMMA) 200 East Randolph Drive Suite 5100 Chicago, IL 60601-9301 www.nmma.org 312-946-6200	American Boat & Yacht Council, Inc. (ABYC) 3069 Solomon's Island Road Edgewater, MD 21037-1416 www.abycinc.org 410-956-1050
---	--	--

For information on how to get a free VESSEL SAFETY CHECK, visit www.vesselsafetycheck.org or contact your local U.S. Coast Guard Auxiliary or United States Power Squadrons®.

- U.S. Coast Guard Auxiliary: 1-800-368-5647 or on the Internet at: <http://www.cgaux.org>
- U.S. Power Squadrons: 1-888-FOR-USPS (1-888-367-8777) or on the Internet at: <http://www.usps.org>

Chapter 2: Product Specifications

160

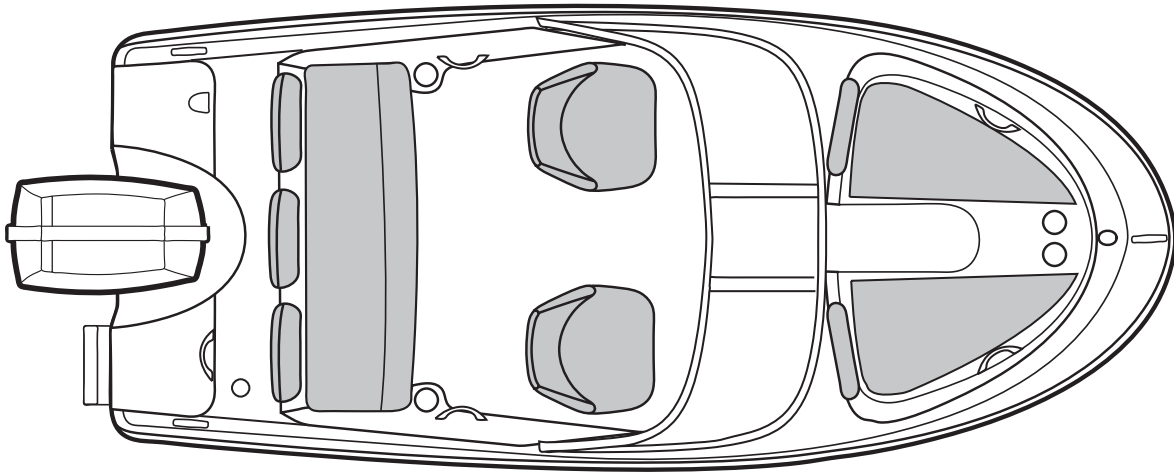

Overall Length	Bridge Clearance	Beam	Draft (Drive Up)	Draft (Drive Down)	Fuel Capacity
16' 2"	3' 5"	7' 2"	1' 2"	2' 7"	18 Gallons

180

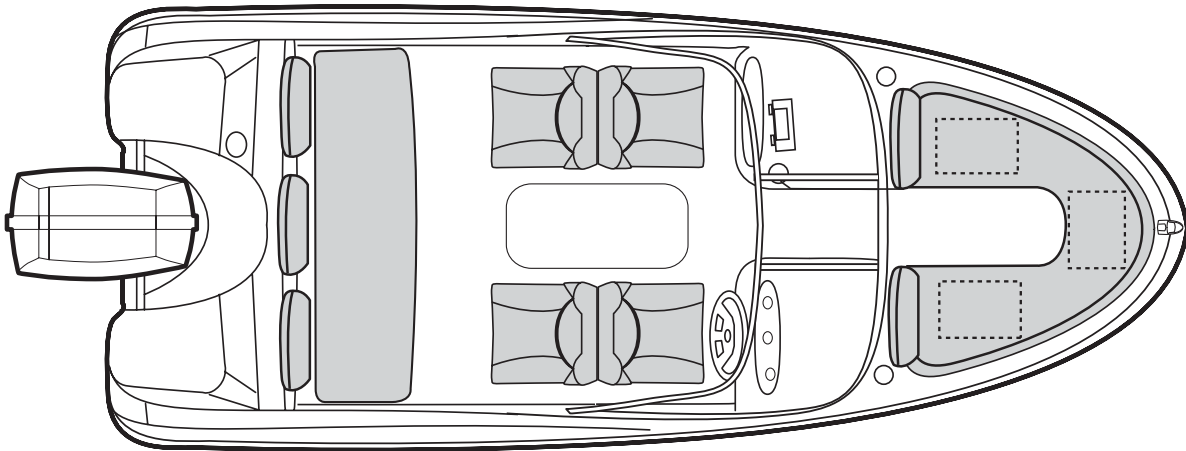

Overall Length	Bridge Clearance	Beam	Draft (Drive Up)	Draft (Drive Down)	Fuel Capacity
18' 0"	3' 10"	7' 6"	1' 2"	2' 7"	23 Gallons

184

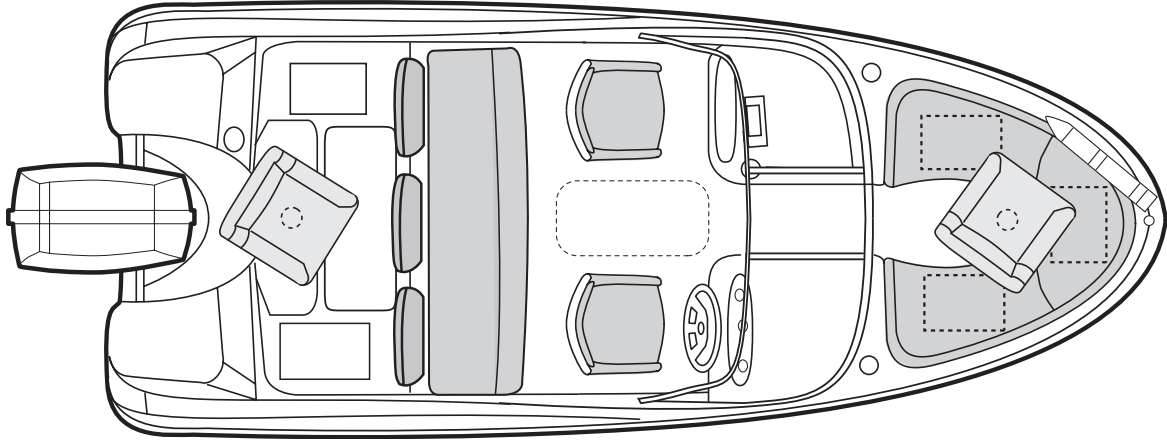

Overall Length	Bridge Clearance	Beam	Draft (Drive Up)	Draft (Drive Down)	Fuel Capacity
18' 0"	3' 10"	7' 6"	1' 2"	2' 7"	23 Gallons

Chapter 3: Locations

Exterior Views

Hull Views

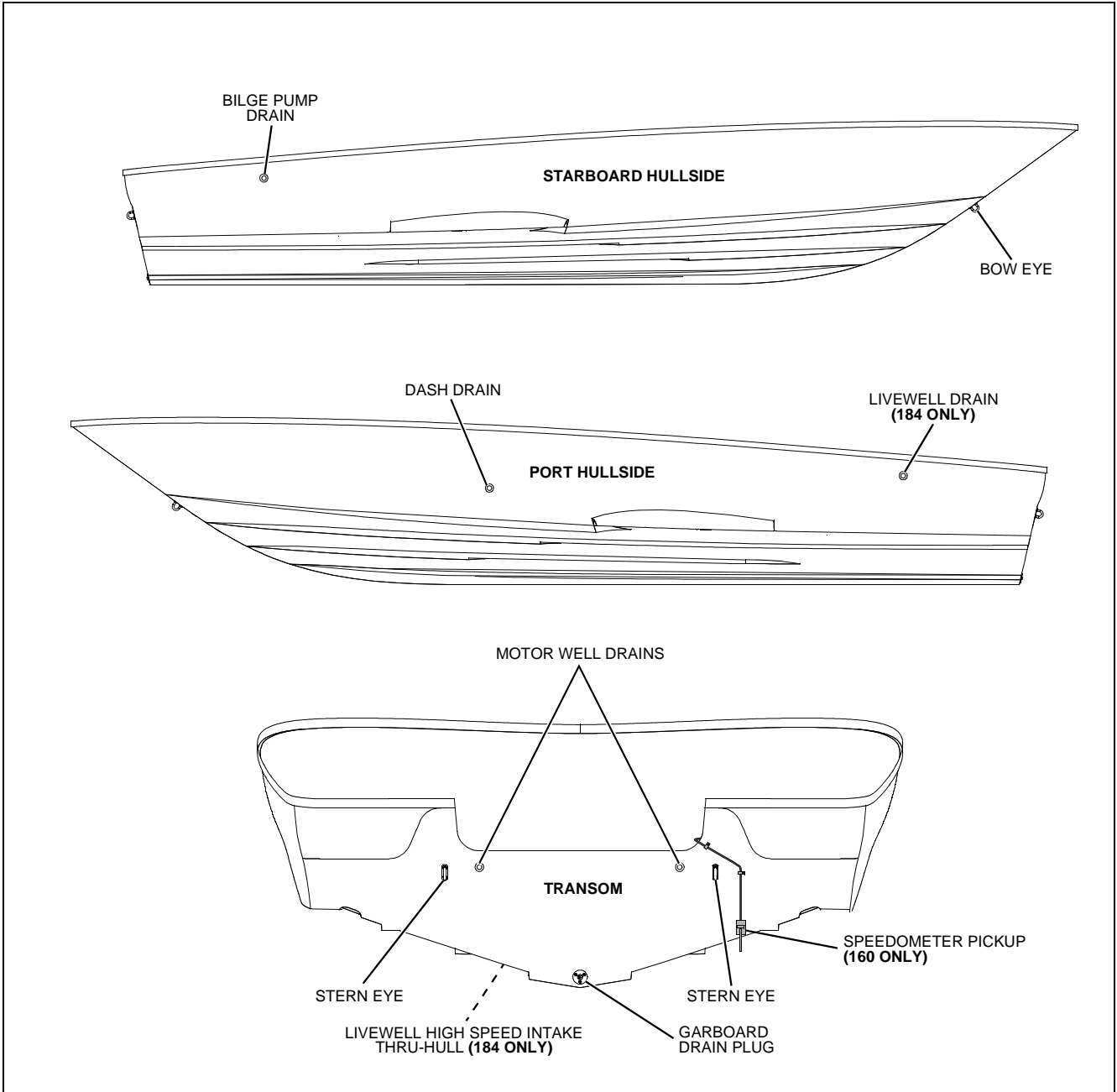

160 Deck View

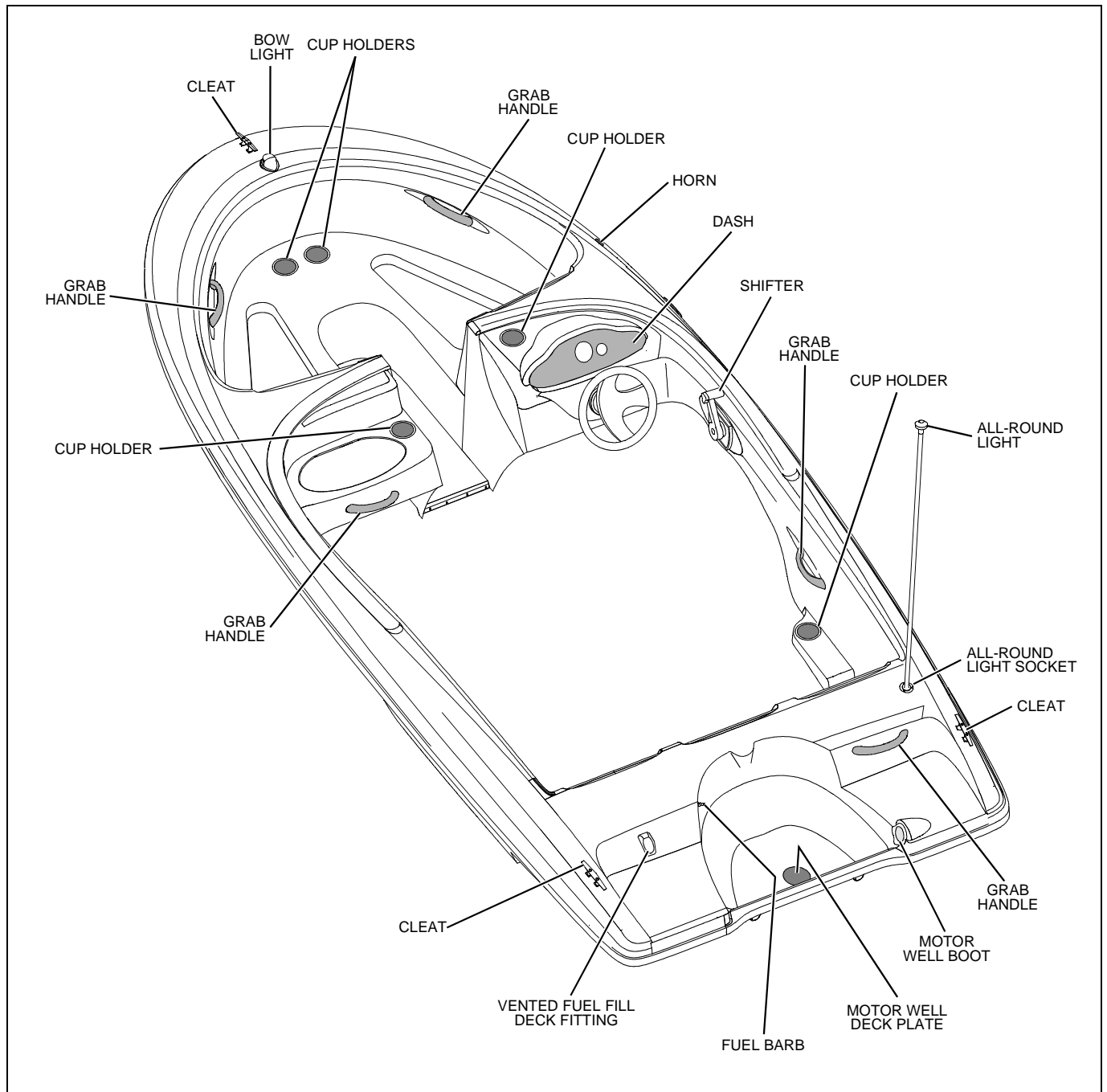

180 Deck View

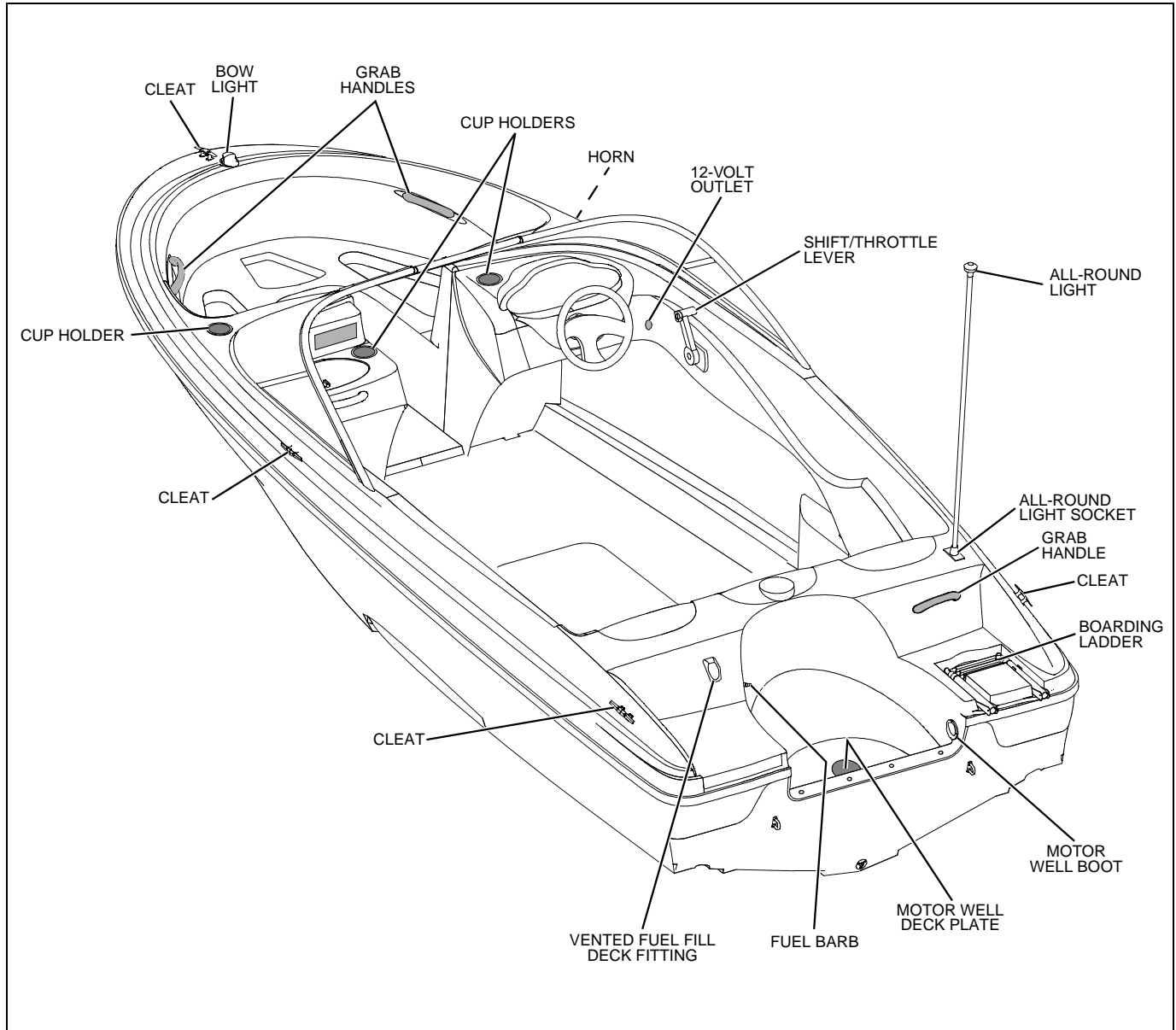

184 Deck Views

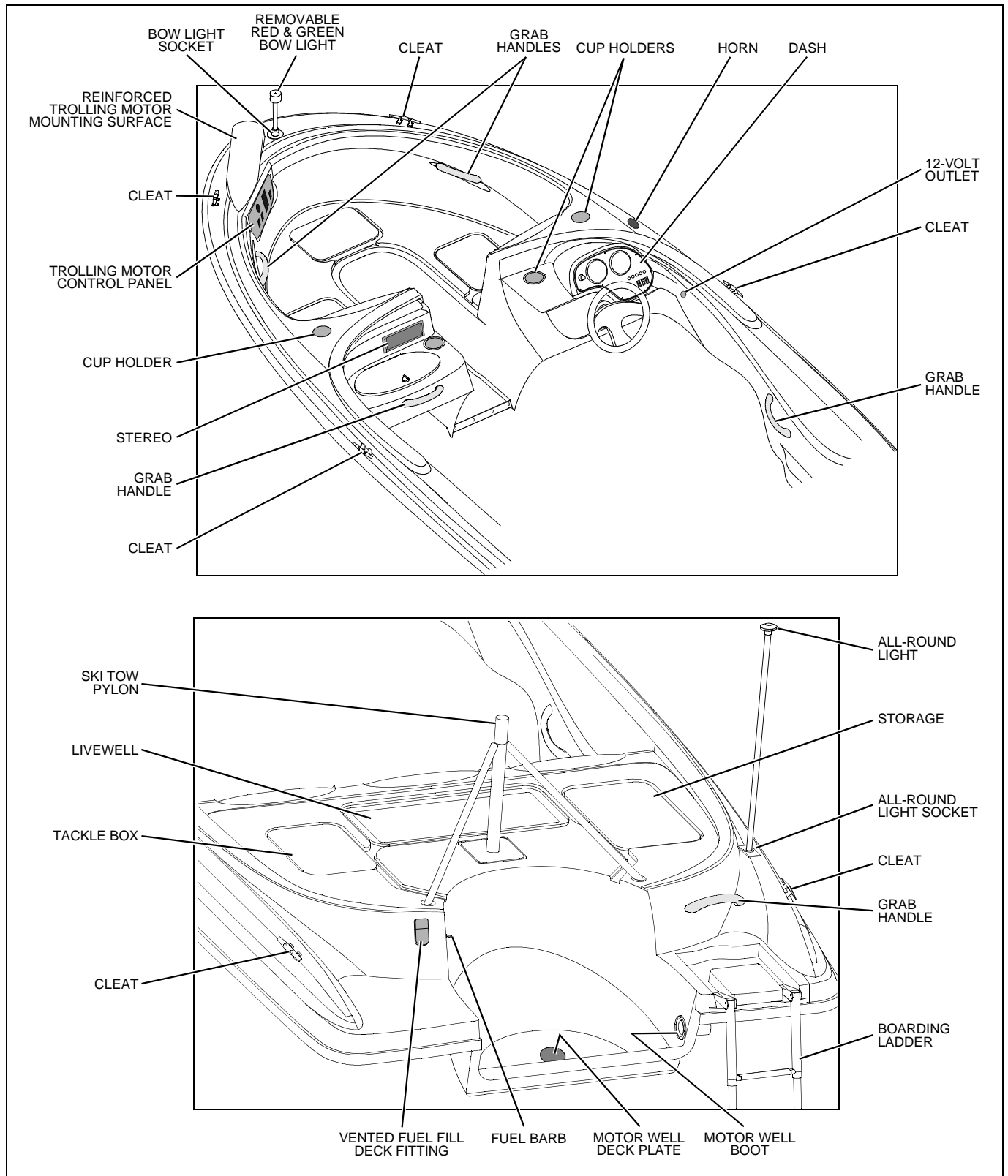

160 & 180 Helm View

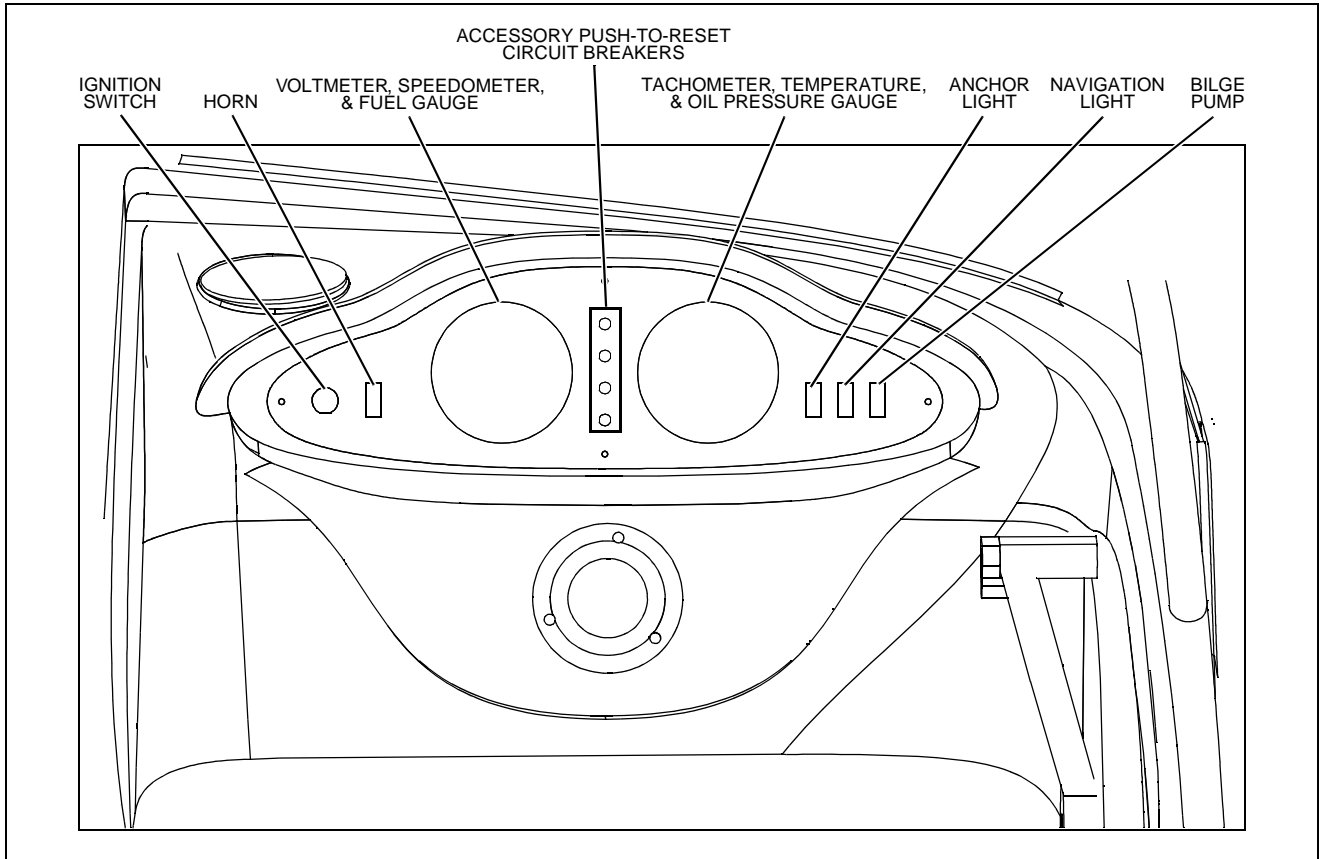

184 Helm View

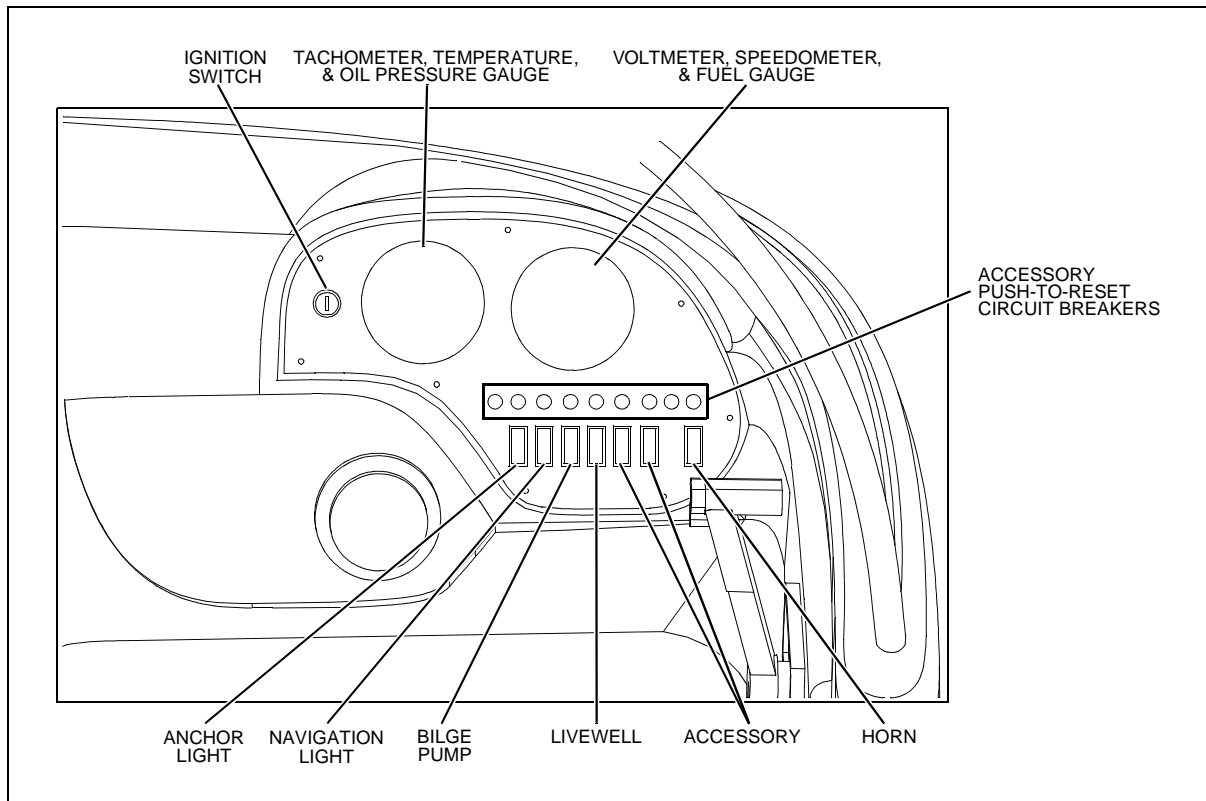

Component Locations

12-Volt Accessory Outlets - 180 & 184:

- One is located forward of the shift/throttle lever, next to the helm dash.
- One is located next to the MP3 jack and stereo on the port dash.

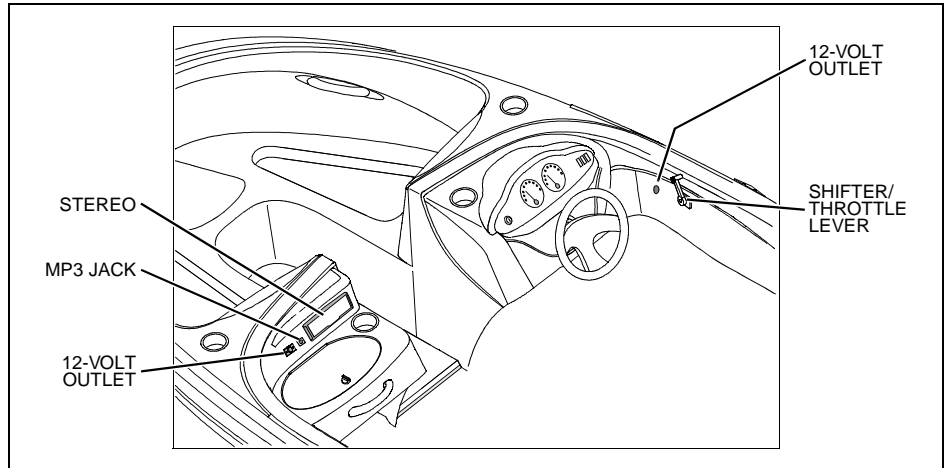

12-Volt Accessory Outlet - (184 Only):

- Located on the trolling motor control panel.

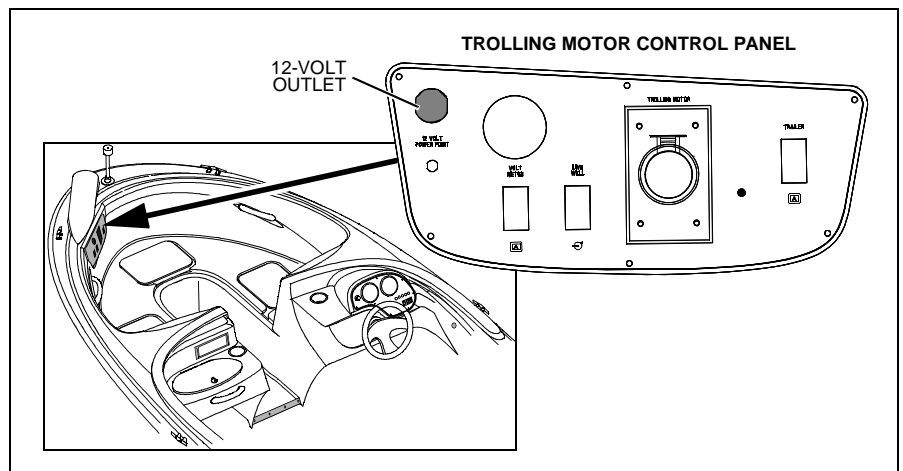

Accessory Push-To-Reset Circuit Breakers:

- Located at the helm.

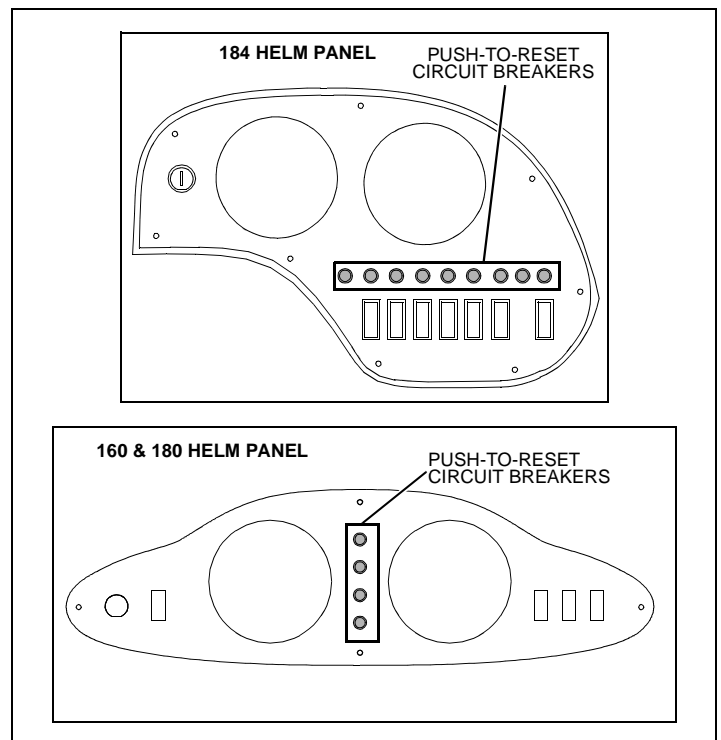

Battery:

- Located on the starboard side of the aft cockpit storage compartment.
- Access is through the opening along the bottom of the aft cockpit wall, under the aft cockpit bench seat.

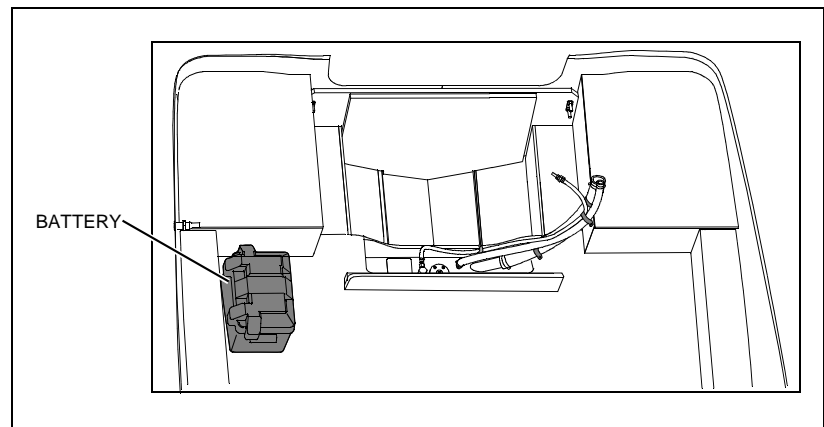
**Bilge Pump:**

- Located in the bilge under the motor well.
- Access is through the motor well deck plate.

Fuel Fill Deck Fitting:

- Located on the port aft corner of the deck.

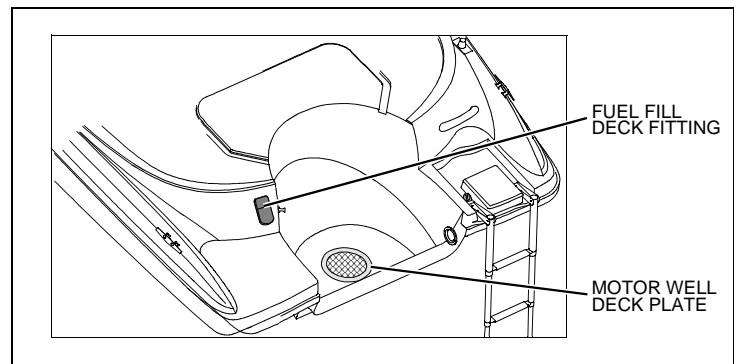
**Fuel Tank:**

- 160: Located on the port side of the aft cockpit storage compartment.
- 180 & 184: Located under the cockpit floor.
- Access is through the opening along the bottom of the aft cockpit wall, under the aft cockpit bench seat.

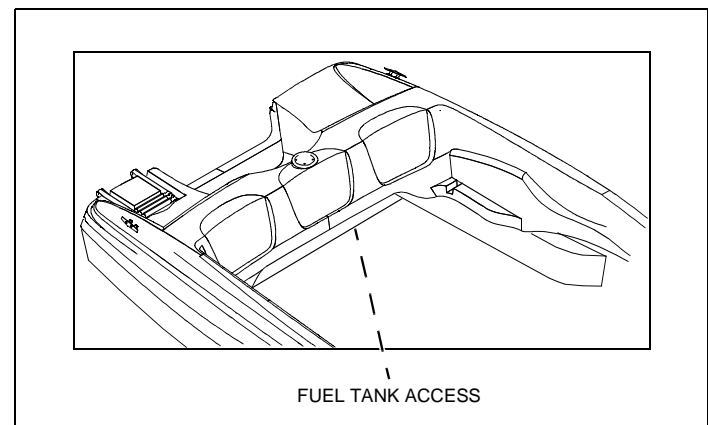
**Livewell Pump - (184 Only):**

- Located in the bilge under the motor well.
- Access is through the opening along the bottom of the aft cockpit wall.

Livewell Seacock - (184 Only):

- Located in the bilge under the motor well.
- Access is through the motor well deck plate

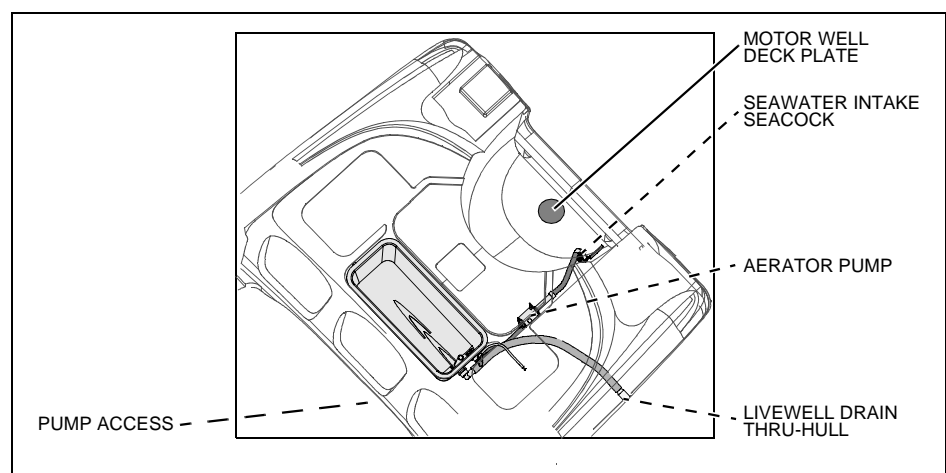

Livewell Switches - (184 Only):

- Located on the helm panel and the trolling motor control panel.

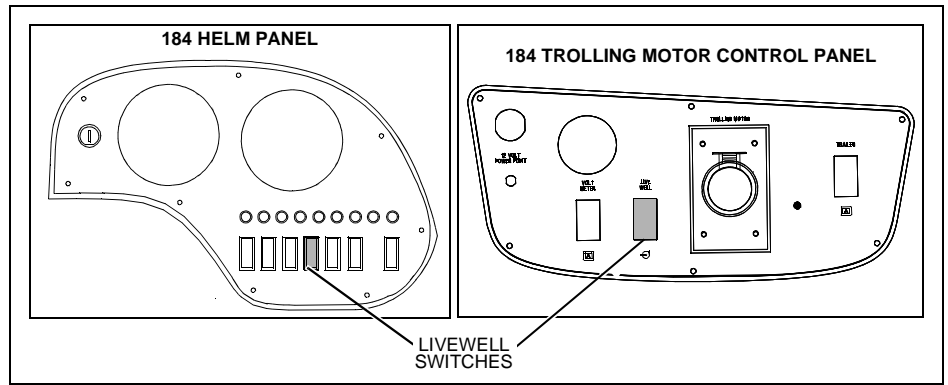

Navigation Lights - 160 & 180:

- The red and green light is located on the bow and a removable white all-round light is located on the stern.
- 160: The white all-round light is stored loose in the cockpit.
- 180: The white all-round light is stored on retaining clips under the aft cockpit bench.

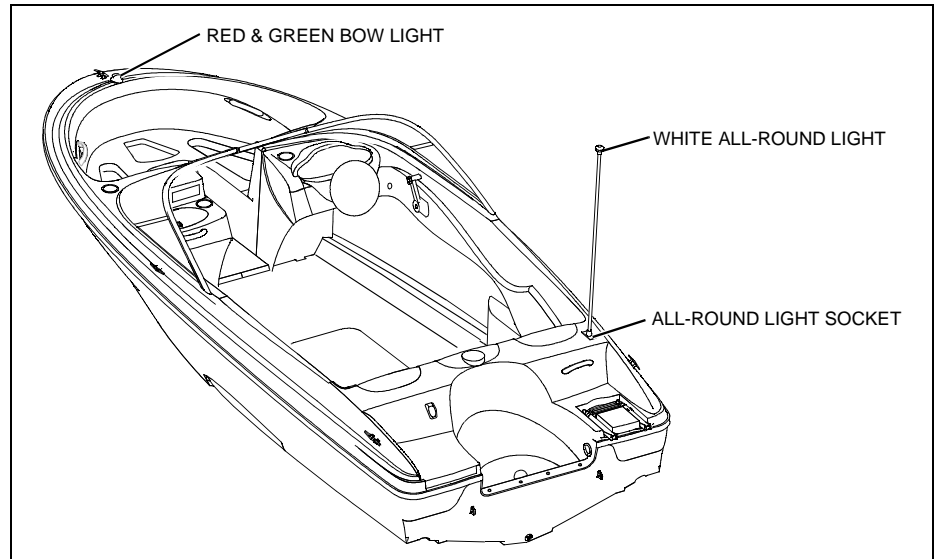

Navigation Lights - 184:

- A removable red and green bow light is located on the bow and a removable white all-round light is located on the stern.
- The bow light and the stern all-round light are stored on retaining clips under the aft cockpit bench.

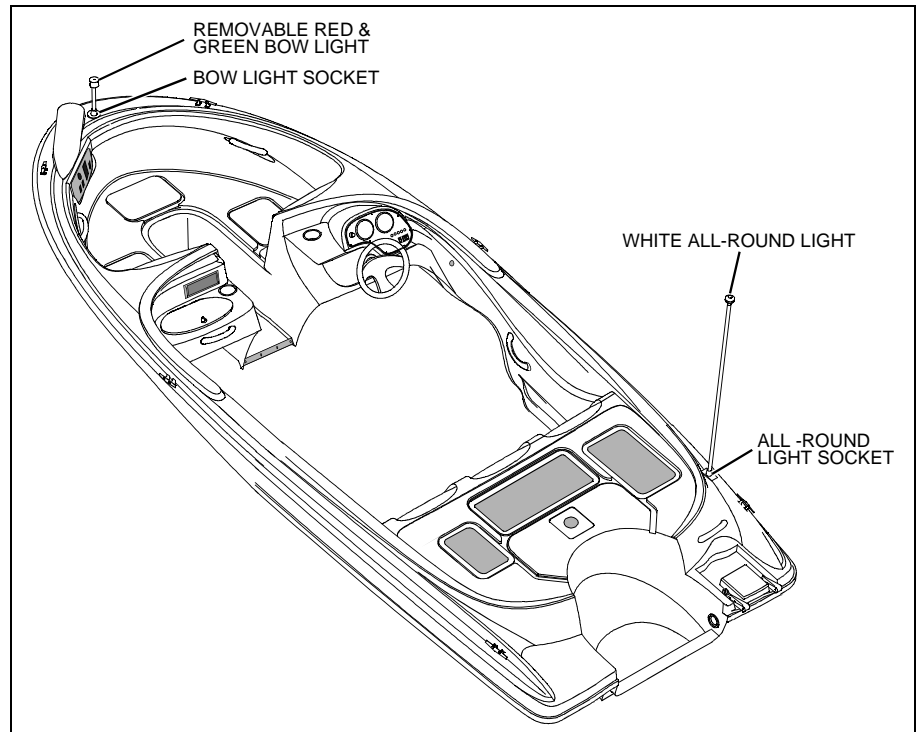

Trolling Motor Push-To-Reset Circuit Breakers (2) - (184 Only):

- Located on the port aft side of the cockpit, under the aft cockpit bench.

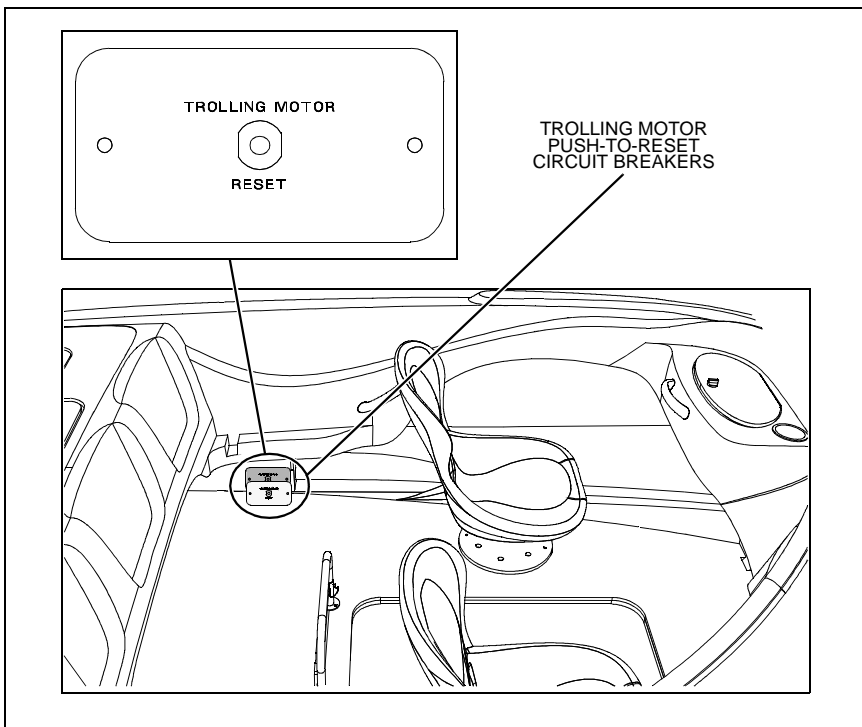





Chapter 4: Propulsion & Related Systems

Engine

Read the engine operation and maintenance manuals *before* starting or doing any maintenance on the engine.

Fuel System

 WARNING!	
  	FIRE, EXPLOSION AND OPEN FLAME HAZARD!
<ul style="list-style-type: none">• It is very important that the fuel system be inspected thoroughly the first time it is filled and at each subsequent filling.• The fueling instructions in the <i>Sport Boat Owner's Manual</i> and the fuel recommendations in the engine operation manual <i>must</i> be followed.	

 CAUTION	
Avoid the storage or handling of gear near the fuel lines, fittings and tank.	

NOTICE	
Carefully read the fuel section of both the <i>Sport Boat Owner's Manual</i> and the engine operation manual, paying special attention to the subject of <i>fuel recommendations</i> .	

Fuel Fill & Vent

- The fuel fill fitting is marked "Gas".
- If you have problems filling the fuel tank, see if the fuel fill hose or fuel tank vent hose is kinked or collapsed.
- If there are no visible signs of a problem, contact your local dealer.

Fuel Filters

- The fuel pickup tube, located inside the fuel tank, is equipped with a fine mesh screen filter.
- In addition, when supplied by the engine manufacturer, a fuel filter is installed on the engine.
- Periodically replace the fuel filters to make sure they remain clean and free of debris.
- Talk to your selling dealer or local marina about fuel additives that help prevent fungus or other buildup in your fuel tank.

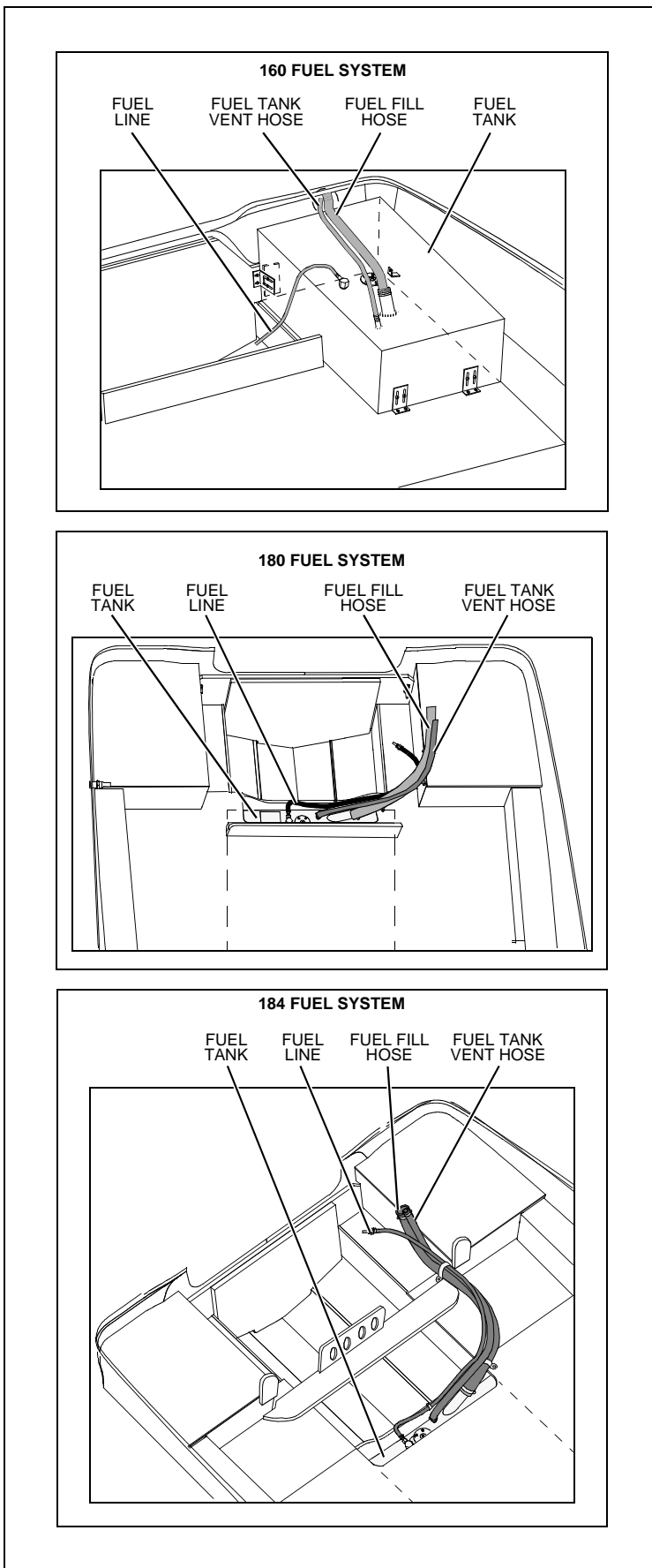

Chapter 5: Controls & Gauges

Steering

- This boat features a rack-and-pinion cable steering system.
- Boat steering is *not* self centering.
- Refer to the engine manual for more steering system details.

Shift/Throttle Control

 WARNING!
<i>LOSS OF CONTROL HAZARD!</i>
Improper maintenance of shift/throttle hardware may cause a sudden loss of control!

- Read *all* of the information about the shift/throttle control in the *Sport Boat Owner's Manual*.
- Also, read the shift/throttle control manual and the engine manual.

Power Trim and Tilt

- The outboard on your boat is equipped with power trim and tilt.
- Trim and tilt instructions are provided in the engine operation manual and the shifter/throttle manual.

Gauges

Cleaning Gauges

 CAUTION
<i>PRODUCT or PROPERTY DAMAGE HAZARD!</i>
<ul style="list-style-type: none">• Use only mild soap and water to clean the gauge lenses and bezels.• Use of other cleaners, including common window cleaning solutions, may cause the lenses to crack.• Lenses cracked in this manner will NOT be covered by our warranty.

Gauge Fogging

- Moisture may occasionally find its way into the gauges causing lens fogging.
- Turning *On* the gauge lights will help dry the lenses.
- Fogging will not harm the gauges.

Radio Transmission Interference

VHF or other radio transmissions may cause brief erratic readings on the tachometer. This will not damage the tachometer gauge or affect its accuracy when not transmitting.

Fuel Gauge

It is normal for the pointer on your fuel gauge to bounce as fuel sloshes back and forth in the fuel tank.

Chapter 6: Plumbing

Bilge Pump

NOTICE

Discharge of oil, oil waste or fuel into navigable waters is prohibited by law. Violators are subject to legal action by the local authorities.

- Your boat is equipped with a bilge pump for pumping water out of the bilge.
- The bilge pump is controlled by a switch at the helm.

Bilge Pump Testing

- The bilge pump is vital to the safety of your boat.
- Test the bilge pump often to make sure it is working properly.

To test each bilge pump:

- Turn *On* the bilge pump switch at the helm.
- If there is water in the bilge and a pump motor is running, but *not* pumping, inspect the discharge hose for a kink or collapsed area.

If the discharge hose looks okay, check the bilge pump housing for clogging debris.

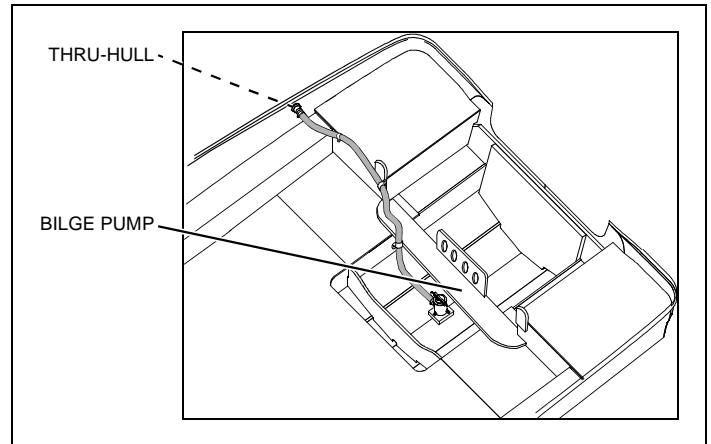

Checking for clogging debris:

1. Remove the pump motor from the housing:
 - a. Lift the tab while rotating the fins counter-clockwise.
 - b. Lift out the pump motor.
 - c. Clear the housing of debris.
2. Reinstall the pump motor:
 - a. Make sure the "O" ring is properly seated.
 - b. Coat the "O" ring with a light film of vegetable or mineral oil.
 - c. Align the cams on either side of the pump motor with the slots on the housing.
 - d. Press the pump motor into the housing while twisting clockwise.
3. Check the reinstallation by trying to twist the fins counter-clockwise *without* lifting the tab; the pump motor should stay in place.

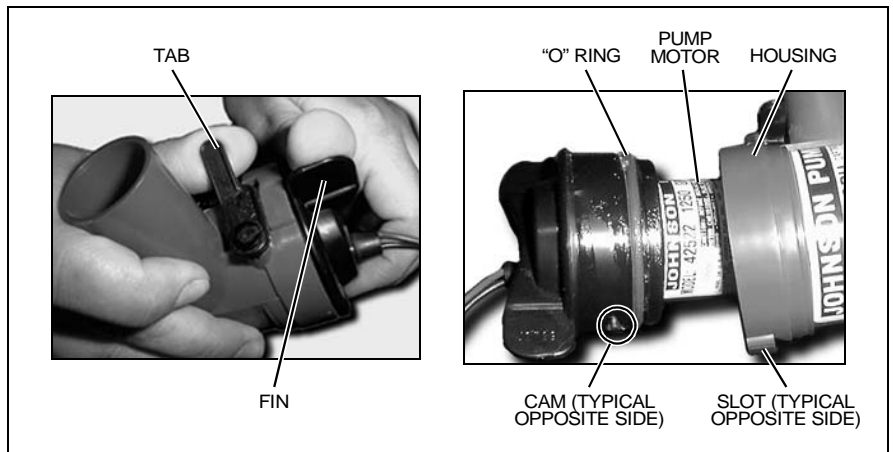

Drain Systems

Deck Drains

- Water on the deck is drained overboard through the deck drains.
- Keep the deck drains free of debris.

Seawater System (184 Only)

Seacock

CAUTION

SYSTEM DAMAGE HAZARD!

- *Before* using the seawater intake system, make sure that the system's seacock is in the *Open* position *before* the system is started and keep the seacock *Open* until the system is shut *Off*.
- *Close* the seacock whenever the system will *not* be used for long periods of time.

- A seacock is a thru-hull valve that may be opened to let in water.
- The seacock on the 184 is part of the livewell system.
- *Before* using the livewell, make sure that the seacock is *Open* and remains *Open* until the livewell is shut *Off*.

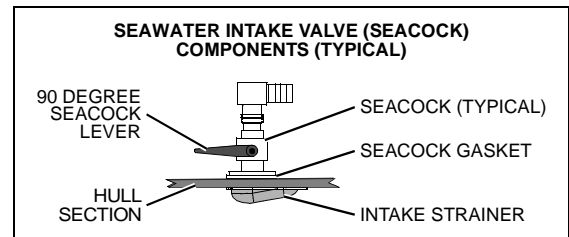

Livewell System (184 Only)



WARNING!

FLOODING & SWAMPING HAZARD!

- **NEVER** leave the boat unattended while the livewell system is running.
- Any leak or break in this system may allow large amounts of water to flood the bilge, which could swamp the battery(s), and even sink the boat.
- **ALWAYS Close** the intake seacock when you are done using the livewell system.



CAUTION

SYSTEM DAMAGE HAZARD!

Before turning On the livewell system, make sure that the intake seacock is in the Open position and keep the intake seacock Open until the system is shut Off.

Filling & Using the Livewell

1. Insert the end of the drain stand-pipe into the drain fitting at the bottom of the tank.
2. **Open** the seacock.
3. On the switch panel, turn **On** the livewell pump. See the Locations section of this *Supplement* for the location of the livewell pump switch.

The tank should now be filling with water. If water is **not** pumping into the tank, possible causes are:

- A collapsed hose or clogging debris in the system.
- The seawater intake seacock is **Closed**.
- The livewell fuse is blown.

To Drain the Livewell

Remove the stand-pipe to drain the livewell.

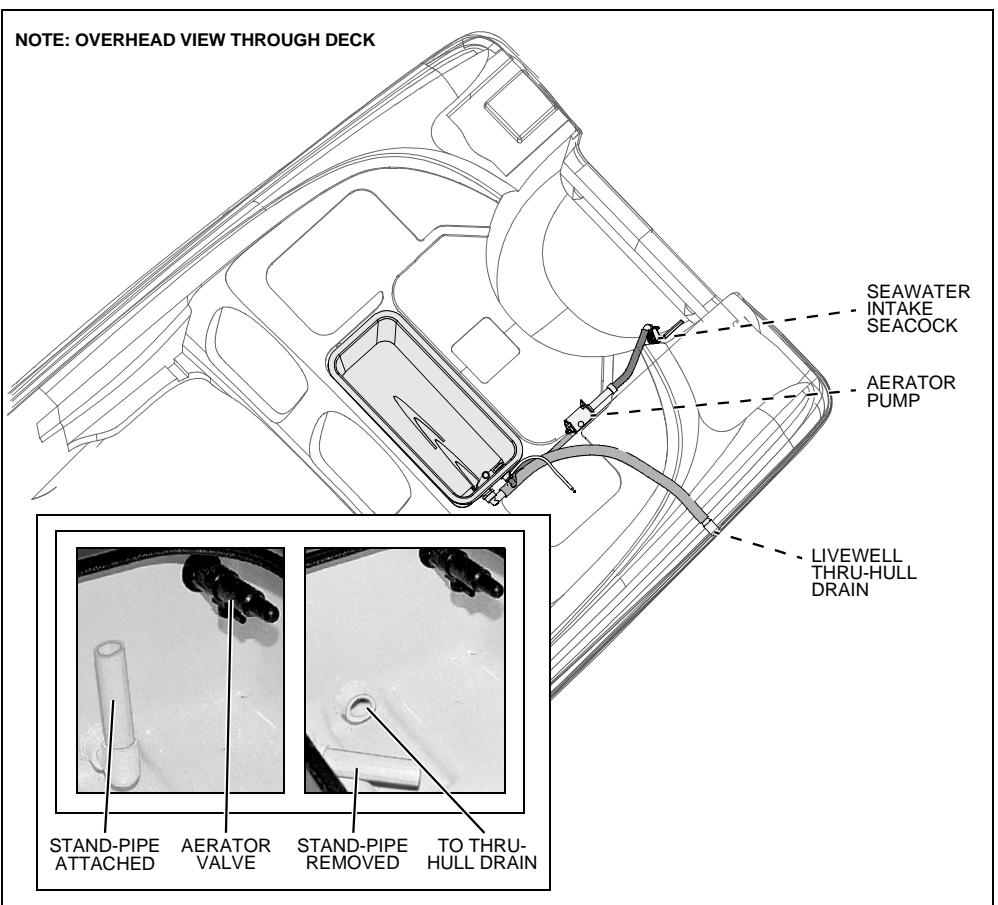

Chapter 7: Deck Equipment

Cleats and Tow Eyes

⚠ WARNING!

PERSONAL INJURY and/or PRODUCT or PROPERTY DAMAGE HAZARD!

NEVER lift the boat using the bow and stern eyes or the cleats.

Carefully read the section on towing in the *Sport Boat Owner's Manual* **before**:

- Towing anything behind the boat.
- Being towed by another vessel.

Pre-rigging For Bow Mount Trolling Motor (184 Only)

- The 184 features a trolling motor connection at the bow and a reinforced deck area designed to support a trolling motor mounting bracket.
- Contact your selling dealer for a list of compatible equipment and installation instructions.
- The trolling motor system can be used safely with either a 12-volt or a 24-volt motor.

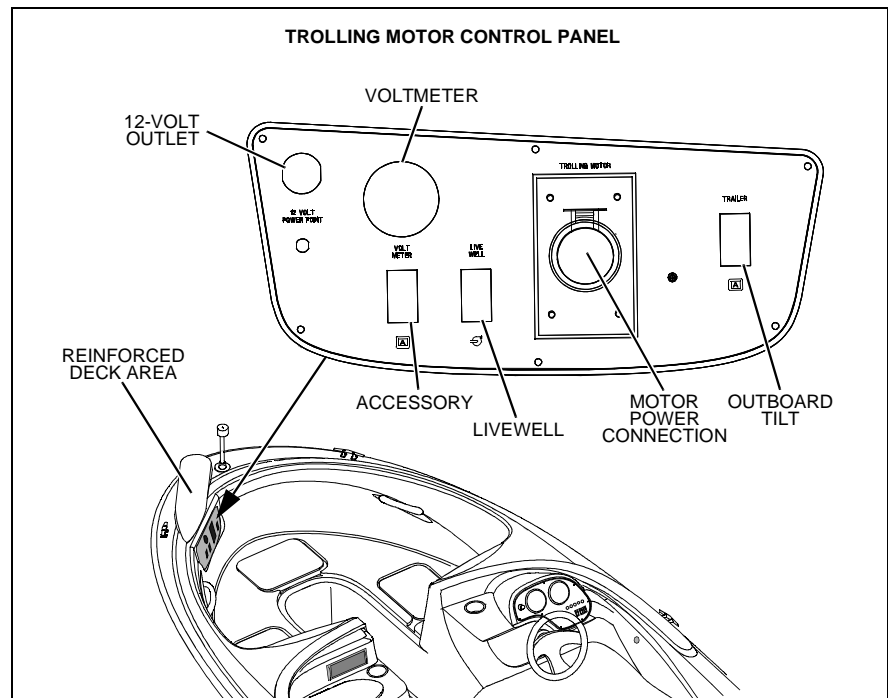

Ski Pylon (If Equipped)

⚠ WARNING!

When the ski pylon is in use, *all* passengers *must* sit forward of the ski pylon and keep their hands well clear of the pylon and rope. Failure to do so may result in *injury or death*.

Before using the ski pylon, read the "Waterski Safety Guidelines" pamphlet.

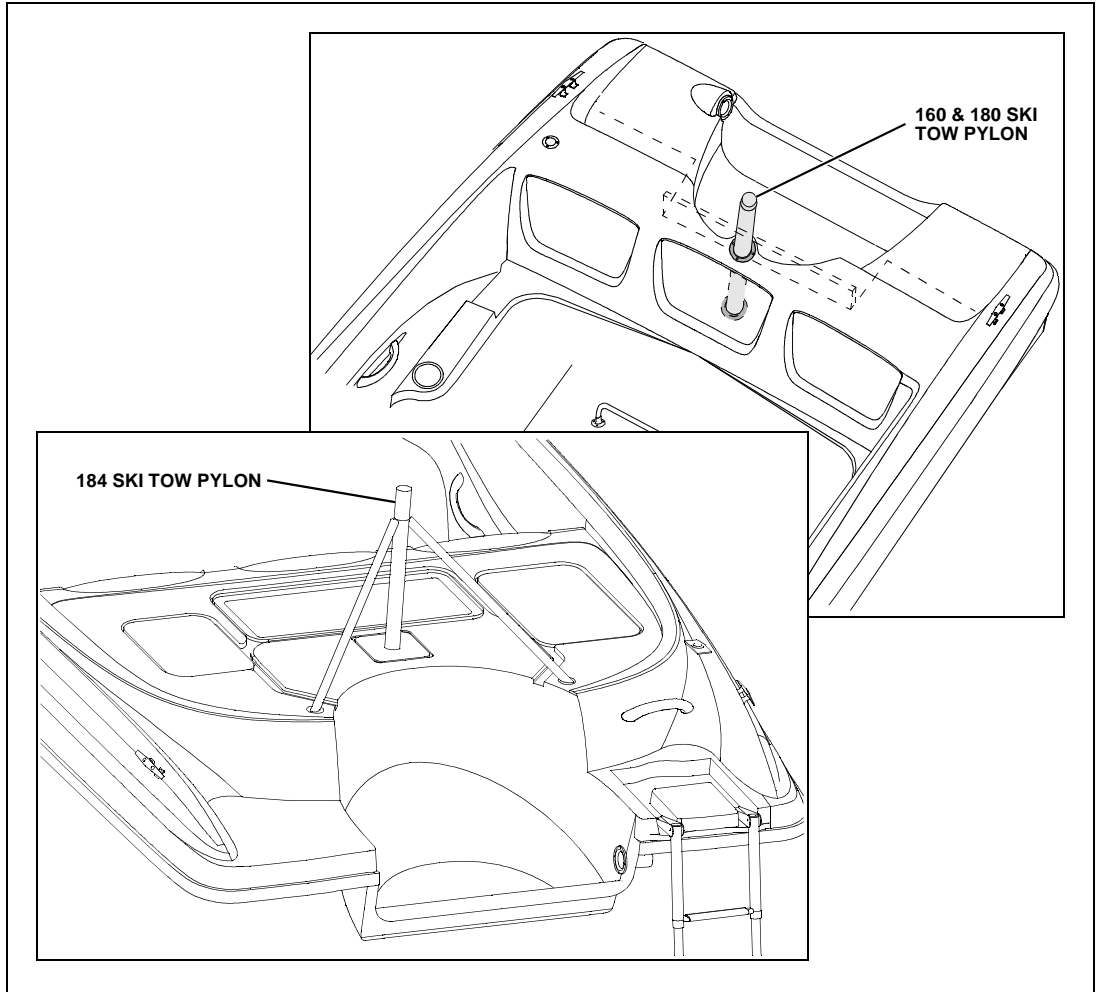

Canvas (If Equipped)



CAUTION

PRODUCT or PROPERTY DAMAGE HAZARD!

Take down and securely stow ALL canvas before transporting your boat by road.

160 Bimini Top (If Equipped)

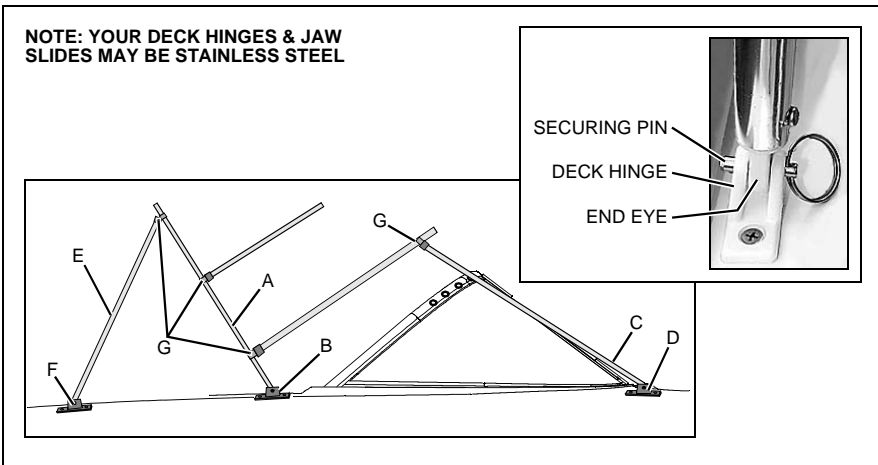
1. Insert the end eyes of the main bow (A) into the middle deck hinges (B) and insert the securing pins.
 2. Unfold the canvas and insert the end eyes of the forward braces (C) into the forward deck hinges (D) and insert the securing pins.
 3. Insert the end eyes of the aft braces (E) into the aft deck hinges (F) and insert the securing pins.
- The jaw slides (G) should not need to be adjusted.
 - If you decide to adjust the jaw slide positions, obtain the correct measurements from your selling dealer.



160 Convertible Top (If Equipped)

1. Insert the end eyes of the main bow (A) into the forward deck hinges (B) and insert the securing pins.
 2. Unfold the canvas top and snap the front edge of the top to the top of the windshield frame (C).
 3. Insert the end eyes of the aft braces (D) into the aft deck hinges (E) and insert the securing pins.
 4. Align the secondary bow (F) with the center seam (G) of the canvas by loosening or tightening the top straps (H).
- The jaw slides (I) should not need to be adjusted.
 - If you decide to adjust the jaw slide positions, obtain the correct measurements from your selling dealer.
 - If other canvas (i.e. side curtains or slant back cover) is installed, the canvas top may need adjustment to align the snaps on the canvas with the snaps on the boat.

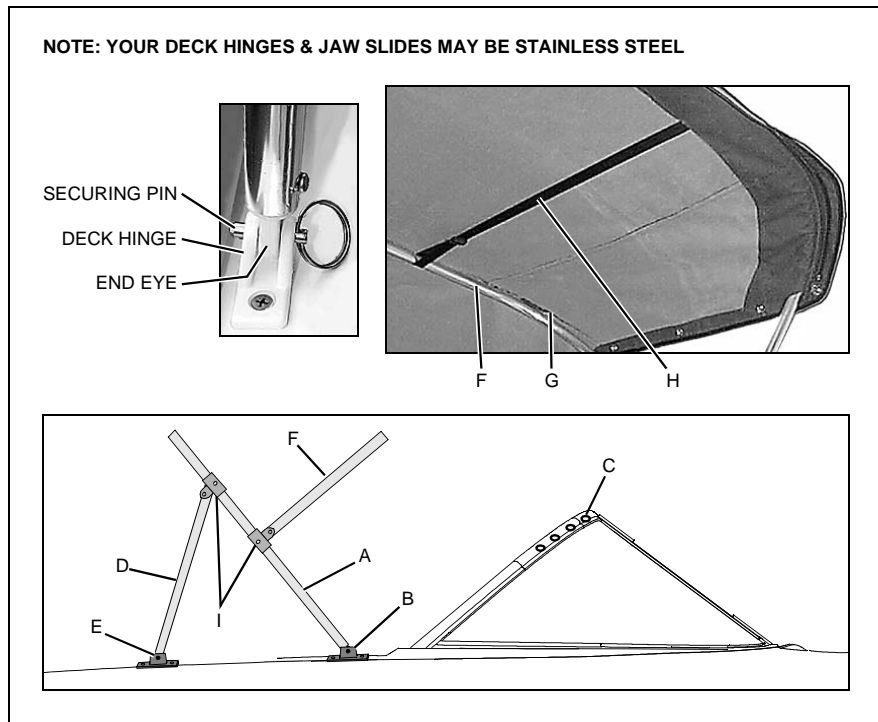

180 Bimini Top (If Equipped)

- Slide the windshield hinges of the main bow (A) over the aft pre-drilled holes (B) in the side windshield frames and insert the securing pins.
 - Unfold the canvas and slide the windshield hinges of the forward braces (C) over the forward pre-drilled holes (D) in the side windshield frames and insert the securing pins.
 - Insert the end eyes of the aft braces (E) into the deck hinges (F) and insert the securing pins.
- The jaw slides (G) should not need to be adjusted.
 - If you decide to adjust the jaw slide positions, obtain the correct measurements from your selling dealer.

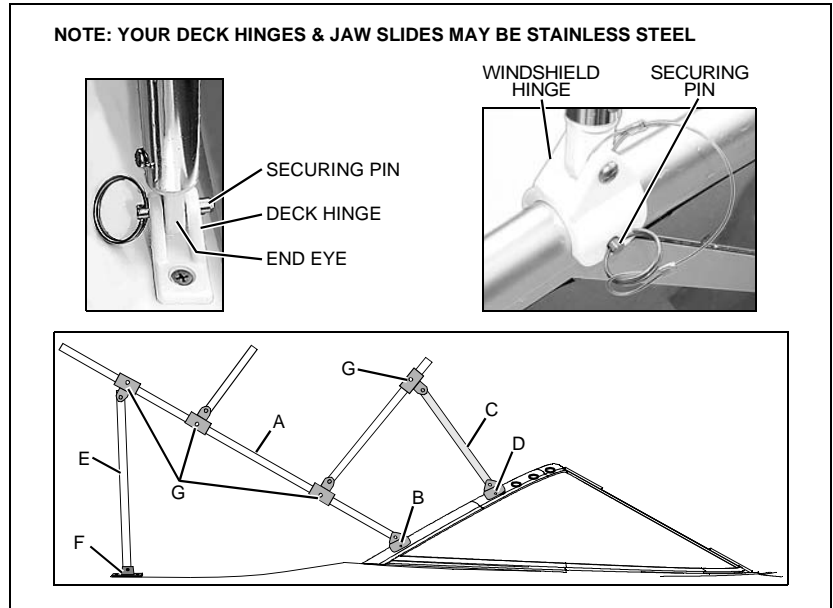

180 Convertible Top (If Equipped)

- Slide the windshield hinges of the main bow (A) over the pre-drilled holes (B) in the side windshield frames and insert the securing pins.
 - Unfold the canvas top and snap the front edge of the top to the windshield frame (C).
 - Close the front zipper (D).
 - Pull aft on the aft edge of the canvas top (E), making sure the canvas lies evenly from side to side and hook the hold down straps (F) to the deck loops (G).
 - Align the secondary bow (H) with the center seam (I) of the canvas by loosening or tightening the top straps (J).
 - If the canvas top does **not** have a smooth, taut look, tighten the hold down straps by pulling on the strap buckles (K).
- The jaw slides (L) should not need to be adjusted.
 - If you decide to adjust the jaw slide positions, obtain the correct measurements from your selling dealer.

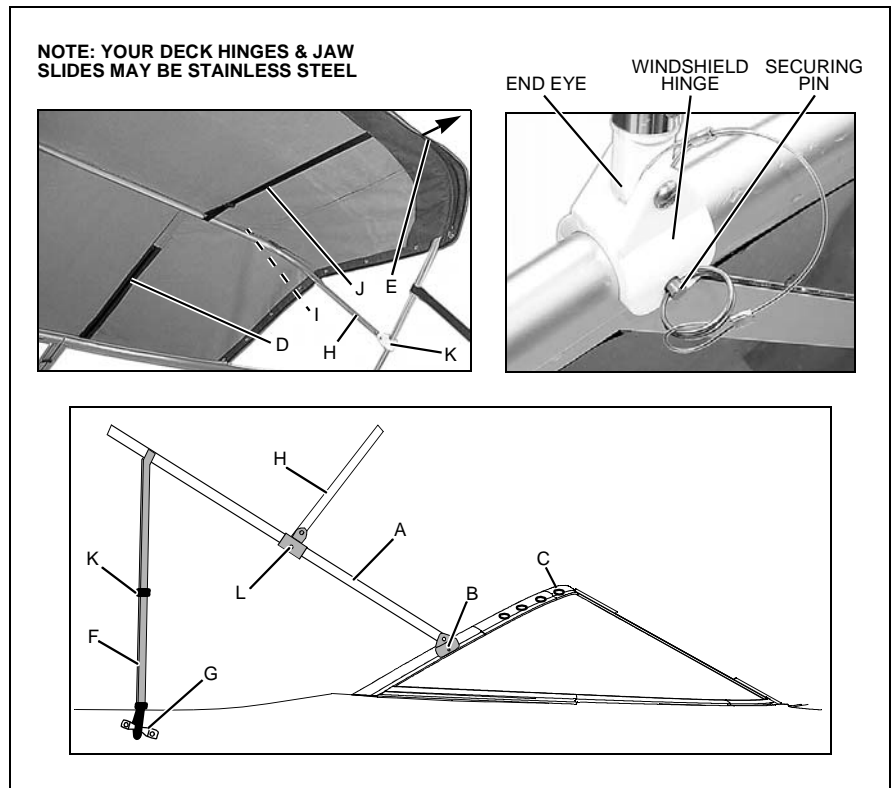

- If other canvas (i.e. side curtains or slant back cover) is installed, the canvas top may need adjustment to align the snaps on the canvas with the snaps on the boat.

184 Bimini Top (If Equipped)

1. Insert the end eyes of the main bow (A) into the middle deck hinges (B) and insert the securing pins.
 2. Unfold the canvas and insert the end eyes of the forward braces (C) into the forward deck hinges (D) and insert the securing pins.
 3. Insert the end eyes of the aft braces (E) into the aft deck hinges (F) and insert the securing pins.
- The jaw slides (G) should not need to be adjusted.
 - If you decide to adjust the jaw slide positions, obtain the correct measurements from your selling dealer.

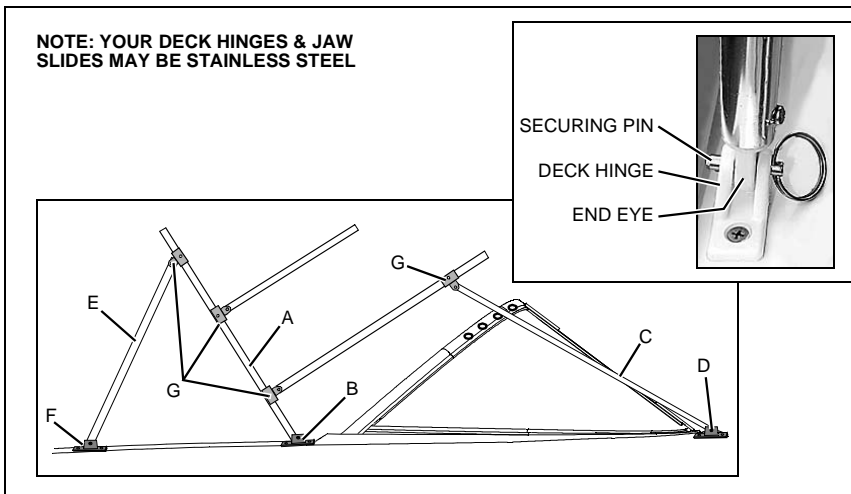

184 Convertible Top (If Equipped)

1. Insert the end eyes of the main bow (A) into the forward deck hinges (B) and insert the securing pins.
 2. Unfold the canvas top and snap the front edge of the top to the top of the windshield frame (C).
 3. Insert the end eyes of the aft braces (D) into the aft deck hinges (E) and insert the securing pins.
 4. Align the secondary bow (F) with the center seam (G) of the canvas by loosening or tightening the top straps (H).
- The jaw slides (I) should not need to be adjusted.
 - If you decide to adjust the jaw slide positions, obtain the correct measurements from your selling dealer.
 - If other canvas (i.e. side curtains or slant back cover) is installed, the canvas top may need adjustment to align the snaps on the canvas with the snaps on the boat.

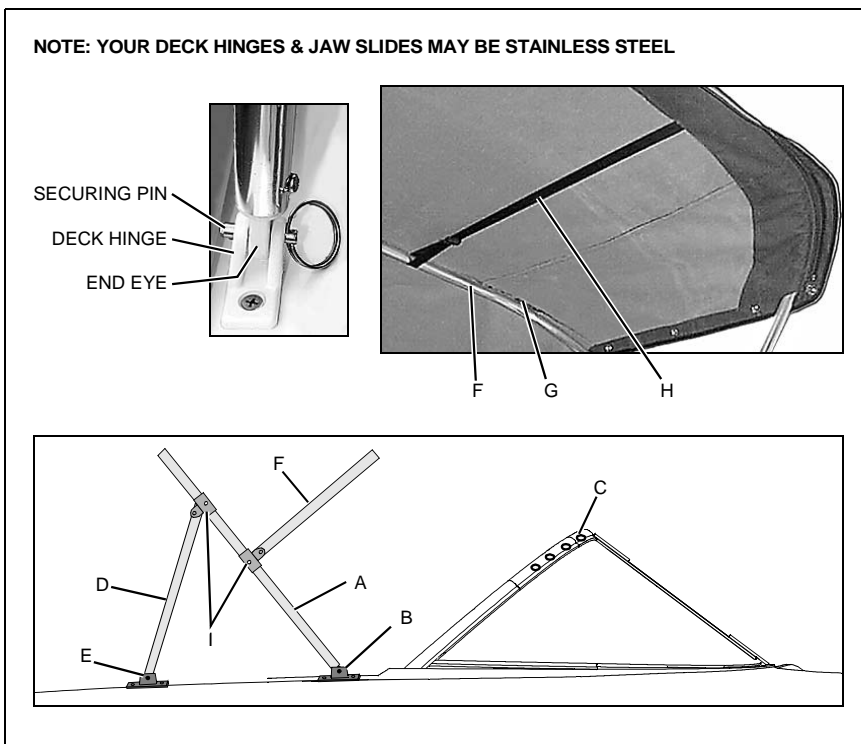

Canvas Care (see also, 'Clear Vinyl Care' on next page)

- After each use, especially in saltwater, rinse the canvas with cold freshwater.
- **Before** stowing, let the canvas air dry completely.
- The canvas can be rolled or folded for stowage.

Cleaning Canvas**CAUTION**

Never use detergents when washing the canvas. Detergents can destroy the water repellency, and mildew/UV resistant finish of your canvas.

Regularly clean the canvas to prevent dirt, pollen, and etc. from embedding in the fabric. Generally, it is easiest to wash the canvas while it is installed on the boat.

- Use a soft-bristled brush to remove all dust and loose dirt.
 1. Hose down the canvas with freshwater.
 2. Gently wash the canvas with a solution of lukewarm water (no more than 100 F) and non-detergent soap, such as Lux or Ivory Flakes.
 3. Rinse thoroughly to remove the soap.
 4. **Before** stowing, let the canvas dry completely.

Stubborn Stains**CAUTION**

- **Soaking in bleach solutions may remove the waterproof finish of the fabric and may also decrease the life of the polyester thread used in the canvas.**
- **If necessary, a water repellent treatment should be re-applied to your canvas. Ask your dealer about the treatments available for your boat's canvas.**

Some stubborn stains may resist normal washing and you can try the following methods. However, these methods may remove the waterproof finish of the fabric and may also decrease the life of the polyester thread used in the canvas. Reapply a water repellent treatment as necessary.

Method 1

1. Add 1/8 cup (2 oz.) of **non-chlorine** bleach to one gallon of water and mix thoroughly.
2. Thoroughly wet the canvas and then gently scrub the stained area with the weak bleach solution.
3. Rinse with cold water to remove all of the solution.

Method 2

1. Add 1/2 cup (4 oz.) of **non-chlorine** bleach and 1/2 cup (4 oz.) Ivory Flakes to one gallon of water and mix thoroughly.
2. Soak the canvas in this solution for about 20 minutes.
3. Rinse with cold water to remove all of the solution.

Clear Vinyl Care

CAUTION

- **NEVER** store the clear vinyl pieces wet, as this will cause a milky film to develop.
- **NEVER** fold or crease the clear vinyl pieces as cracking will occur.
- Clear vinyl is *not* intended for use when the boat is in storage or being moored.
- Clear vinyl *does not* hold up well against ultraviolet rays.
- Under direct sunlight conditions, do **NOT** let the clear vinyl touch the framework. The framework radiates heat and can burn the clear vinyl.

- After each use, especially in saltwater, rinse the clear vinyl with cold freshwater.
- **Before** stowing, the clear vinyl must be completely dry. Air drying is best, but you can also carefully dry the vinyl with a chamois or soft cotton cloth.
- The clear vinyl can be rolled or laid out flat for stowage.
- **Never** fold or crease the clear vinyl parts as cracking will occur.

Cleaning Clear Vinyl

Regularly clean the clear vinyl to prevent dirt, pollen, and etc. from marring the surface. Generally, it is easiest to clean the clear vinyl while it is installed on the boat.

1. Hose down the clear vinyl with freshwater.
 2. Using a soft cotton cloth (**paper towels are abrasive and should never be used on clear vinyl**), gently wash the clear vinyl with soap and water.
 3. Rinse thoroughly to remove the soap.
 4. **Before** stowing, the clear vinyl must be completely dry. Air drying is best, but you can also carefully dry the vinyl with a chamois or soft cotton cloth.
- Ask your dealer about products available to keep the clear vinyl polished and looking new.

NEVER FOLD OR CREASE CLEAR VINYL!
FOLDING OR OTHERWISE CREASING CLEAR VINYL WILL CAUSE DAMAGE SUCH AS CRACKING TO OCCUR

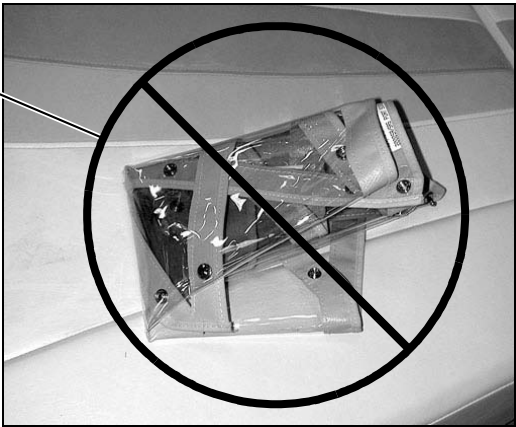

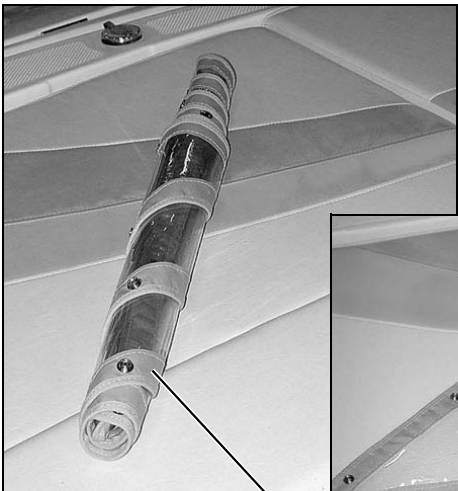

AFTER CLEAR VINYL PARTS HAVE COMPLETELY AIR DRIED THEY CAN BE ROLLED OR SIMPLY LAID FLAT FOR STOWAGE

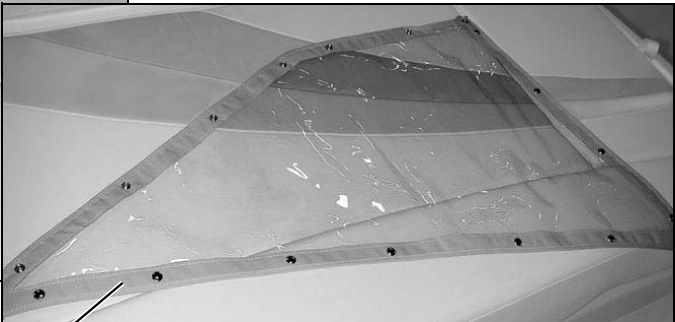

Chapter 8: Entertainment System

Audio System (If Equipped)

NOTICE

AM radio reception may be impaired anytime the engine is running.

Read the instruction manual for your boat's audio system *before* using.

Chapter 9: Convertible Seats

Sleeper Seats (180 Only)

- The sleeper seats can be adjusted fore and aft in the upright, operating position.
- The seat bottoms adjust into backrests when the seats are in the lounge position.

Operating Positions

To slide the seat forward:

1. Lift the forward seat at point (A).
2. Push down on the forward seat at point (B) and pull the seat forward.
3. Lock the forward seat into the desired position by pushing down at point (A).
4. Lift the aft seat at point (C).
5. Push down on the aft seat at point (D) and push the seat forward until the aft seat back is flush against the forward seat back.
6. Lock the aft seat into position by pushing down at point (C).

To slide the seat aft, repeat the steps above, but start with the aft seat.

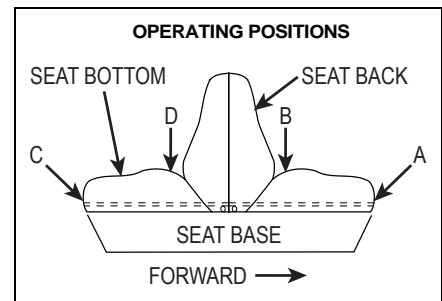

Lounge positions

To adjust into the flat lounge position:

1. Lift the forward seat at point (A).
2. Push down on the forward seat at point (B) and pull the seat forward until the seat back and bottom are flat.
3. Lift the aft seat at point (C).
4. Push down on the aft seat at point (D) and pull the seat aft until the seat back and bottom are flat.

To adjust into the chaise lounge position:

1. Lift up on the forward or aft seat bottom at point (A or C) and push the seat bottom down into the locked position.
2. To lower the seat bottom, lift the seat at point (A or C). Drop the seat bottom flat while holding the seat down at point (E).

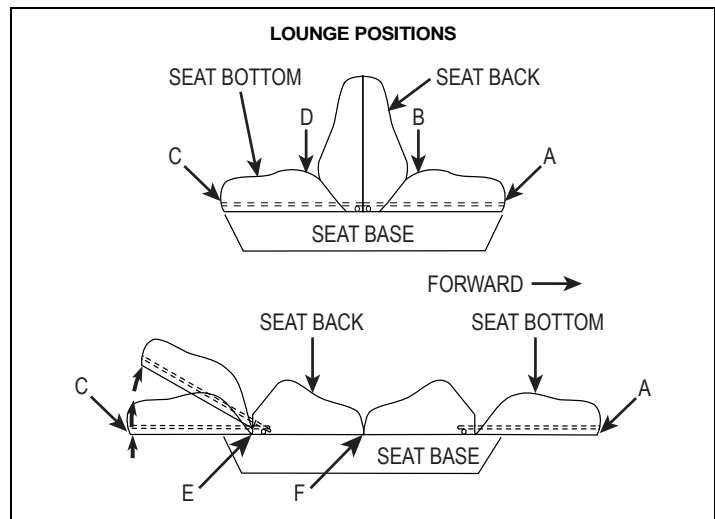

To return the seats to the operating position:

1. Lift the seat backs at point (F) and push down on the back edge of the seat bottom (B) and then seat bottom (D).
2. Push the seat bottoms towards the center of the seat until the seat backs are flush against each other and locked into place.

Removable Fishing Seat (184 Only)

⚠ **DANGER!**

PERSONAL SAFETY HAZARD!

- Do **NOT** allow anyone to ride on parts of the boat *not* designated for such use.
- Sitting on the fishing seat while underway is especially hazardous and **WILL** cause personal injury or death.

Remove and stow the fishing seat in a safe and secure area **before** getting under way or trailering your boat.

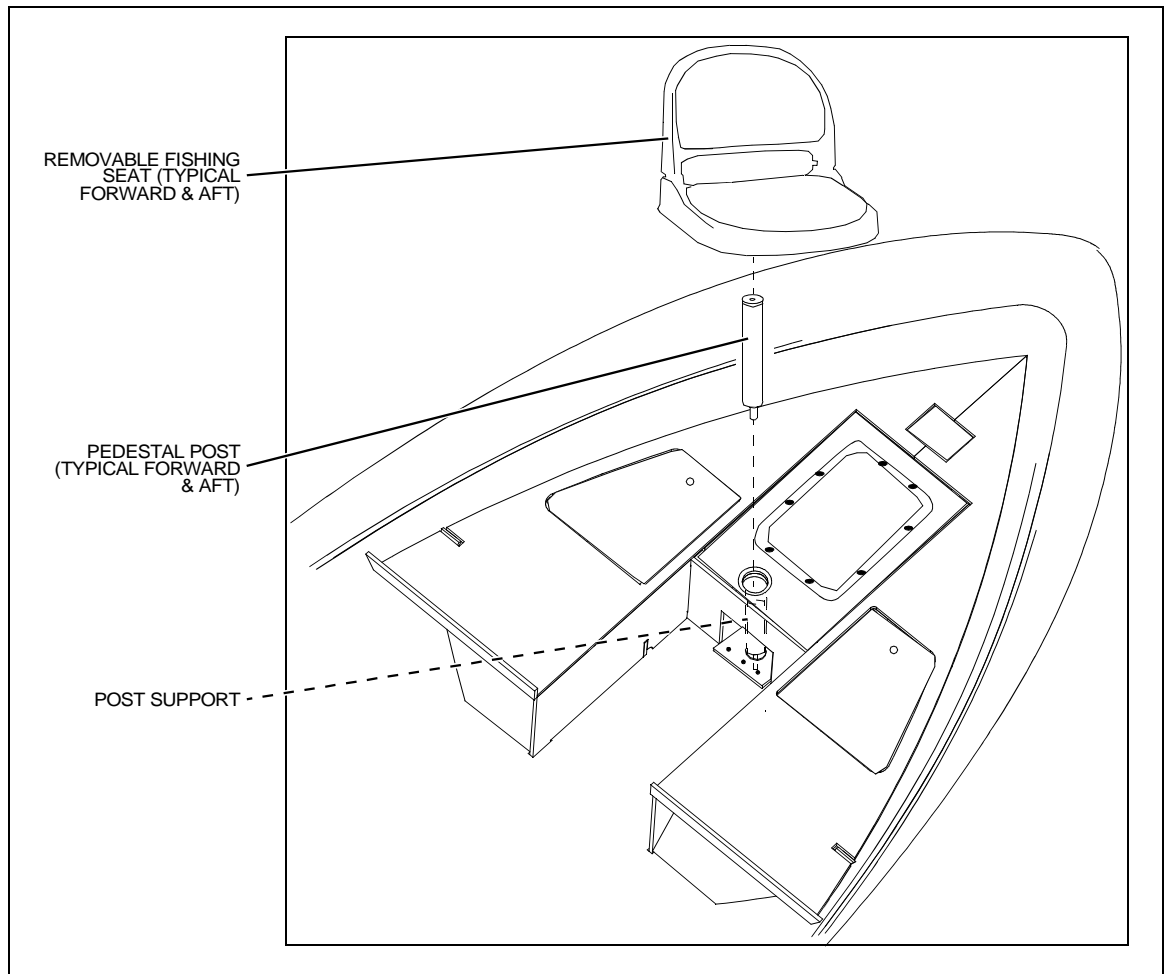

Chapter 10: Lights

Care and Maintenance

All of the lights installed on your boat are of top quality, but you should be aware that failure may periodically occur for a variety of reasons:

1. There may be a blown fuse - *replace the fuse.*
2. The bulb may be burned out - *carry spare bulbs for replacement.*
3. A wire may be damaged or may have come loose - *repair as required.*
4. The bulb base may be corroded - *clean the base and coat it with non-conductive electrical lubricant.*

Lights



CAUTION

- Be conservative in the use of battery power.
- Prolonged use of cabin interior lights (overnight) *will* result in a drained battery.

- The lights are powered by the boat's 12-volt DC system.
- The battery switch *must* be turned *On* for the lights to work.

Navigation Lights







CAUTION!

Avoid the storage of gear where it would block navigation lights from view.

Read the navigation light section in the *Sport Boat Owner's Manual*.

Chapter 11: Electrical System





 **DANGER!**

EXTREME FIRE, SHOCK & EXPLOSION HAZARD!

- To minimize the risks of fire and explosion, *NEVER* install knife switches or other arcing devices in the fuel compartments.
- NEVER* substitute automotive parts for marine parts. Electrical, ignition and fuel system parts were designed and manufactured to comply with rules and regulations that minimize risks of fire and explosion.
- Do *NOT* modify the electrical systems or relevant drawings.
- Have qualified personnel install batteries and/or perform electrical system maintenance.

 **WARNING!**

FIRE & EXPLOSION HAZARD!

- Fuel fumes are heavier than air and *will* collect in the bilge areas where they can be accidentally ignited.
- Visually and by smell (sniff test), check the engine and fuel compartments for fumes or accumulation of fuel.
- NEVER* expose the batteries to open flame or sparks, and *NEVER* smoke anywhere near the batteries.

 **CAUTION**



SHOCK & ELECTRICAL SYSTEM DAMAGE HAZARD!

When the engine is running, *NEVER* disconnect the battery cables. Doing either could cause damage to your boat's engine and/or electrical system.

NOTICE

Electrical connections are prone to corrosion. To reduce corrosion caused electrical problems:

- Keep *all* electrical connections clean.
- Apply a spray-on protectant that is designed to protect connections from corrosion.

12-Volt DC System

Battery

The battery supplies electricity for lights, 12-Volt accessories, and engine and starting.

The Electrical section of Chapter 8, in the *Sport Boat Owner's Manual*, provides battery care and maintenance instructions.

Fuses and Circuit Breakers

- Push-to reset circuit breakers for main accessory power are at the helm
- Some equipment may have secondary fuse protection at the unit, or at the battery.
- See the *Locations* section of this *Supplement* for the location of the trolling motor push-to-reset circuit breakers (184 only).

12-Volt Accessory Outlet(s)

 CAUTION
Do NOT use the 12-volt accessory outlet with a cigarette or cigar lighter. High temperatures may melt the outlet.

- Your boat is equipped with one or more 12-volt accessory outlets.
- The outlet(s) can be used with any 12-volt device which draws 10-amps or less.
- Each 12-volt accessory outlet is protected by a 10-amp fuse on the push-to-reset circuit breaker at the helm.

Alternator

The alternator will keep the battery properly charged when the engine is running at cruising speeds.

Electrical Routings

160 Deck Electrical Harnesses

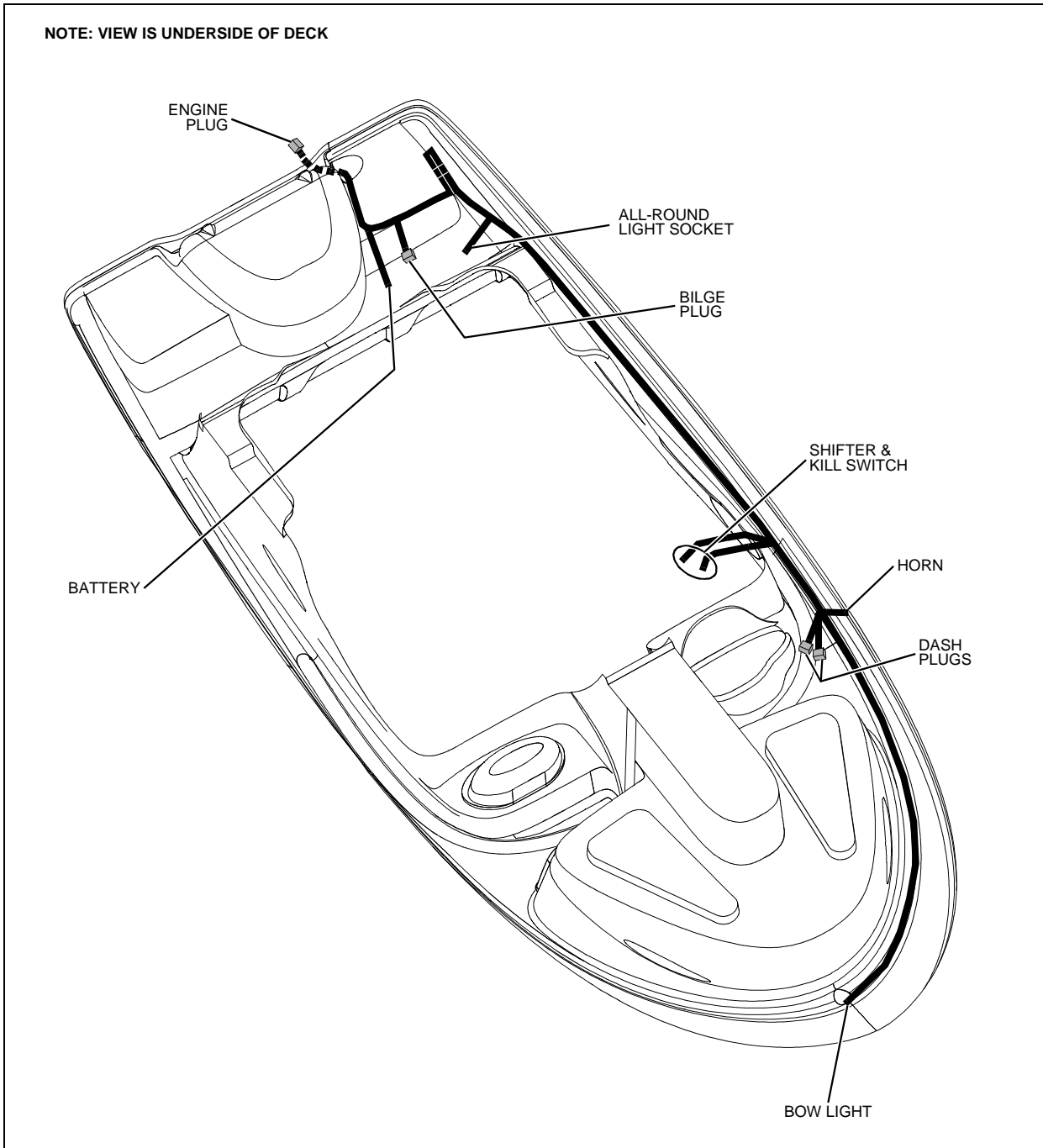

180 Deck Electrical Harnesses

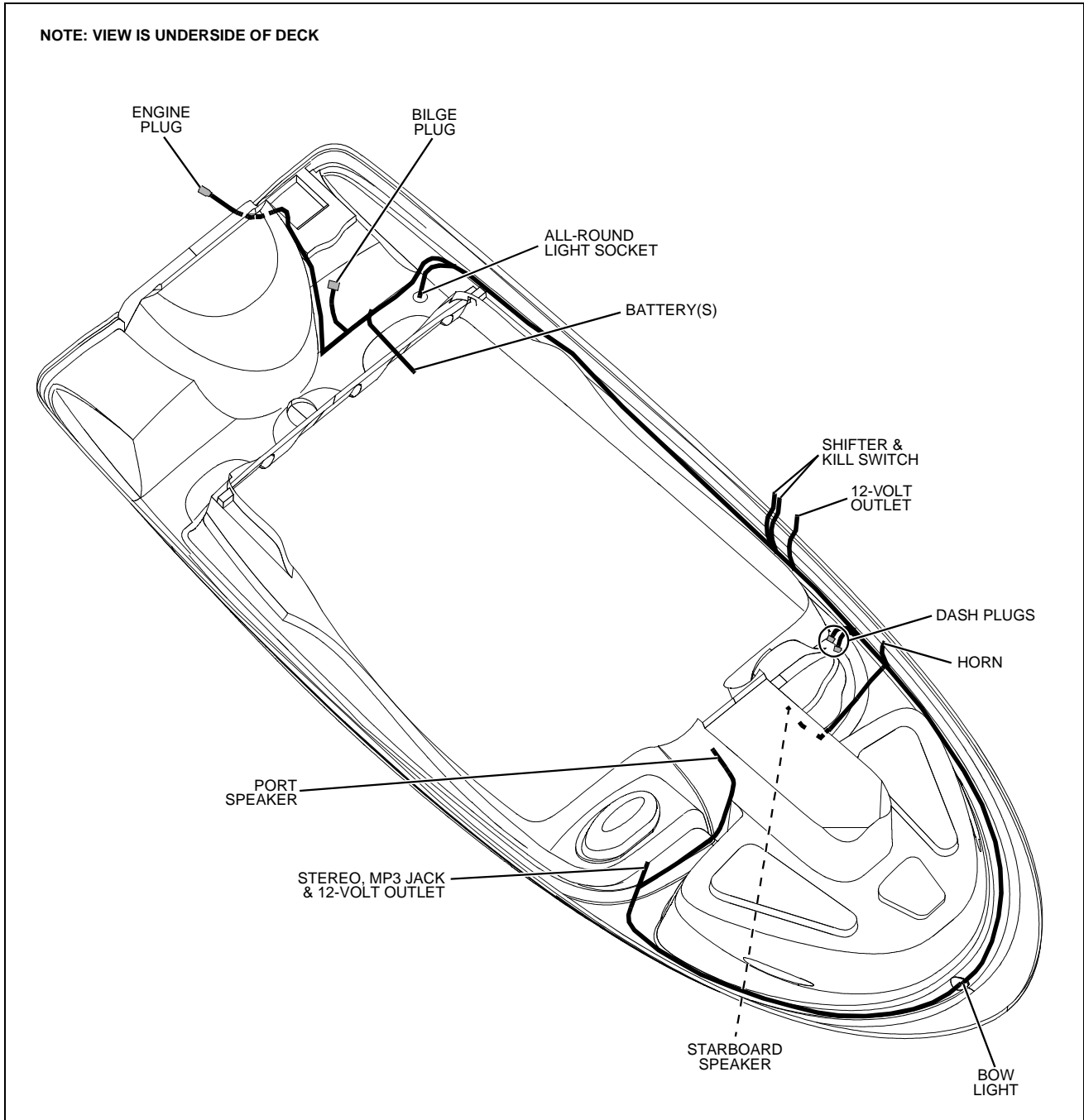

184 Deck Electrical Harnesses

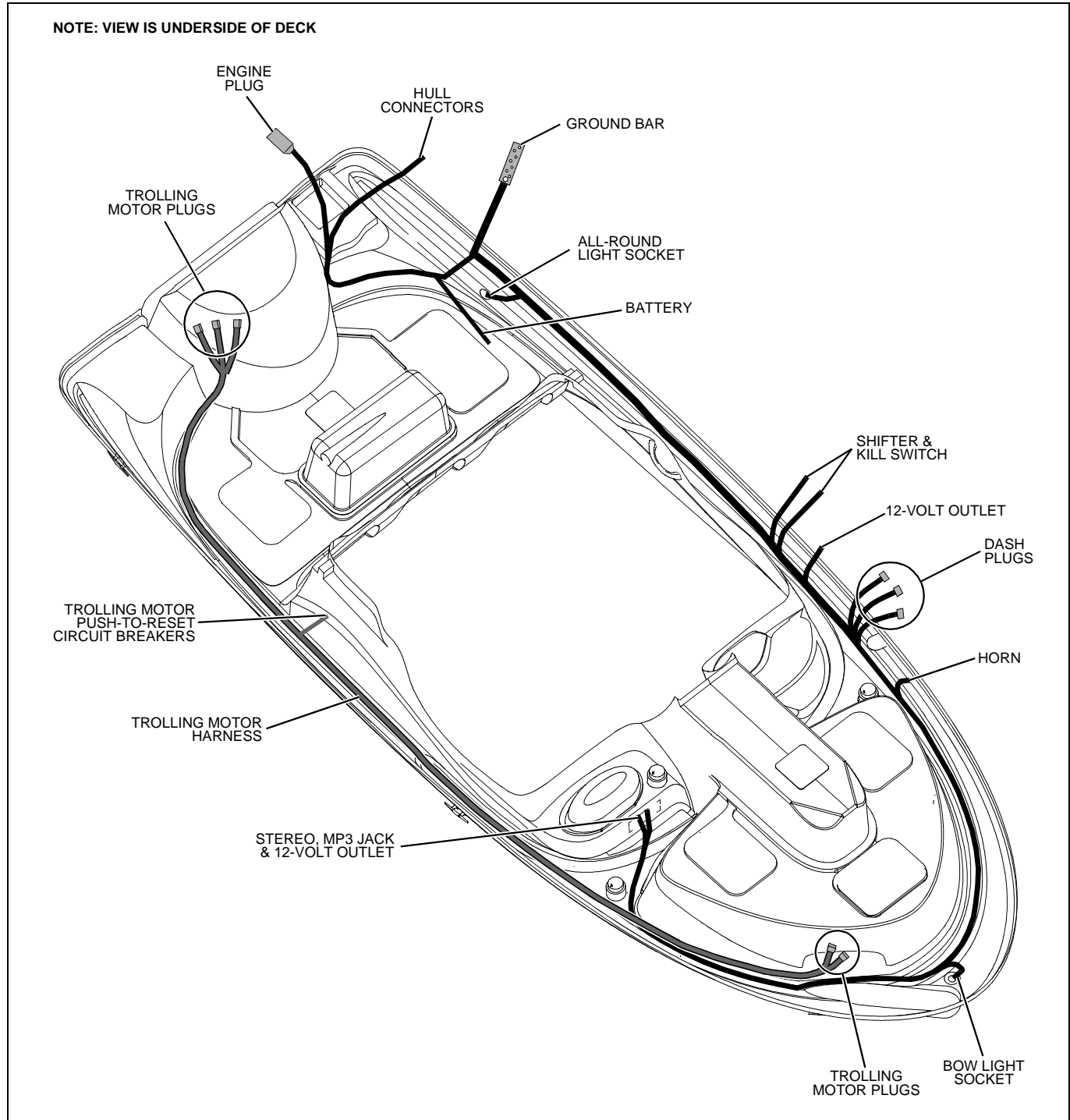

160 Hull Electrical Harness

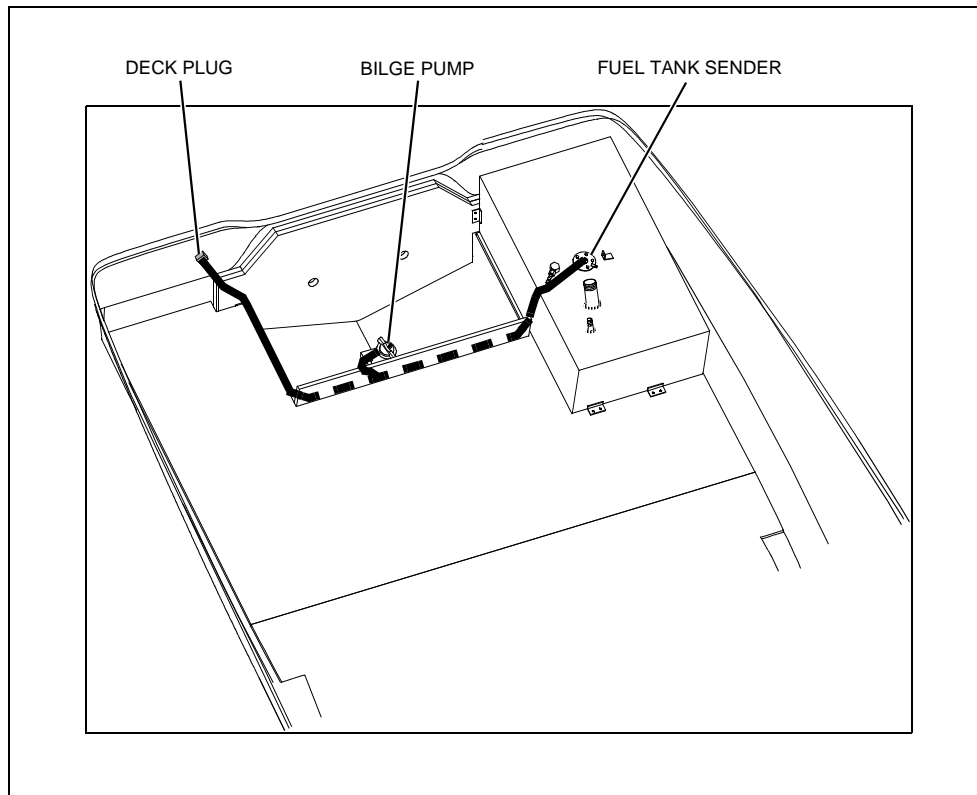

180 & 184 Hull Electrical Harness

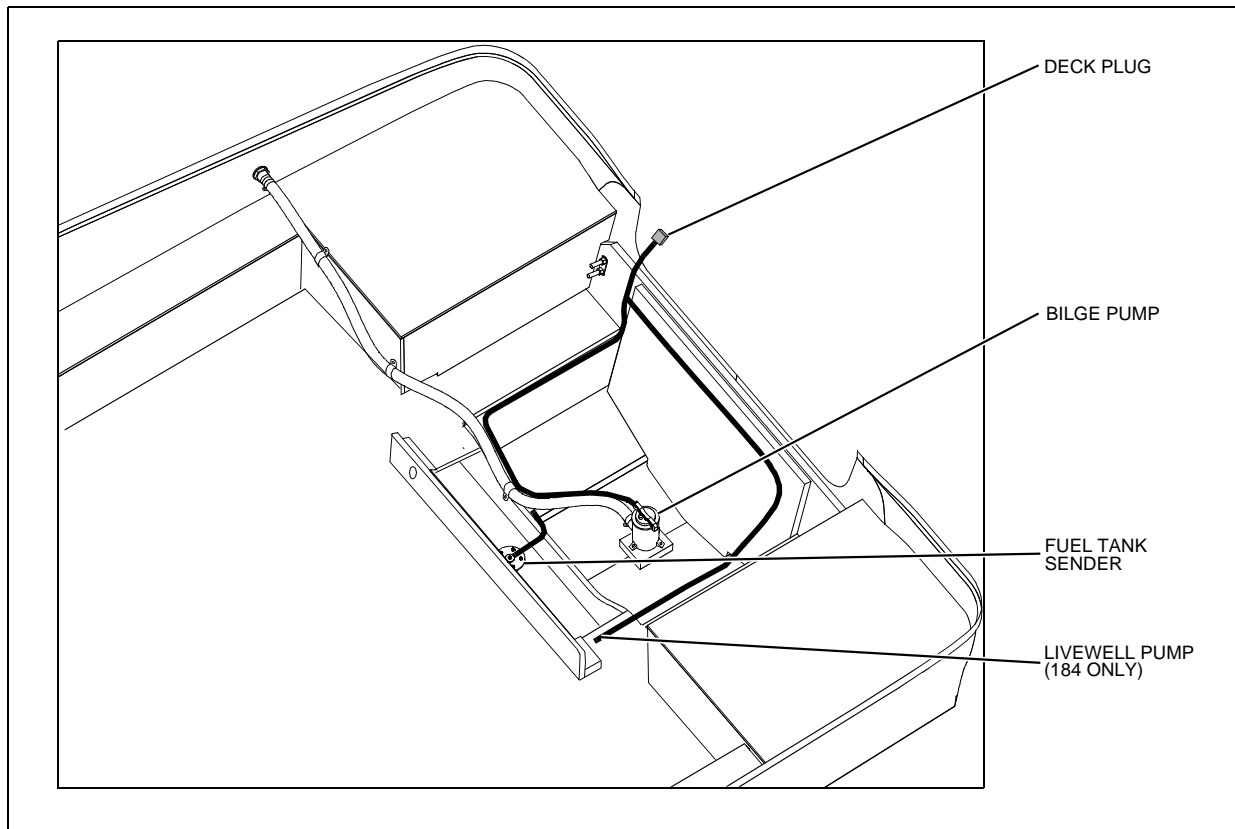

Wiring Diagrams

160 & 180 Engine Electrical System

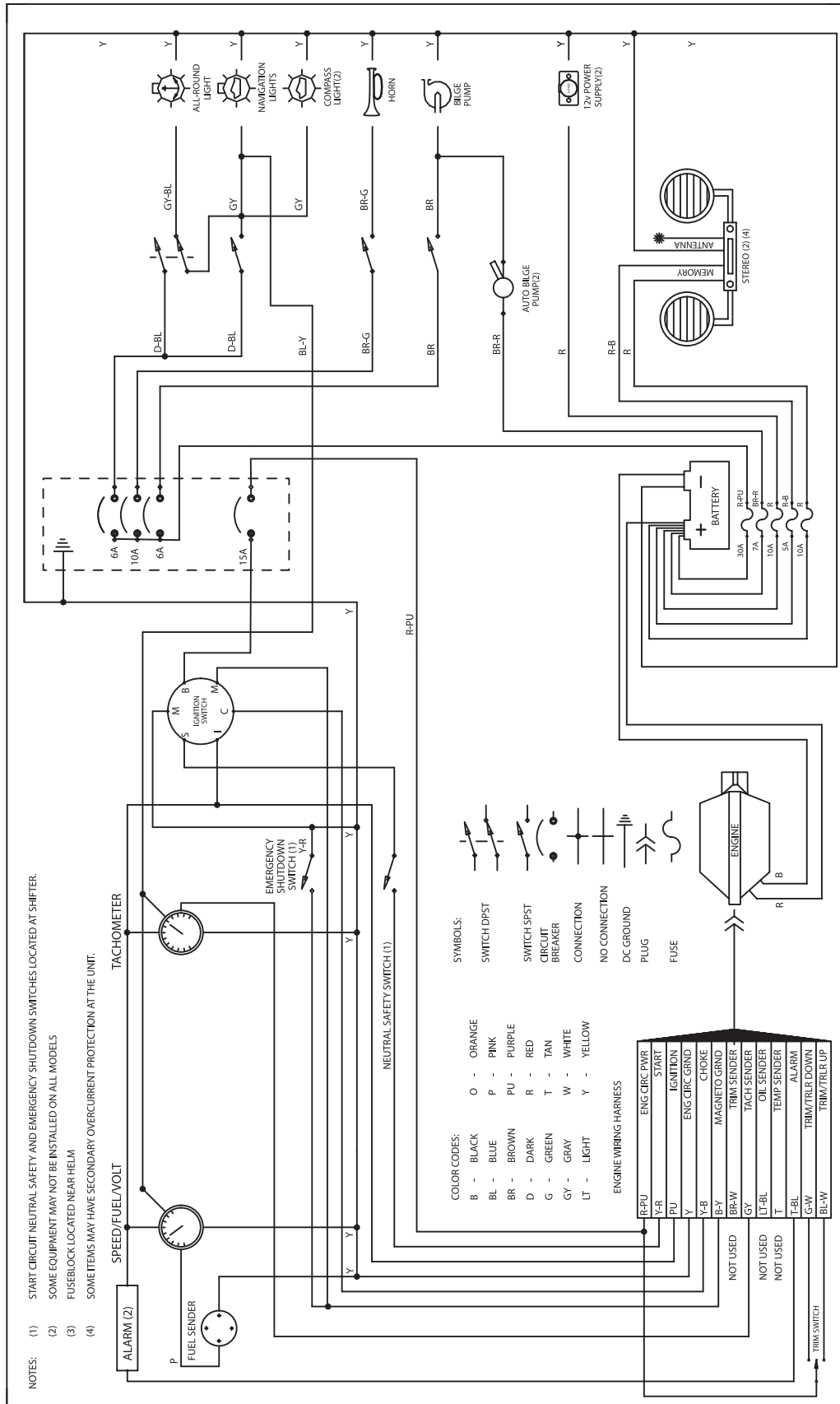

184 Engine Electrical System

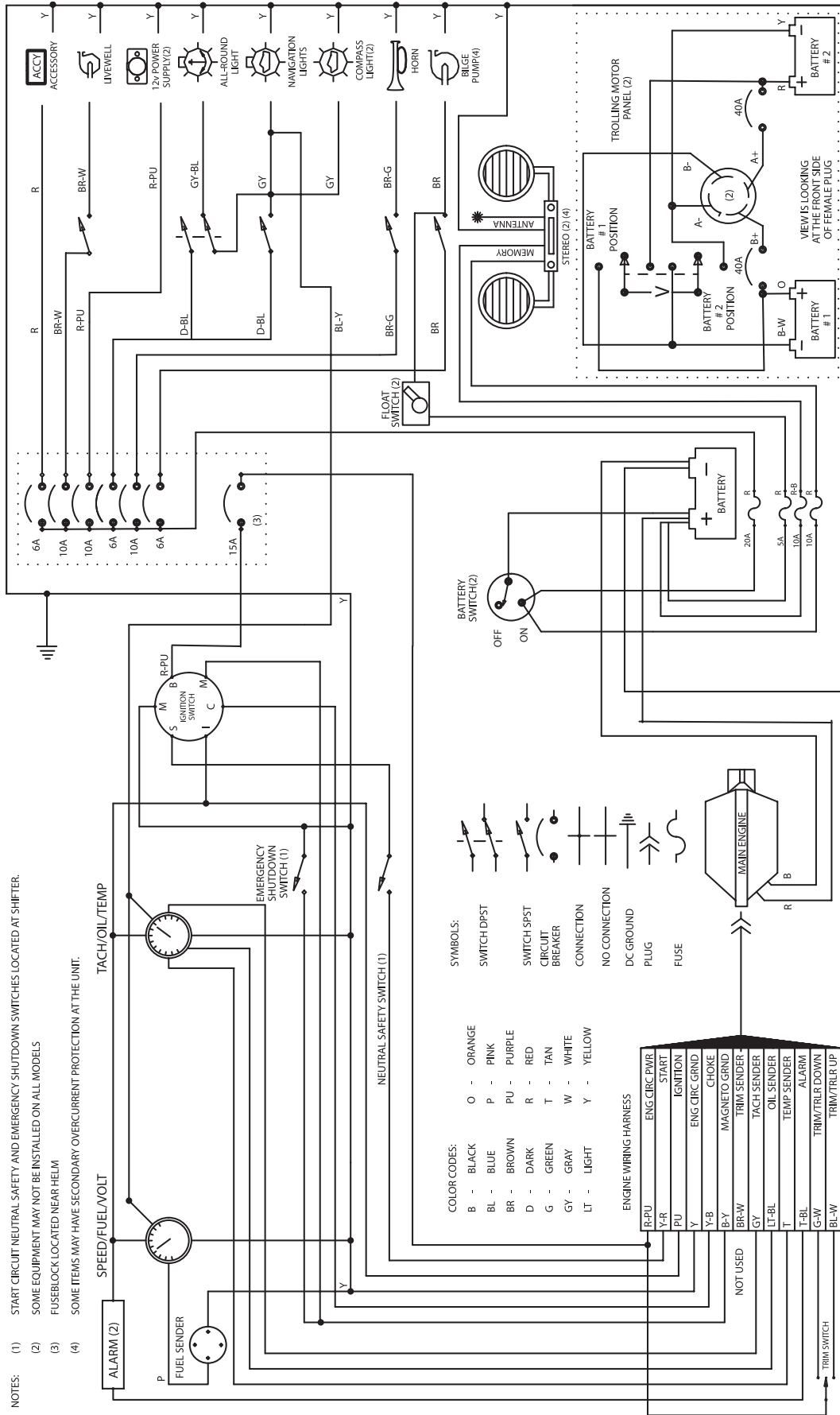

Trolling Motor Harness (184 Only)

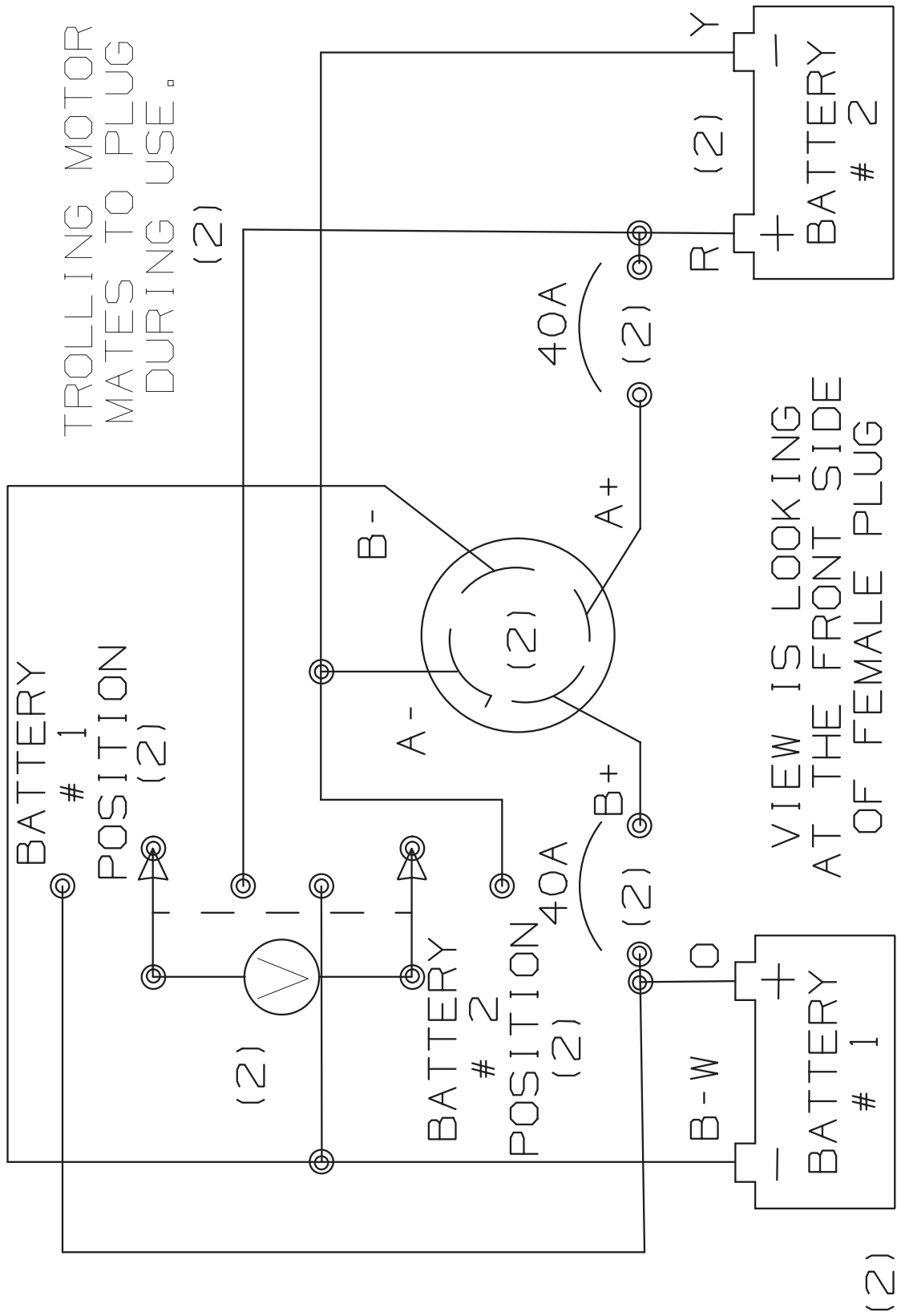

Important Records

Selling Dealer

Name Of Dealership

Address

Phone/FAX/E-mail

Sales Manager

Service Manager

Key Numbers

Ignition

Other

Electronics

Manufacturer

Model Name/Number

Serial Number

Manufacturer

Model Name/Number

Serial Number

Manufacturer

Model Name/Number

Serial Number

Manufacturer

Model Name/Number

Serial Number

Manufacturer

Model Name/Number

Serial Number

Engine

Manufacturer

Model Name/Number

Engine Serial Number

Oil Type/SAE

Quarts per Engine

Filter Type

Propeller

Manufacturer

Pitch

Model Number

Float Plan

Before going boating, fill out a copy of this float plan (or similar) and leave it with a *reliable* person whom you can depend on to contact the Coast Guard or other rescue organization, if you do not return as scheduled.

Description of Boat

Registration/Documentation Number		
Length	Make	Type
Hull Color		Trim Color
Fuel Capacity	Engine Type	Number of Engines
Distinguishing Features		
Distinguishing Features		

Persons Onboard

Full Name		
Age	Health	Phone Number
Full Name		
Age	Health	Phone Number
Full Name		
Age	Health	Phone Number
Full Name		
Age	Health	Phone Number
Full Name		
Age	Health	Phone Number
Full Name		
Age	Health	Phone Number

Operator of Boat

Full Name		
Male or Female	Age	Health
Address		
Address		
Phone/FAX/E-mail		
Operator's Experience		

Survival Equipment

Marine Radio (Yes/No)	Type	Frequencies
Number of PFDs	Flares (Yes/No)	Mirror (yes or no)
Smoke Signals (Yes/No)	Flashlight (Yes/No)	Food (Yes/No)
Water (Yes/No)	Anchor (Yes/No)	Raft/Dinghy (Yes/No)
Paddles (Yes/No)	EPIRB (Yes/No)	Other
Other	Other	Other

Vehicle Description

Make	Model
Color	License Number
Where is the Vehicle Parked?	

Trip Expectations

Departing From	
Departure Date	Departure Time
Stopover 1	
Arrive No Later Than: Date	Arrive No Later Than: Time
Stopover 2	
Arrive No Later Than: Date	Arrive No Later Than: Time
Stopover 3	
Arrive No Later Than: Date	Arrive No Later Than: Time
Stopover 4	
Arrive No Later Than: Date	Arrive No Later Than: Time
Stopover 5	
Arrive No Later Than: Date	Arrive No Later Than: Time
Stopover 6	
Arrive No Later Than: Date	Arrive No Later Than: Time
Final Destination Port (If Different Than Home Port)	
Arrive No Later Than: Date	Arrive No Later Than: Time

If not returned by the date and time listed above, call the Coast Guard or other local authority.

Coast Guard Phone Number
Local Authority Phone Number

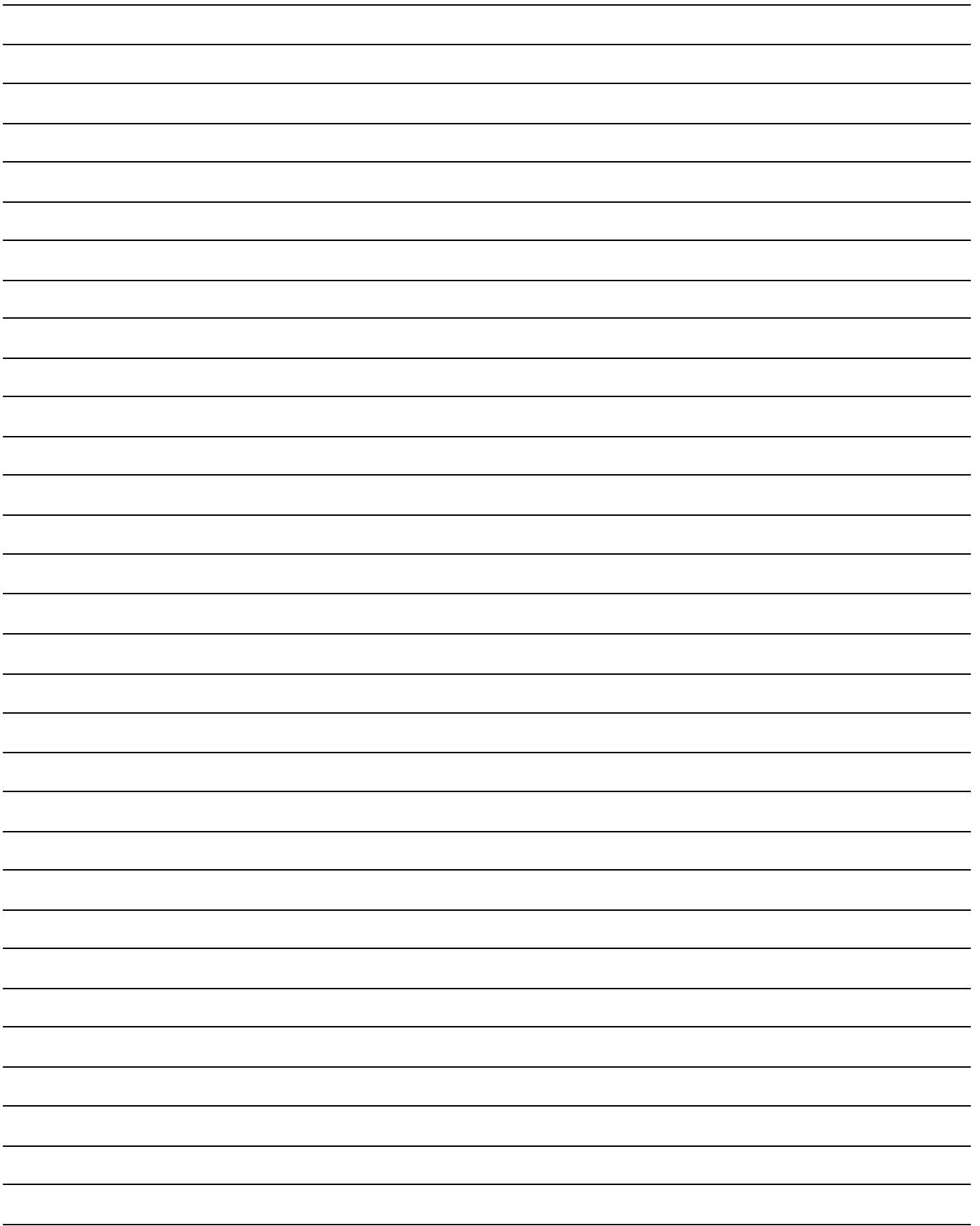

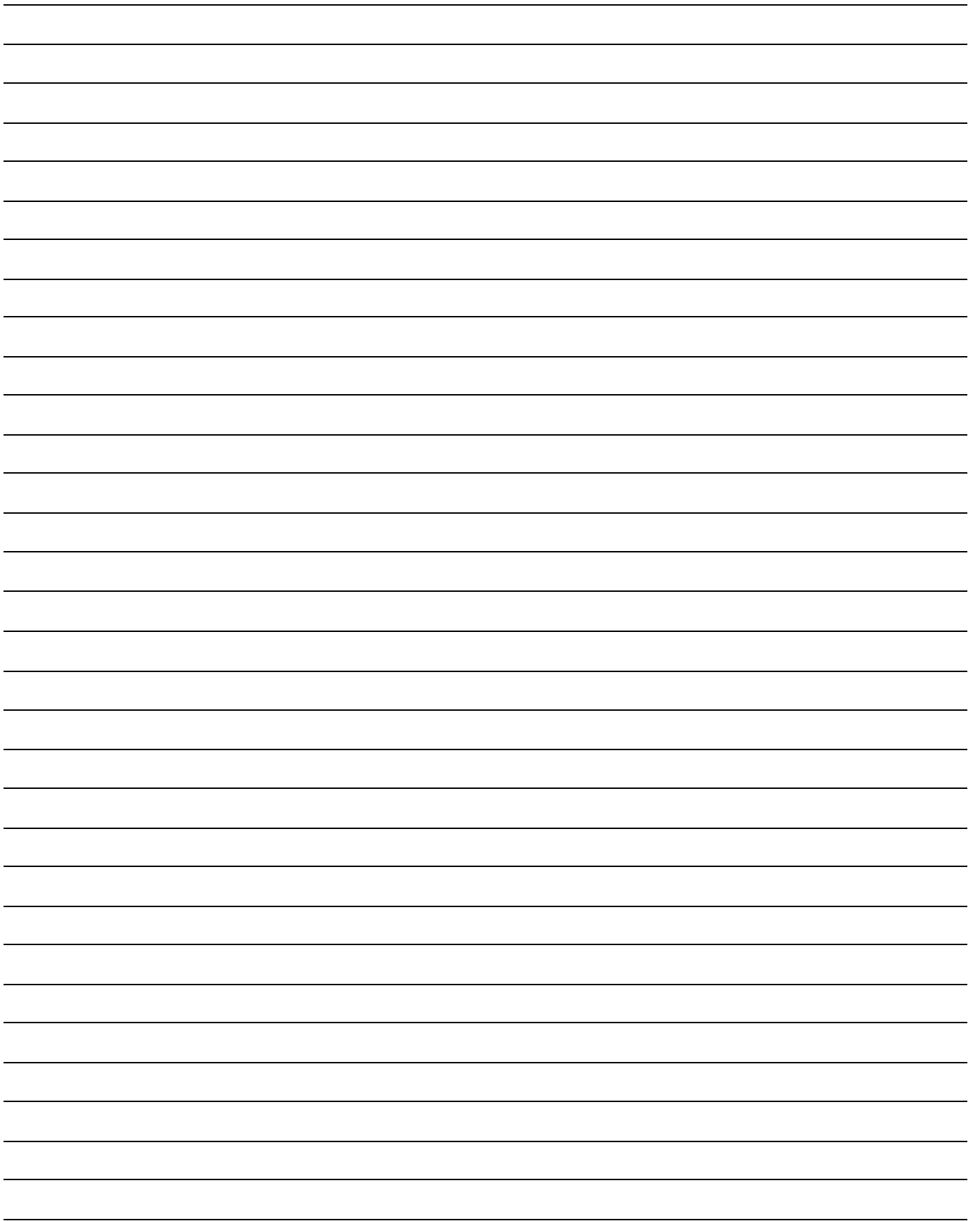

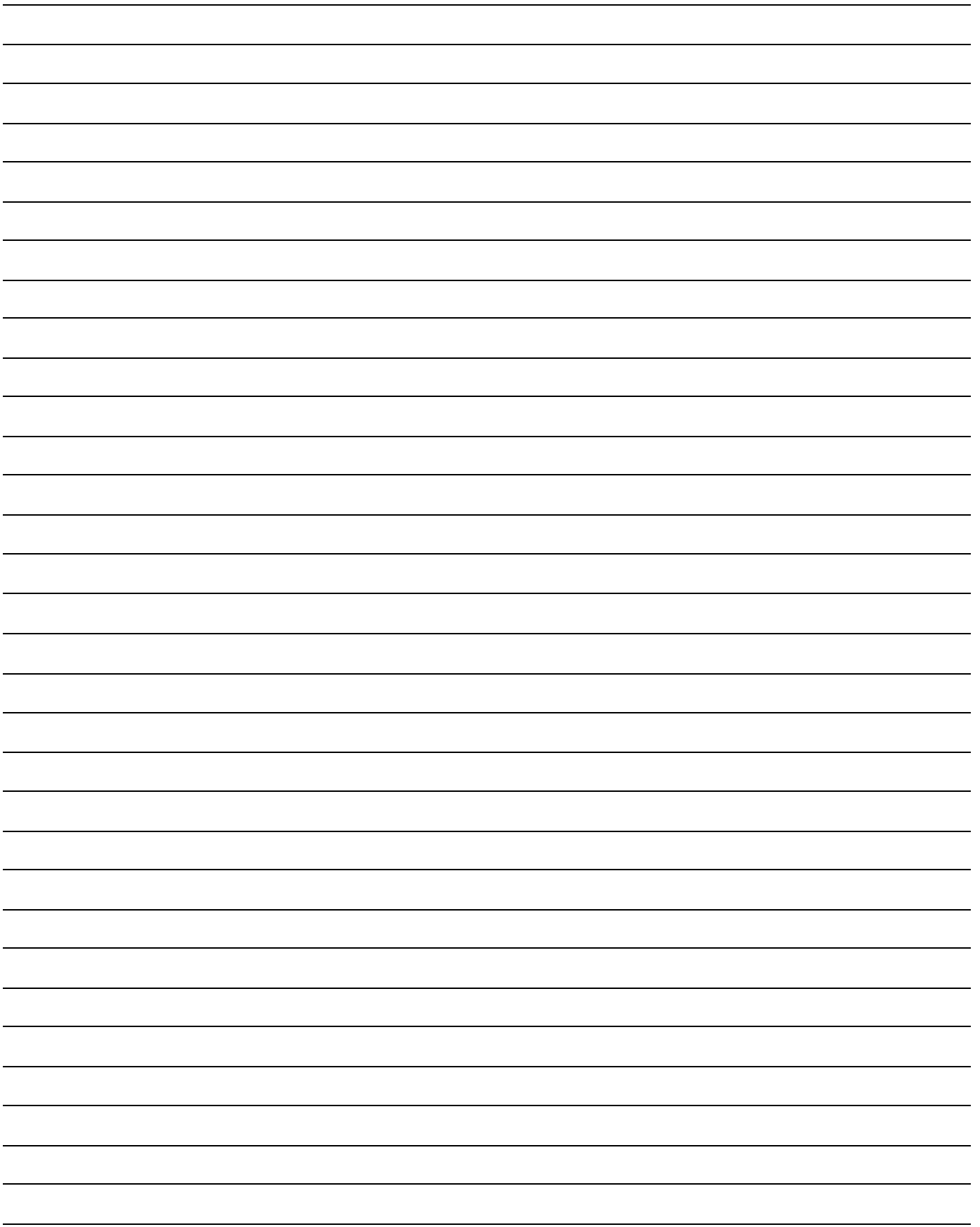

Part Number 1787653

Bayliner • P.O. Box 9029 • Everett, WA 98206 • 360-435-5571