

BAYLINER[®]

160, 180, & 184

Owner's Manual *Supplement*

Engine Serial Number: _____

Hull Identification Number: _____

Hull Identification Number

The Hull Identification Number (HIN) is located on the starboard side of the transom. Be sure to record the HIN (and the engine serial numbers) in the space provided above. Please refer to the HIN for any correspondence or orders.

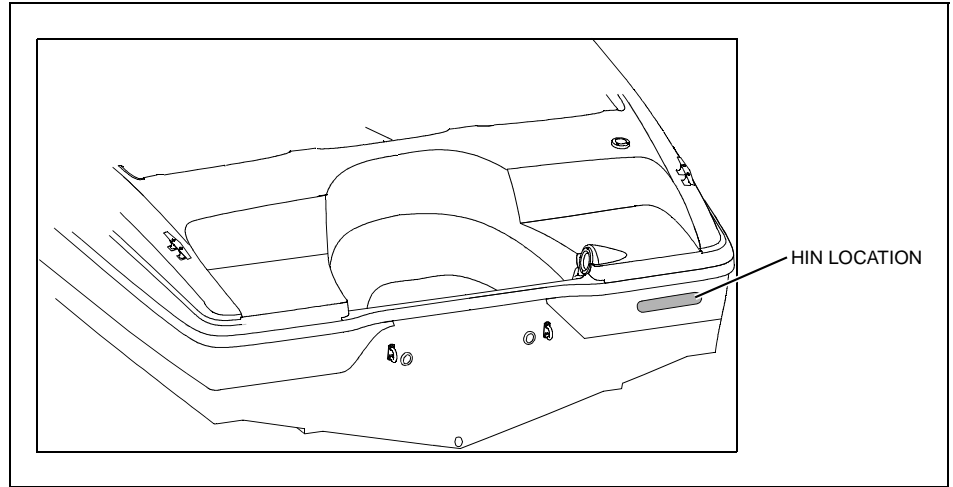

© 2003 Bayliner Technical Publications. All rights reserved.

No part of this publication may be reproduced, stored in any retrieval system, or transmitted in any form by any means, electronic, mechanical, photocopying, recording or otherwise, without prior written permission of Bayliner.
Printed in the United States of America.

General Notes

The material in this document is for information only and is subject to change without notice. While reasonable efforts have been made in the preparation of this document to assure its accuracy, Bayliner assumes no liability resulting from errors or omissions in this document, or from the use of information contained herein. Due to our commitment to product improvement, Bayliner reserves the right to make changes in the product design, specifications, and equipment at any time without notice or obligation. Illustrations and/or photos may show optional equipment.
All Bayliner products meet or exceed USCG (United States Coast Guard) and/or NMMA (National Marine Manufacturer's Association) construction standards. Manufactured with 1,1,1 Trichloroethane, a substance which harms public health and environment during the manufacturing process by destroying ozone in the upper atmosphere.

Proprietary Rights

This document discloses subject matter in which Bayliner has proprietary rights. The information and design disclosed herein were originated by and are the property of Bayliner. Neither receipt nor possession thereof confers or transfers any right to reproduce, copy, alter or disclose the document or any part thereof, any information contained therein, or to construct boats or any item from it, except by written permission from or written agreement with Bayliner. This document is to be returned upon request to Bayliner.

CONTENTS

1 Chapter 1: Welcome Aboard!

- 1 Dealer Service
- 1 Warranty Information
- 1 Boating Experience
- 2 Safety Standards
- 2 Engine & Accessories Guidelines
- 3 Engine & Accessories Literature
- 3 Qualified Maintenance
- 3 Special Care For Moored Boats
- 4 Carbon Monoxide (CO)
 - 4 *Facts about CO*
 - 5 *Where and How CO Can Accumulate*
 - 5 *How to Protect Yourself and Others From CO*
 - 6 *Trip Checklist*
 - 6 *Monthly Checklist*
 - 6 *Annual Checklist*
 - 6 *Carbon Monoxide Alarm System*
 - 7 *More Information*

8 Chapter 2: Product Specifications

- 8 160
- 8 180
- 9 184

10 Chapter 3: Locations

- 10 Exterior Views
 - 10 *Hull Views*
 - 11 *160 Deck View*
 - 12 *180 Deck View*
 - 13 *184 Deck View*
- 14 Component Locations

15 Chapter 4: Propulsion & Related Systems

- 15 Engine
- 15 Fuel System
 - 16 *Fuel Fill and Vent*
 - 16 *Fuel Filters*

17 Chapter 5: Controls

- 17 Steering
- 17 Shift/Throttle Lever
- 17 Power Trim and Tilt

18 Chapter 6: Plumbing

- 18 Bilge Pump
- 19 Seawater System (184 Only)
 - 19 *Seacock*
- 20 Baitwell System (184 Only)

21 Chapter 7: Deck Equipment

- 21 Cleats and Tow Eyes
- 21 Pre-rigging For Trolling Motor (184 Only)
- 22 Ski Pylon (If Equipped)
- 23 Canvas (If Equipped)
 - 23 *180 Canvas Top (If Equipped)*
 - 24 *184 Canvas Top (If Equipped)*
 - 25 *180 Bimini Top (If Equipped)*
 - 26 *184 Bimini Top (If Equipped)*

27 Chapter 8: Entertainment Systems

27 Audio System (If Equipped)

28 Chapter 9: Convertible Seats

28 Sleeper Seats (If Equipped)

28 *Operating Positions*

28 *Lounge positions*

29 Removable Fishing Seats (184 Only)

30 Chapter 10: Lights

30 Care and Maintenance

30 Navigation Lights

31 Chapter 11: Electrical System

32 12-Volt DC System

32 *Battery*

32 *Fuses and Circuit Breakers*

32 *Alternator*

32 *12-Volt Accessory Outlet (If Equipped)*

33 Electrical Routings

33 *160 Deck Electrical Harness*

34 *180 Deck Electrical Harness*

35 *184 Deck Electrical Harness*

36 *160 Hull Electrical Harness*

36 *180 & 184 Hull Electrical Harness*

37 Wiring Diagrams

38 *184*

39 *Trolling Motor Harness (184 Only)*

40 Important Records

41 Float Plan

Hazard Boxes & Symbols

The hazard boxes and symbols shown below are used throughout this supplement to call attention to potentially dangerous situations which could lead to either personal injury or product damage. **Read ALL warnings carefully and follow all safety instructions.**

 **DANGER!**
This box alerts you to immediate hazards which *WILL* cause severe personal injury or death if the warning is ignored.

 **WARNING!**
This box alerts you to hazards or unsafe practices which *COULD* result in severe personal injury or death if the warning is ignored.

 **CAUTION!**
This box alerts you to hazards or unsafe practices which *COULD* result in minor personal injury or cause product or property damage if the warning is ignored.

NOTICE
This box calls attention to installation, operation or maintenance information, which is important to proper operation but is not hazard related.

 FIRE HAZARD!	 EXPLOSION HAZARD!	 NO OPEN FLAME!	 ELECTRICAL HAZARD!	 HOT HAZARD!
---	--	---	--	--

 FALLING HAZARD!	 ROTATING PROPELLER HAZARD!	 RUN BILGE BLOWERS FOR 4 MINUTES!
--	---	--

DANGER
CARBON MONOXIDE
CO POISONING HAZARD!

Chapter 1: Welcome Aboard!

This *Owner's Manual Supplement* provides specific information about your boat that is **not** covered in the *Sport Boat Owner's Manual*. Please study the *Sport Boat Owner's Manual* and this *Supplement* carefully. Keep the *Sport Boat Owner's Manual* and this *Supplement* on your boat in a secure, yet readily available place.

Dealer Service

- Ask your dealer to explain **all** systems **before** taking delivery of your boat.
- Your dealer is your key to service.
- Contact your dealer if you have any problems with your new boat.
- If your dealer cannot help, call our customer service hotline: 360-435-8957 or send us a FAX: 360-403-4235.
- Buy replacement parts from any authorized Bayliner dealer.

Warranty Information

- Bayliner offers a Limited Warranty on each new Bayliner purchased through an authorized Bayliner dealer.
- A copy of the Limited Warranty was included in your owner's packet.
- If you did **not** receive a copy of the Limited Warranty, please contact your dealer or call 360-435-8957 for a copy.

Boating Experience

 **WARNING!**

CONTROL HAZARD!

A qualified operator *must* be in control of the boat at *all* times. *DO NOT* operate your boat while under the influence of alcohol or drugs.

If this is your first boat or if you are changing to a type of boat you are **not** familiar with, for your own comfort and safety, obtain handling and operating experience **before** assuming command of the boat.

Take one of the boating safety classes offered by the U.S. Power Squadrons or the U.S. Coast Guard Auxiliary. For more course information, including dates and locations of upcoming classes, contact the organizations directly:

- U.S. Power Squadrons: 1-888-FOR-USPS (1-888-367-8777) or on the Internet at: <http://www.usps.org>
- U.S. Coast Guard Auxiliary: 1-800-368-5647 or on the Internet at: <http://www.cgaux.org>

Outside the United States, your selling dealer, national sailing federation or local boat club can advise you of local sea schools or competent instructors.

Safety Standards

⚠ DANGER!





FALLING and ROTATING PROPELLER HAZARD!

NEVER allow anyone to ride on parts of the boat *not* designed for such use.

- **Sitting on seat backs, lounging on the forward deck, bow riding, gunwale riding or occupying the transom platform while underway is especially hazardous and *will* cause personal injury or death.**

⚠ DANGER!





ROTATING PROPELLER and CARBON MONOXIDE POISONING HAZARD!

- ***NEVER*** allow anyone to occupy, or hang from, the back deck or swim platform while the engine(s) are running.
- **Teak surfing, dragging, or water skiing within 20 feet of a moving watercraft can be fatal.**

⚠ DANGER!

PERSONAL SAFETY HAZARD!

ALWAYS secure the anchor and other loose objects *before* getting underway. The anchor and other items that are *not* properly secured can come loose when the boat is moving and cause personal injury or death.

- Your boat's mechanical and electrical systems were designed to meet safety standards in effect at the time it was built.
- Some of these standards were mandated by law, all of them were designed to insure your safety, and the safety of other people, vessels and property.

In addition to this *Owner's Manual Supplement*, please read the *Sport Boat Owner's Manual* and *all* accessory instructions for important safety standards and hazard information.

Engine & Accessories Guidelines

NOTICE

When storing your boat please refer to your engine's operation and maintenance manuals.

- Your boat's engine and accessories were selected to provide optimum performance and service.
- Installing a different engine or other accessories may cause unwanted handling characteristics.
- Should you choose to install a different engine or to add accessories that will affect the boat's running trim, have an experienced marine technician perform a safety inspection and handling test before operating your boat again.

Certain modifications to your boat *will* result in cancellation of your warranty protection. *Always* check with your dealer *before* making any modifications to your boat.

Engine & Accessories Literature

- The engine and accessories installed on your boat come with their own operation and maintenance manuals.
- Read and understand these manuals *before* using the engine and accessories.
- Unless noted otherwise, *all* engine and accessory literature referred to in this supplement is included in your owner's packet.

Qualified Maintenance



WARNING!

To maintain the integrity and safety of your boat, allow *only* qualified personnel to perform maintenance on, or in any way modify: The steering system, propulsion system, engine control system, fuel system, environmental control system, electrical system or navigational system.

- Failure to maintain your boat's systems (listed in the warning above) as designed could violate the laws in your jurisdiction and could expose you and other people to the danger of bodily injury or accidental death.
- Follow the instructions provided in the *Sport Boat Owner's Manual*, this *Owner's Manual Supplement*, the engine owner's manual and *all* accessory instruction sheets and manuals.

Special Care For Moored Boats

NOTICE

- To help seal the hull bottom and reduce the possibility of gelcoat blistering on moored boats, apply an epoxy barrier coating. The barrier coating should be covered with several coats of anti-fouling paint.
- Many states regulate the chemical content of bottom paints in order to meet environmental standards. Check with your local dealer about recommended bottom paints, and about the laws in effect in your area.

- Whether moored in saltwater or freshwater, your boat *will* collect marine growth on its hull bottom.
- This *will* detract from the boat's beauty, greatly affect its performance and may damage the gelcoat.
- Periodically haul the boat out of the water and scrub the hull bottom with a bristle brush and a solution of soap and water.

Carbon Monoxide (CO)

⚠ DANGER!	
	<ul style="list-style-type: none"> • Carbon monoxide gas (CO) is colorless, odorless, tasteless, and extremely dangerous. • <i>All</i> engines, generators, and fuel burning appliances produce CO as exhaust. • Prolonged exposure to low concentrations or very quick exposure to high concentrations <i>will</i> cause BRAIN DAMAGE or DEATH. • Teak surfing, dragging, or water skiing within 20 feet of a moving watercraft can be fatal.

Facts about CO

- CO poisoning causes a significant number of boating deaths each year.
- Called the "silent killer", CO is an extremely toxic, colorless, odorless and tasteless gas.
- CO can harm or even kill you inside or outside your boat.
- CO can affect you whether you're underway, moored, or anchored.
- CO symptoms are similar to seasickness or alcohol intoxication.
- CO can make you sick in seconds. In high enough concentrations, even a few breaths can be fatal.
- Breathing CO blocks the ability of your blood to carry oxygen.
- The effects are cumulative, even low levels of exposure can result in injury or death.

Factors That Increase the Effects of CO Poisoning

- Age
- Smokers or people exposed to high concentrations of cigarette smoke
- Consumption of alcohol
- Lung disorders
- Heart problems
- Pregnancy

Where and How CO Can Accumulate

Stationary Conditions That Increase CO Accumulations Include:

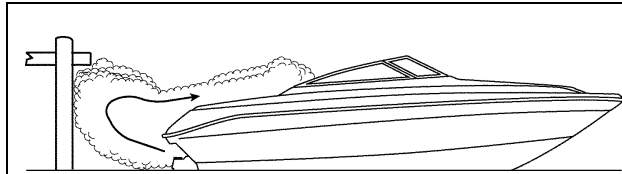

A. Using engine, generator, or other fuel burning device when boat is moored in a confined space.

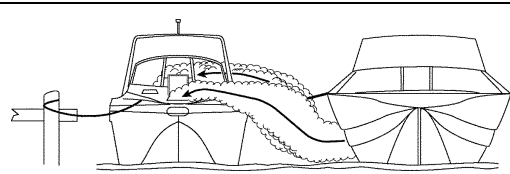

B. Mooring too close to another boat that is using its engine, generator, or other fuel burning device.

To correct stationary situations A and/or B:

- Close **all** windows, portlights and hatches.
- If possible, move your boat away from source of CO.

Running Conditions That Increase CO Accumulations Include:

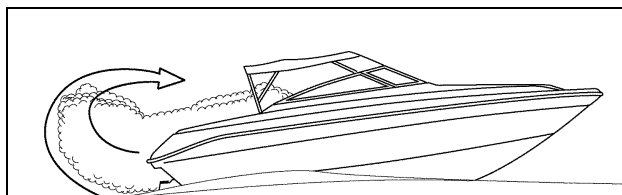

C. Running boat with trim angle of bow too high.

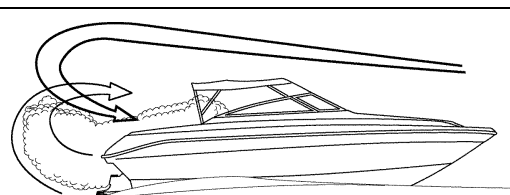

D. Running boat without through ventilation (station wagon effect).

To correct running situations C and/or D:

- Trim bow down.
- **Open** windows and canvas.
- When possible, run boat so that prevailing winds help dissipate exhaust.

How to Protect Yourself and Others From CO

- Know where and how CO may accumulate in and around your boat (see above).
- Maintain fresh air circulation throughout the boat at **all** times.
- Know where your engine and generator exhaust outlets are located and keep everyone away from these areas.
- **Never** sit on, or hang onto, the back deck or swim platform while the engine(s) are running.
- **Never** enter the areas under swim platforms where exhaust outlets are located.
- Although CO can be present without the smell of exhaust fumes, if exhaust fumes are detected on the boat, take immediate action to dissipate these fumes.
- Treat symptoms of seasickness as possible CO poisoning. Get the person into fresh air immediately. Seek medical attention—unless you're sure it's **not** CO.
- Install and maintain CO alarms inside your boat. **Do not** ignore any alarm. Replace alarms as recommended by the alarm manufacturer.
- Follow the checklists provided on the next page.
- Get a Vessel Safety Check.

For information on how to get a free VESSEL SAFETY CHECK, visit www.vesselsafetycheck.org or contact your local U.S. Coast Guard Auxiliary or United States Power Squadrons®.

- U.S. Coast Guard Auxiliary: 1-800-368-5647 or on the Internet at: <http://www.cgaux.org>
- U.S. Power Squadrons: 1-888-FOR-USPS (1-888-367-8777) or on the Internet at: <http://www.usps.org>

Trip Checklist

- Make sure you know where the exhaust outlets are located on your boat.
- Educate *all* passengers about the symptoms of CO poisoning and where CO may accumulate.
- When docked, or rafted with another boat, be aware of exhaust emissions from the other boat.
- Confirm that water flows from the exhaust outlet when the engines and generator are started.
- Listen for any change in exhaust sound, which could indicate an exhaust component failure.
- Test the operation of each CO alarm by pressing the test button.

Monthly Checklist

- Make sure *all* exhaust clamps are in place and secure.
- Look for exhaust leaking from exhaust system components. Signs include rust and/or black streaking, water leaks, or corroded or cracked fittings.
- Inspect rubber exhaust hoses for burned, cracked, or deteriorated sections. *All* rubber hoses should be pliable and free of kinks.

Annual Checklist

Have a Qualified Marine Technician:

- Replace exhaust hoses if cracking, charring, or deterioration is found.
- Ensure that your engines and generators are properly tuned, and well maintained.
- Inspect each water pump impeller and the water pump housing. Replace if worn. Make sure cooling systems are in working condition.
- Inspect *all* metallic exhaust components for cracking, rusting, leaking, or loosening. Make sure they check the cylinder head gasket, exhaust manifold, water injection elbow, and the threaded adapter nipple between the manifold and the elbow.
- Clean, inspect, and confirm proper operation of the generator cooling water anti-siphon valve (if equipped).

Carbon Monoxide Alarm System

⚠ DANGER!	
	<p><i>CARBON MONOXIDE POISONING HAZARD!</i></p> <ul style="list-style-type: none"> • The house battery switch <i>must</i> be in the <i>On</i> position for the CO Monitors to work.

NOTICE
<p>The stereo memory and CO monitor(s) place a small, but constant drain on the battery. If your boat will be unattended for an extended amount of time, plug into shore power with the battery charger turned <i>On</i>, or disconnect the battery if shore power is <i>not</i> an option.</p>

- ***Do not*** disconnect the alarm system.
- Read and understand the manufacturer's instructions for your CO alarm system. If you did *not* receive an instruction manual, call (800) 383-0269 and one will be mailed to you.

If your boat is *not* equipped with a carbon monoxide alarm, consider purchasing one from your dealer or marine supply store.

More Information

For more information about how you can prevent carbon monoxide poisoning on recreational boats and other ways to boat more safely, contact:

United States Coast Guard

Office of Boating Safety (G-OPB-3)
2100 Second Street SW
Washington, DC 20593
www.uscgboating.org
1-800-368-5647

National Marine Manufacturers Association (NMMA)

200 East Randolph Drive
Suite 5100
Chicago, IL 60601-9301
www.nmma.org
312-946-6200

American Boat & Yacht Council, Inc. (ABYC)

3069 Solomon's Island Road
Edgewater, MD 21037-1416
www.abycinc.org
410-956-1050

For information on how to get a free VESSEL SAFETY CHECK, visit www.vesselsafetycheck.org or contact your local U.S. Coast Guard Auxiliary or United States Power Squadrons®.

- U.S. Coast Guard Auxiliary: 1-800-368-5647 or on the Internet at: <http://www.cgaux.org>
- U.S. Power Squadrons: 1-888-FOR-USPS (1-888-367-8777) or on the Internet at: <http://www.usps.org>

Chapter 2: Product Specifications

160

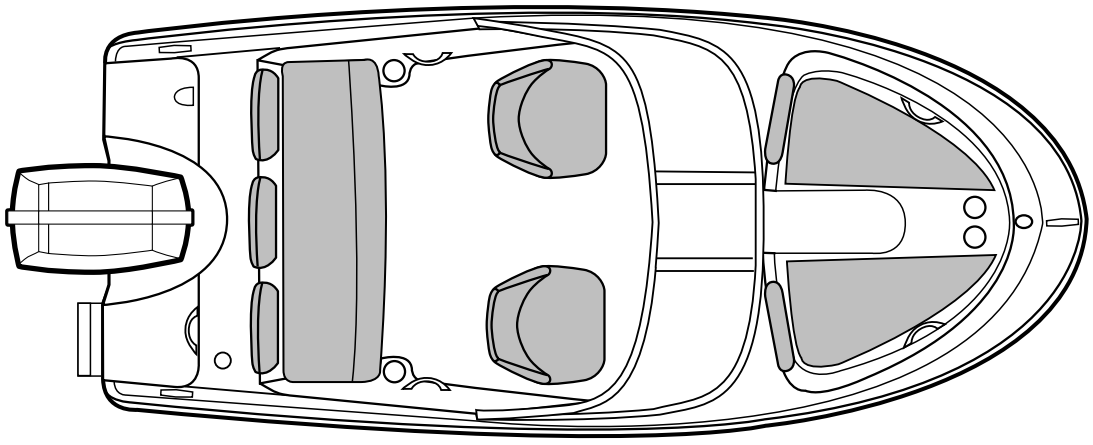

Overall Length	Bridge Clearance	Beam	Draft (Drive Up)	Draft (Drive Down)	Fuel Capacity (gal.)
16' 2"	3' 5"	7' 2"	1' 2"	2' 7"	18

180

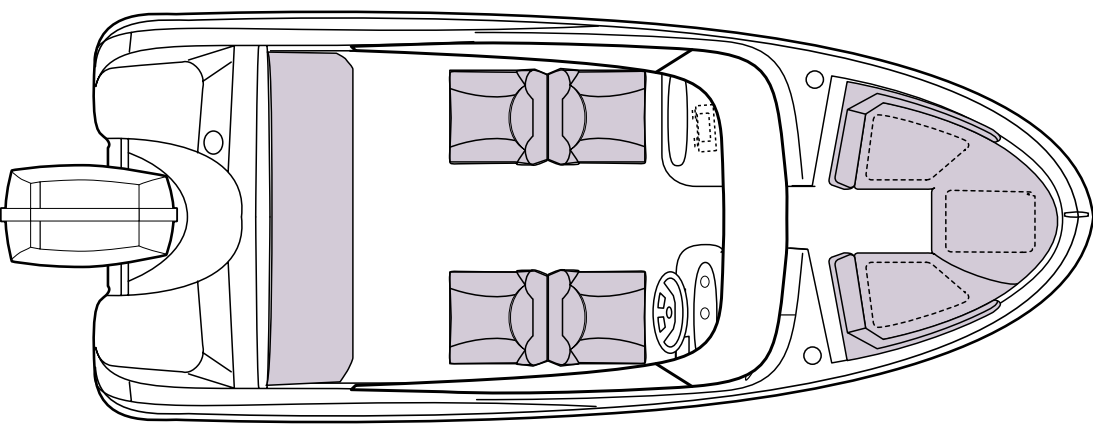

Overall Length	Bridge Clearance	Beam	Draft (Drive Up)	Draft (Drive Down)	Fuel Capacity (gal.)
18' 0"	3' 10"	7' 6"	1' 2"	2' 7"	23

184

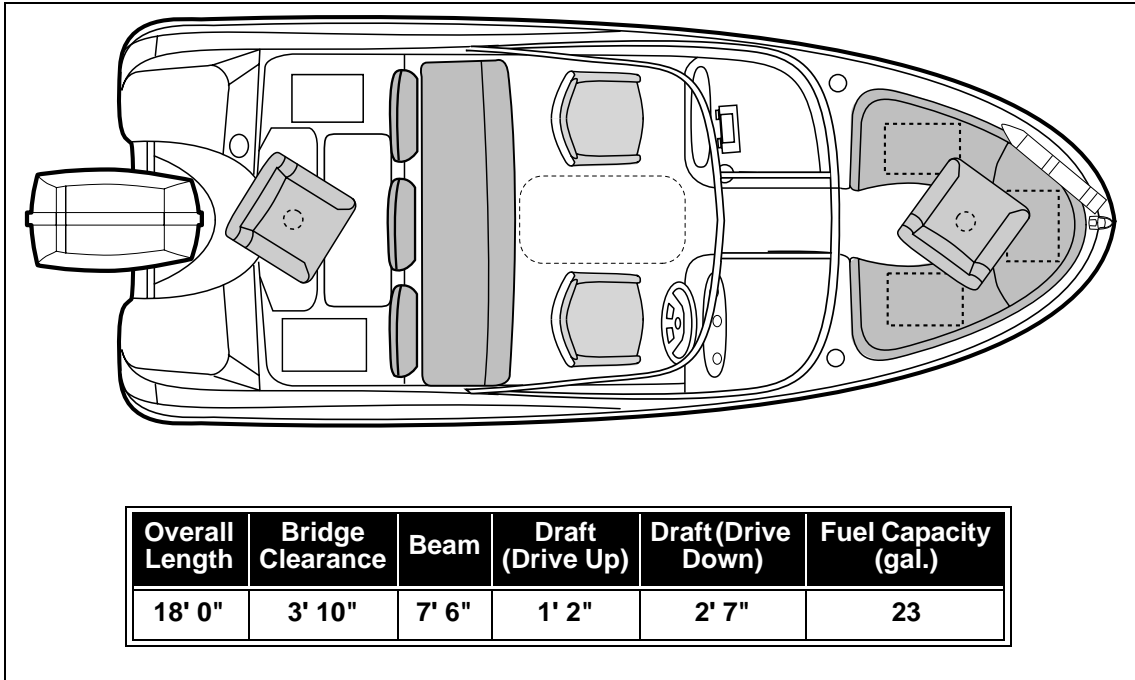

Chapter 3: Locations

Exterior Views

Hull Views

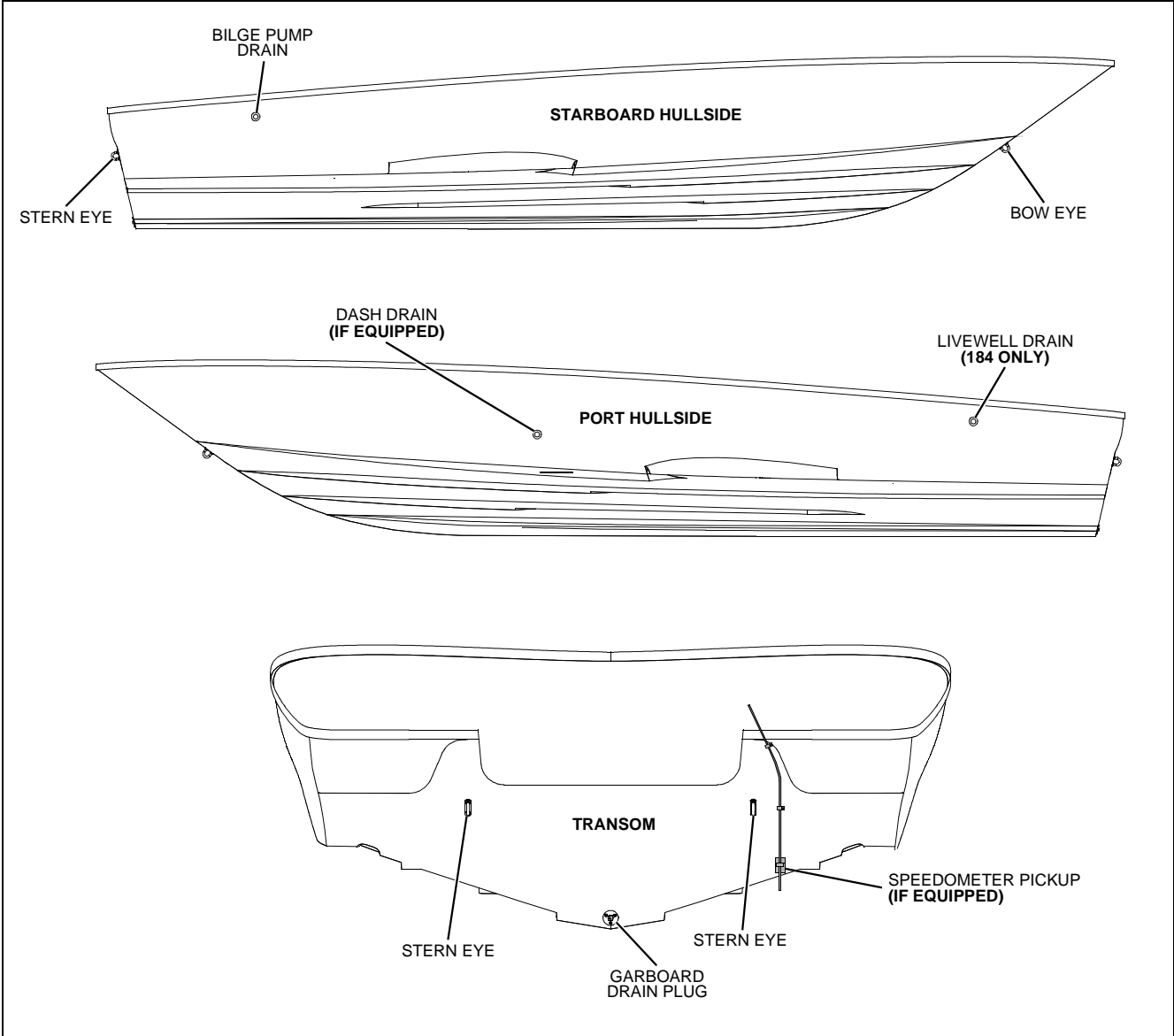

160 Deck View

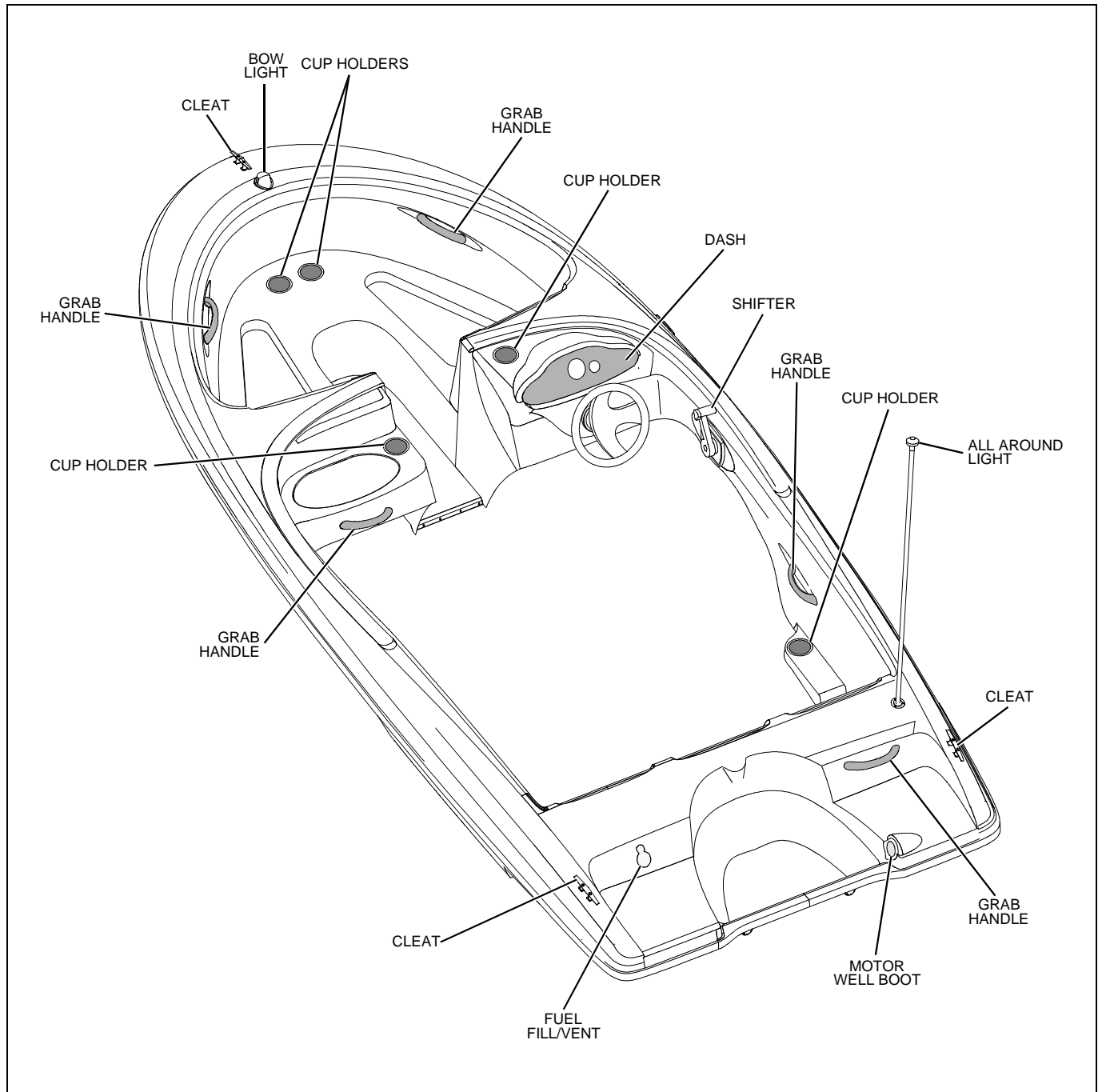

180 Deck View

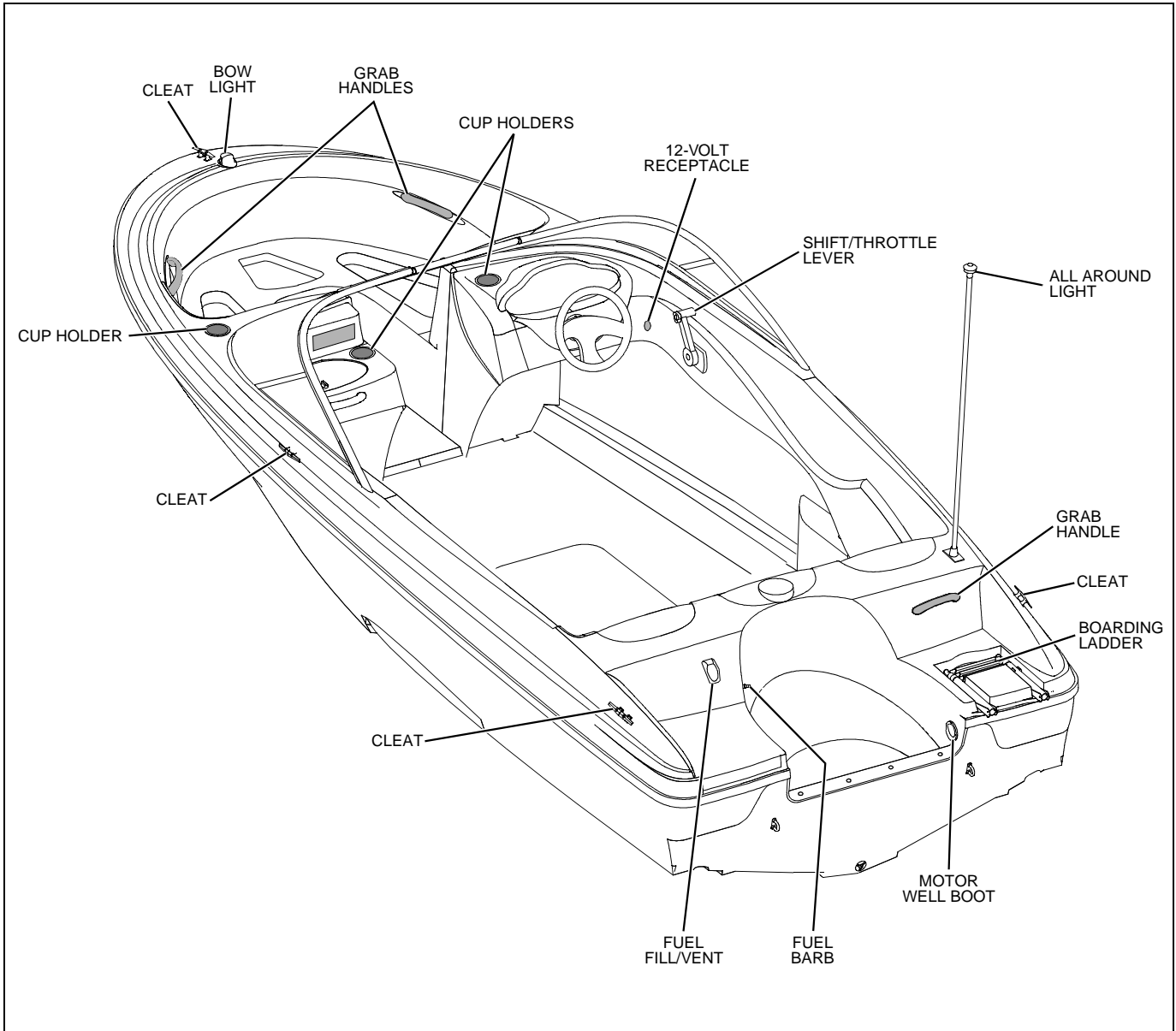

184 Deck View

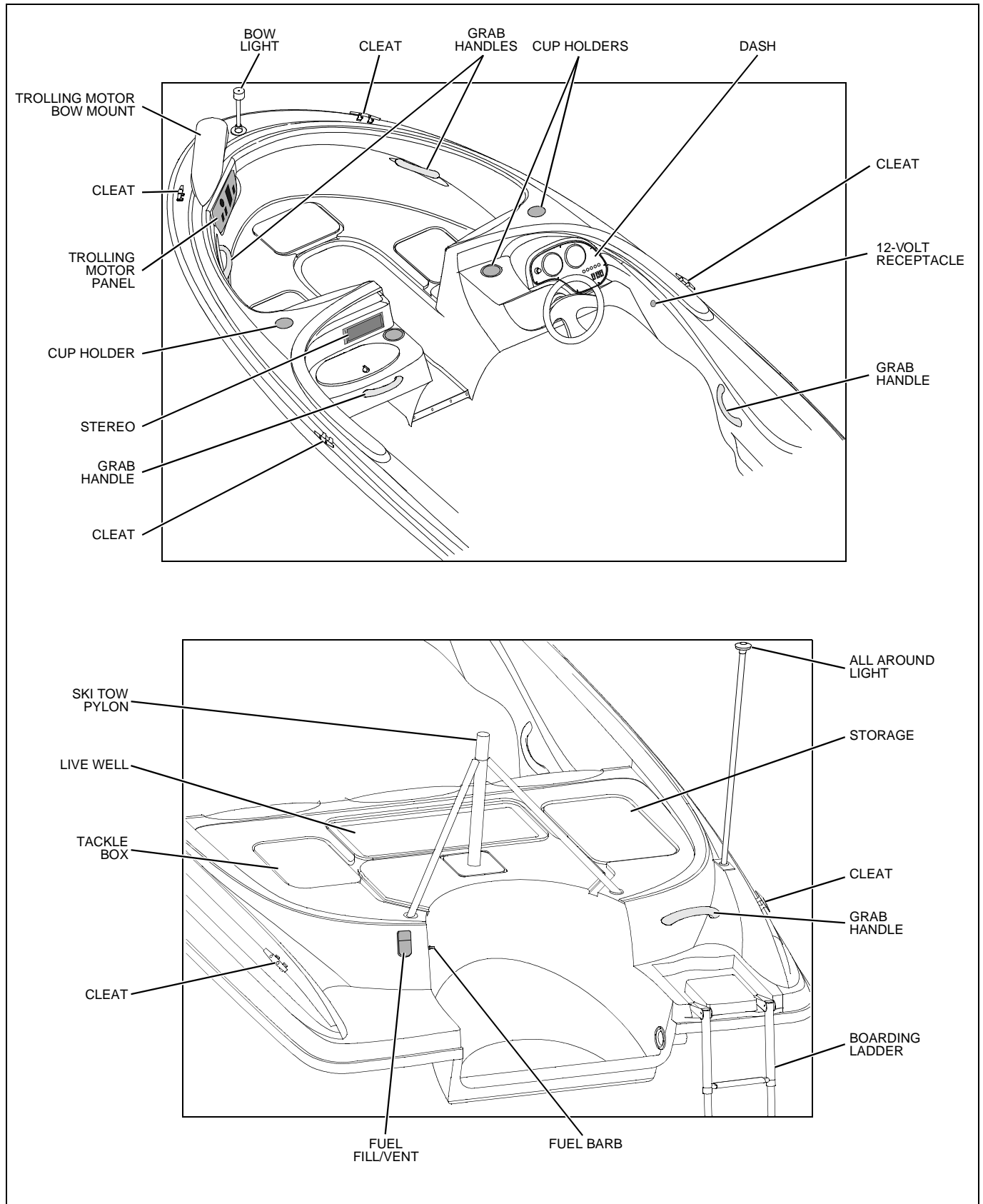

Component Locations

12-Volt Accessory Outlet: At the helm on the dash panel.

Battery: On the starboard side of the engine compartment

Bilge Pump: Access is through the deck plate in the motor well.

Engine Circuit Breaker: On the engine.

Fuel Fill: On the port side of the aft deck.

Fuse Panel: At the helm, below the dash panel.

Livewell/Baitwell Pump (184 Only): Access is through the deck plate in the motor well.

Livewell/Baitwell Seacock (184 Only): Access is through the deck plate in the motor well.

Navigation Lights: Red and green lights at the bow. White all-around light on the stern.

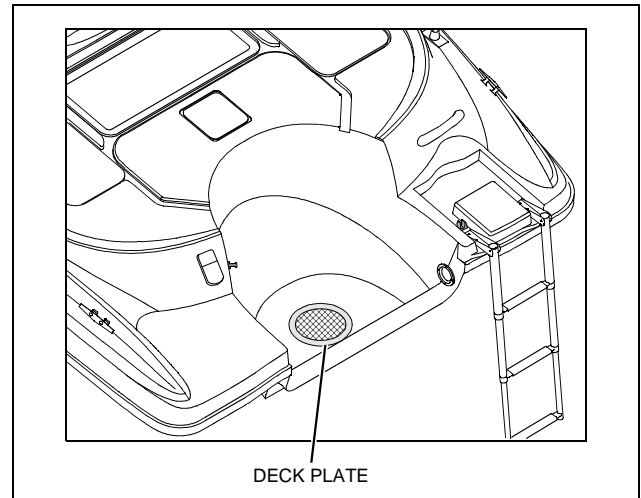

Chapter 4: Propulsion & Related Systems

Engine

Read the engine operation manual *before* starting or doing any maintenance on the engine.

Fuel System

! WARNING!

 **FIRE, EXPLOSION AND OPEN FLAME HAZARD!**

- It is very important that the fuel system be inspected thoroughly the first time it is filled and at each subsequent filling.
- The fueling instructions in the *Sport Boat Owner's Manual* and the fuel recommendations in the engine operation manual *must* be followed.

! CAUTION

Avoid the storage or handling of gear near the fuel lines, fittings and tank.

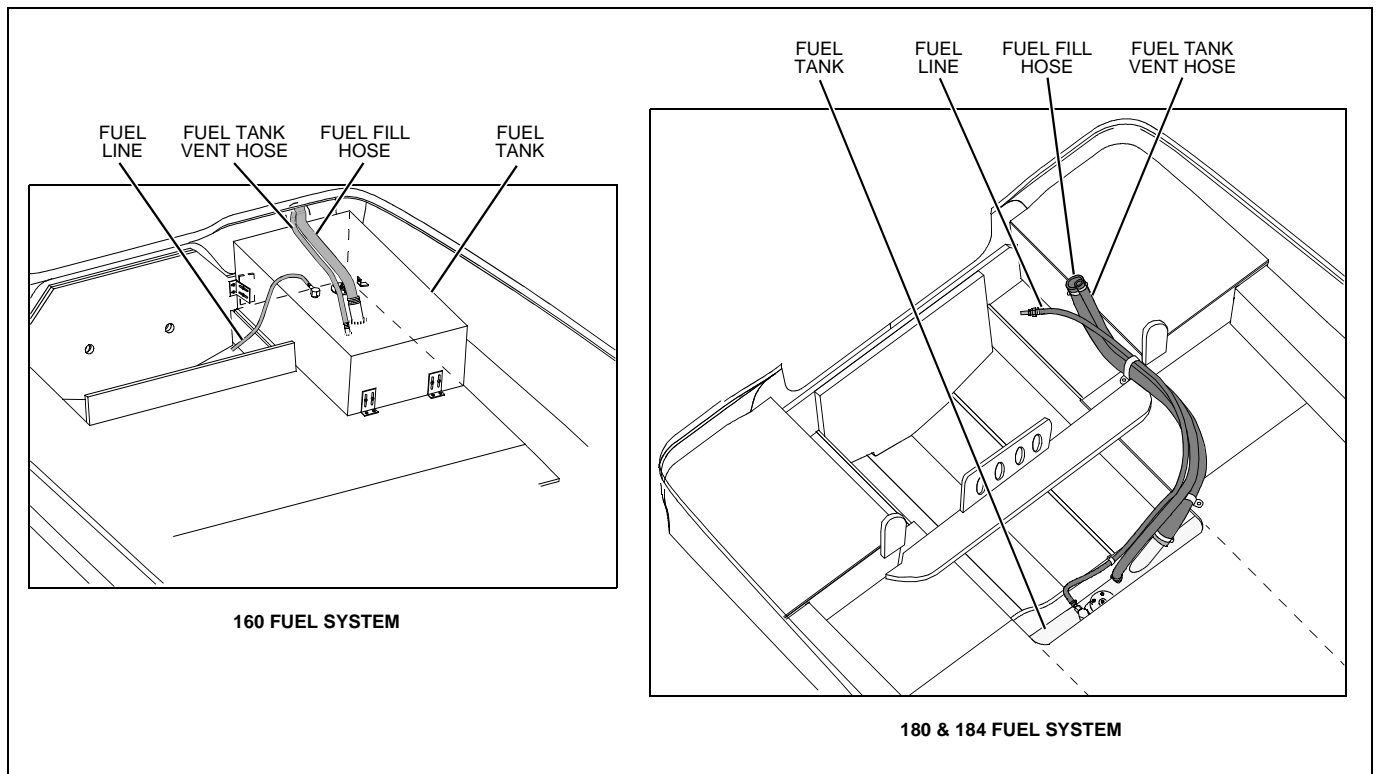

Fuel Fill and Vent

- The fuel fill/vent fitting is marked "GAS".
- If you experience difficulty filling the fuel tank, check to see if the fuel fill hose or vent hose is kinked or collapsed. If there are no visible signs of a problem, contact your local dealer.

Fuel Filters

- The fuel pickup tube (located inside the fuel tank) is equipped with a fine mesh screen filter.
- In addition, when supplied by the engine manufacturer, a fuel filter is installed on the engine.
- Periodically replace the fuel filters to make sure they remain clean and free of debris.
- Ask your dealer or local marina about fuel additives that help prevent fungus growth and/or other buildup in your fuel tank.

Chapter 5: Controls

Steering

- Refer to the engine manual for steering system details.

Shift/Throttle Lever

 WARNING!
<i>LOSS OF CONTROL HAZARD!</i>
Improper maintenance of shift/throttle hardware may cause a sudden loss of control!

Read *all* of the information about the shift/throttle lever in the shifter/throttle manual, the engine operation manual, and the *Sport Boat Owner's Manual*.

Power Trim and Tilt

- The outboard on your boat is equipped with power trim and tilt.
- Read about, Trim and Tilt or Drive Trim Angle in the engine operation manual, the shifter/throttle manual, and the *Sport Boat Owner's Manual*.

Chapter 6: Plumbing

Bilge Pump

NOTICE

Discharge of oil, oil waste or fuel into navigable waters is prohibited by law. Violators are subject to legal action by the local authorities.

- Your boat is equipped with a bilge pump for pumping water out of the bilge.
- The bilge pump is controlled by a switch at the helm.

Bilge Pump Testing

- The bilge pump is critical to the safety of your boat.
 - As follows, test the bilge pump often to make sure it is working.
1. Turn **On** the bilge pump switch at the helm.
 2. Any water in the bilge should pump overboard.
- If the pump motor is running, but **not** pumping, inspect the discharge hose for a kink or collapsed area.
 - If no problems are found, check the bilge pump housing for clogging debris as follows:

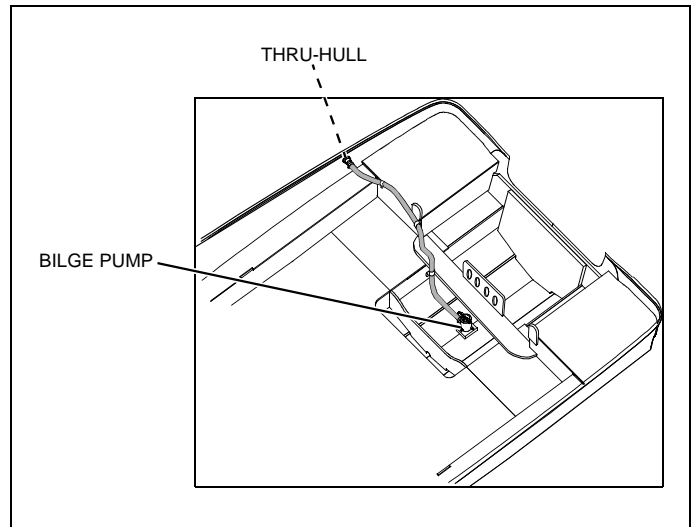

1. Remove the power cartridge:
 - a. Lift the tab while rotating the fins counter-clockwise.
 - b. Lift out the power cartridge.
 - c. Clear the outer housing of debris.
2. Reinstall the power cartridge:
 - a. Make sure the "O" ring is properly seated.
 - b. Coat the "O" ring with a light film of vegetable or mineral oil.
 - c. Align the cams on either side of the power cartridge with the two slots on the outer housing.
 - d. Press the power cartridge into the housing while twisting clockwise.
3. Check the reinstallation by trying to twist the fins counter-clockwise without lifting the tab; the cartridge should stay in place.

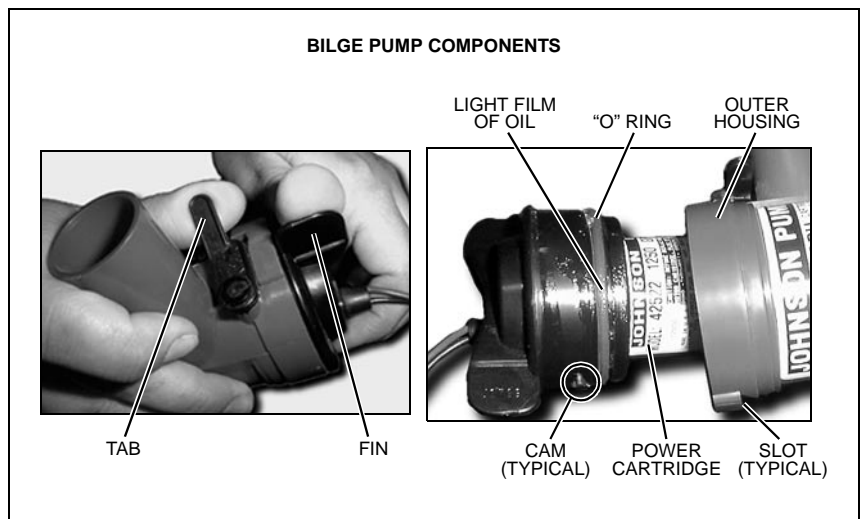

Seawater System (184 Only)

Seacock



CAUTION!

SYSTEM DAMAGE HAZARD!

- **Before** using a seawater intake system, make sure that the system's seacock is in the *Open* position **before** the system is started and keep the seacock *Open* until the system is shut *Off*.
- **Close** the seacock whenever the system *will not* be used for long periods of time.

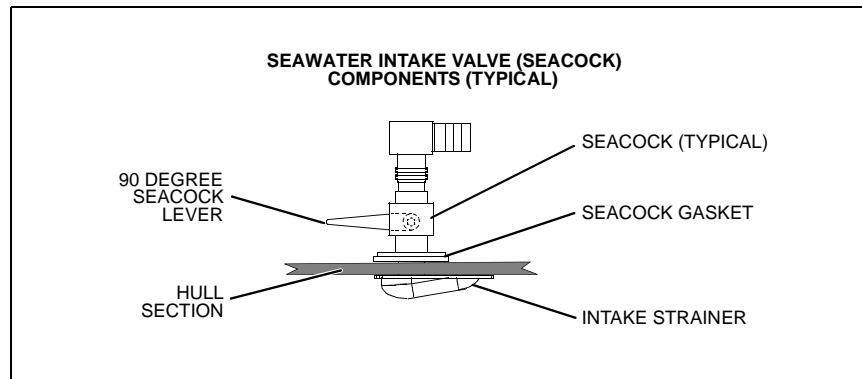

A seacock is a valve, controlled by a 90° lever, used to manage the intake of seawater through the hull and below the water line. The seawater intake system used on your boat is for the live well system (if equipped).

Before using this system, make sure that the system's seacock is *Open* and remains *Open* until the system is shut *Off*.

Baitwell System (184 Only)

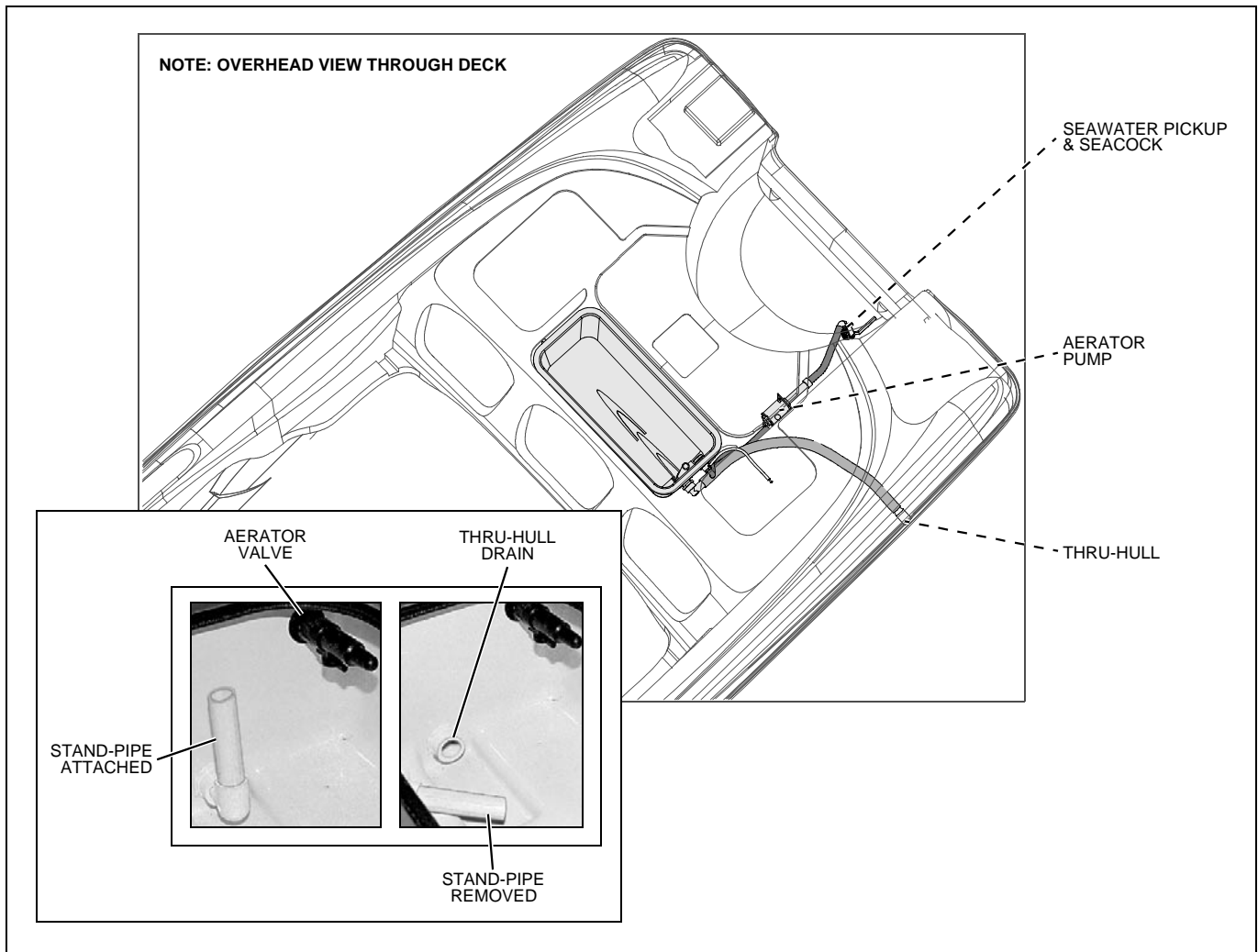

- **Open** the seacock **before** using the baitwell.
- Switches for the baitwell are located on the forward electrical panel and on the main dash panel.
- Either switch **will** turn **On** the aerator that pumps a continuous supply of fresh water into the baitwell.
- The overflow is automatically drained overboard through the stand-pipe.
- Check the baitwell system often to make sure that it is pumping adequate amounts of water.
- If there appears to be a problem, check the system for weeds or other debris.
- Completely drain the baitwell by removing the stand-pipe.

Chapter 7: Deck Equipment

Cleats and Tow Eyes

 **WARNING!**

PERSONAL INJURY and /or PRODUCT or PROPERTY DAMAGE HAZARD!

- ***NEVER*** lift the boat using the bow and stern eyes or the cleats.

Carefully read the section on towing in the *Sport Boat Owner's Manual* **before**:

- Towing anything behind the boat.
- Being towed by another vessel.

Pre-rigging For Trolling Motor (184 Only)

- The 184 features a trolling motor connection at the bow and a reinforced forward deck area designed to support a trolling motor mounting bracket.
- Contact your selling dealer for a list of compatible equipment and installation instructions.
- The trolling motor system can be used safely with either a 12V or a 24V motor. However, the voltage gauge will only register with a 24V motor.

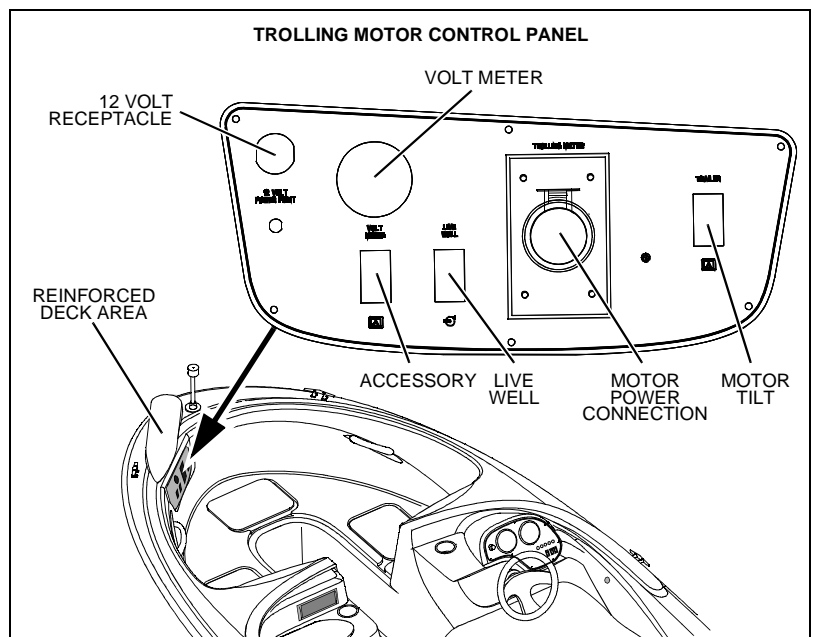

Ski Pylon (If Equipped)

 **WARNING!**

When the tow bar is in use, *all* passengers *must* sit forward of the ski pylon and keep their hands well clear of the pylon and rope. Failure to do so may result in *injury or death*.

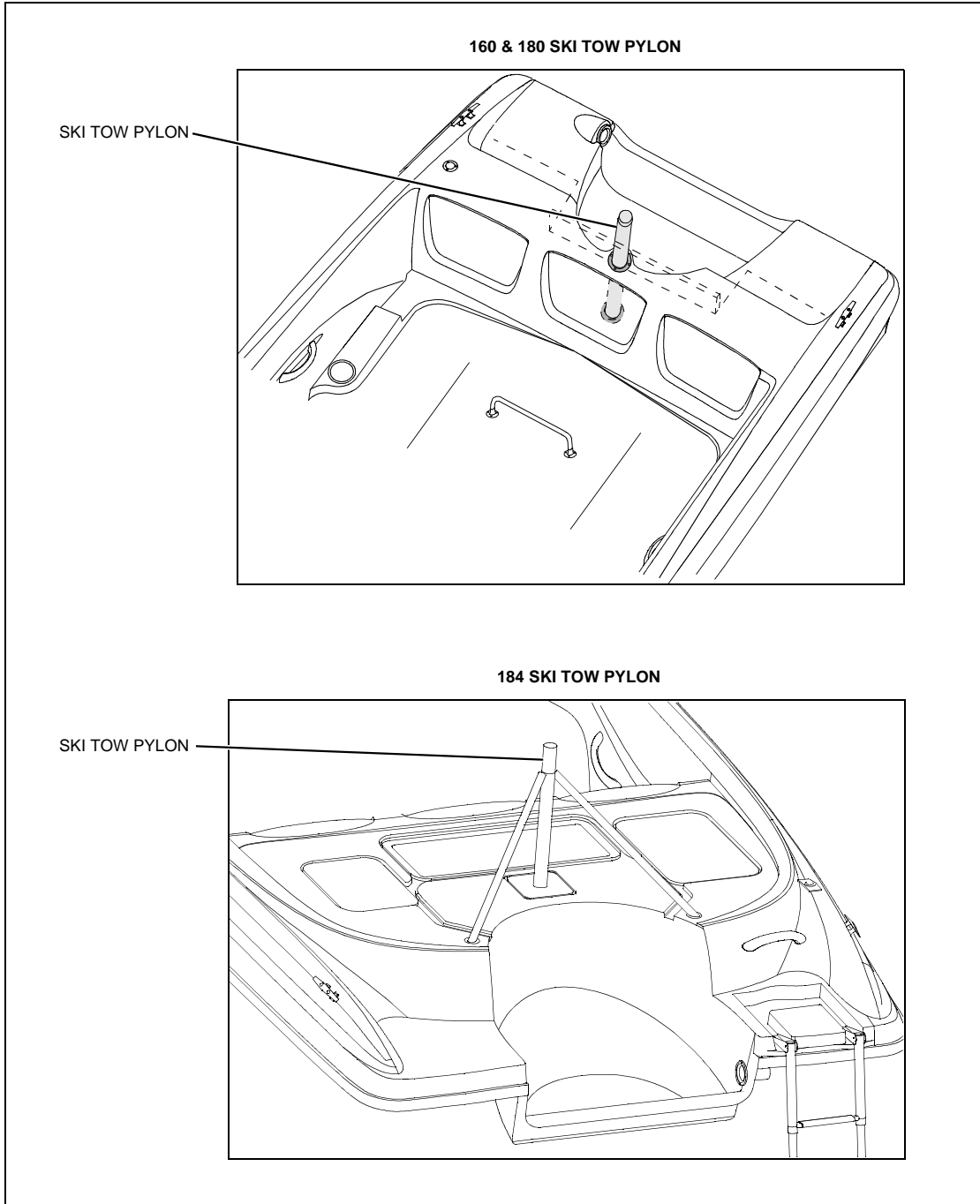

Your boat may feature a ski pylon. Read the manufacturer's installation instructions *before* using the ski pylon.

Canvas (If Equipped)



CAUTION!

PRODUCT or PROPERTY DAMAGE HAZARD!

- Canvas tops are *not* designed to withstand speeds over 45 MPH.
- Take down and securely stow the canvas top *before* transporting your boat by road.

180 Canvas Top (If Equipped)

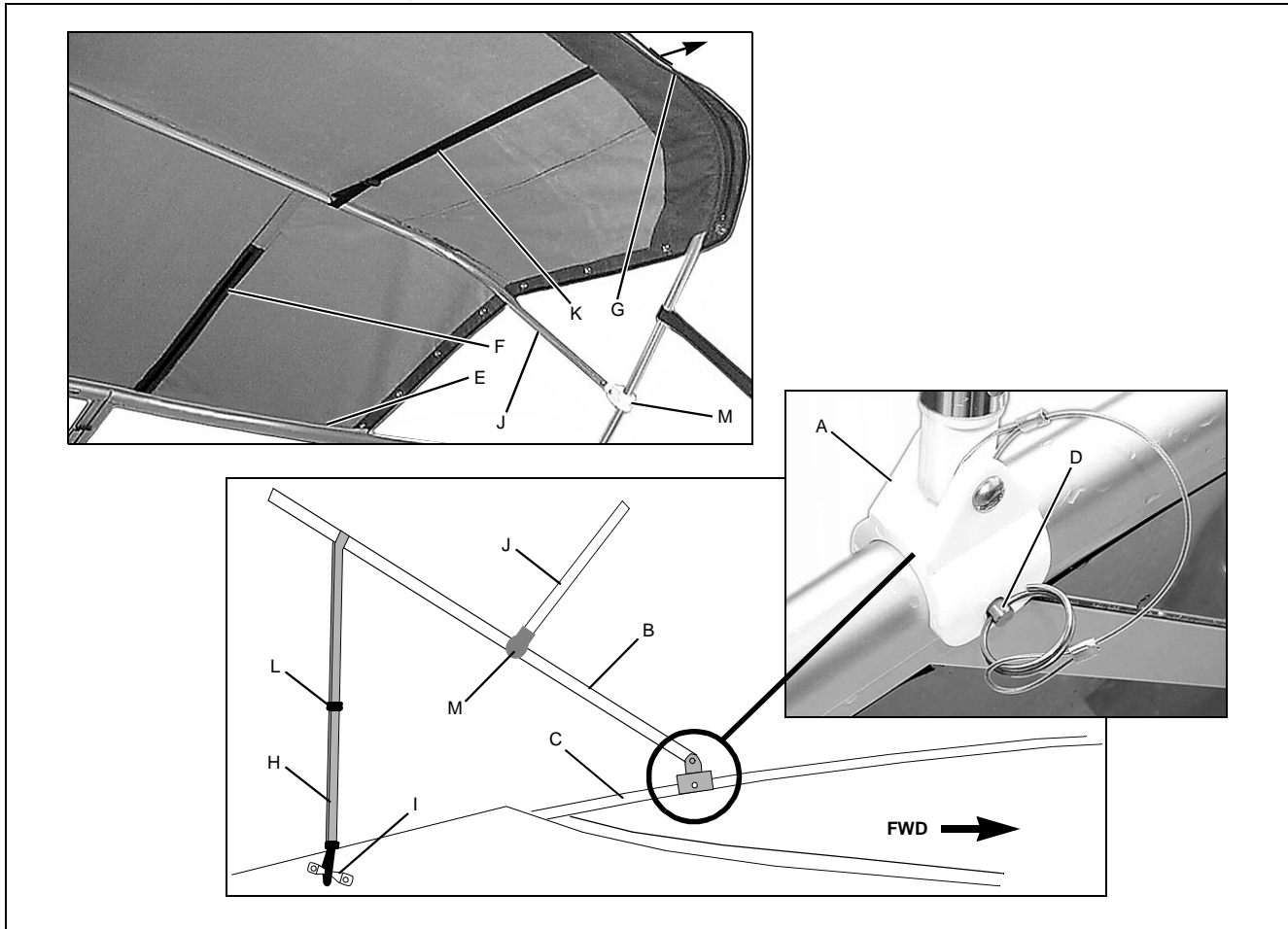

1. Slide the swivel ends (A) of the main bow (B) over the pre-drilled hole on each side windshield frame (C) and secure with the pins (D).
2. Unfold the canvas top and snap the front edge of the top (E) to the windshield frame.
3. Close the front zipper (F).
4. Pull aft on the aft edge of the top (G), making sure the canvas lies evenly from side to side and hook the hold down straps (H) to the deck loops (I).
5. Align the secondary bow (J) with the center seam of the canvas by loosening or tightening the top straps (K).
6. If the canvas top does *not* have a smooth, taut look, tighten the hold down straps by pulling on the strap buckles (L).
 - Since the jawslides (M) were preset during manufacturing they should *not* need to be adjusted.
 - However, if you think the jawslides need to be adjusted, obtain the correct measurements from your selling dealer.

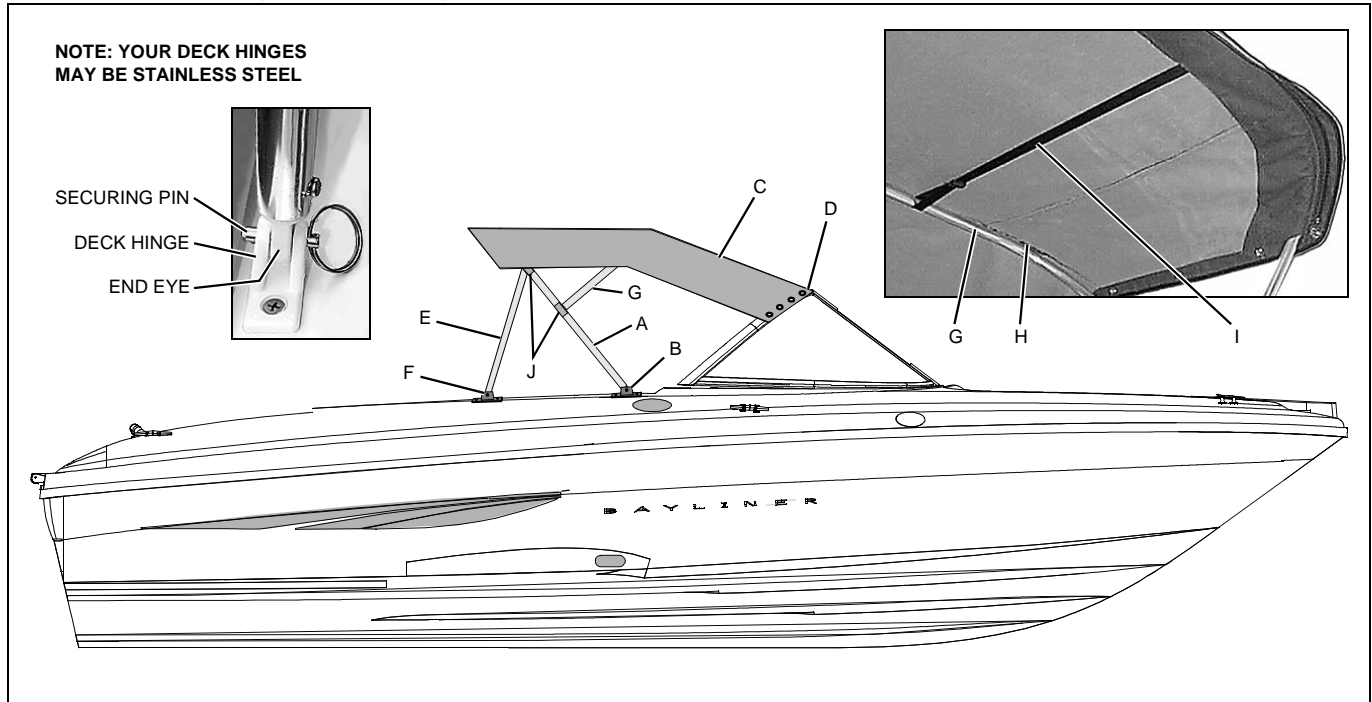
184 Canvas Top (If Equipped)

1. Insert the end eyes of the main bow (A) into the forward deck hinges (B) and secure with the pins.
2. Unfold the canvas top (C) and snap the front edge of the top (D) to the top of the windshield frame.
3. Insert the end eyes of the aft braces (E) into the aft deck hinges (F) and secure with the pins.
4. Align the secondary bow (G) with the center seam (H) of the canvas by loosening or tightening the top straps (I).
 - Since the jawslides (J) were preset during manufacturing they should *not* need to be adjusted.
 - However, if you think the jawslides need to be adjusted, obtain the correct measurements from your selling dealer.

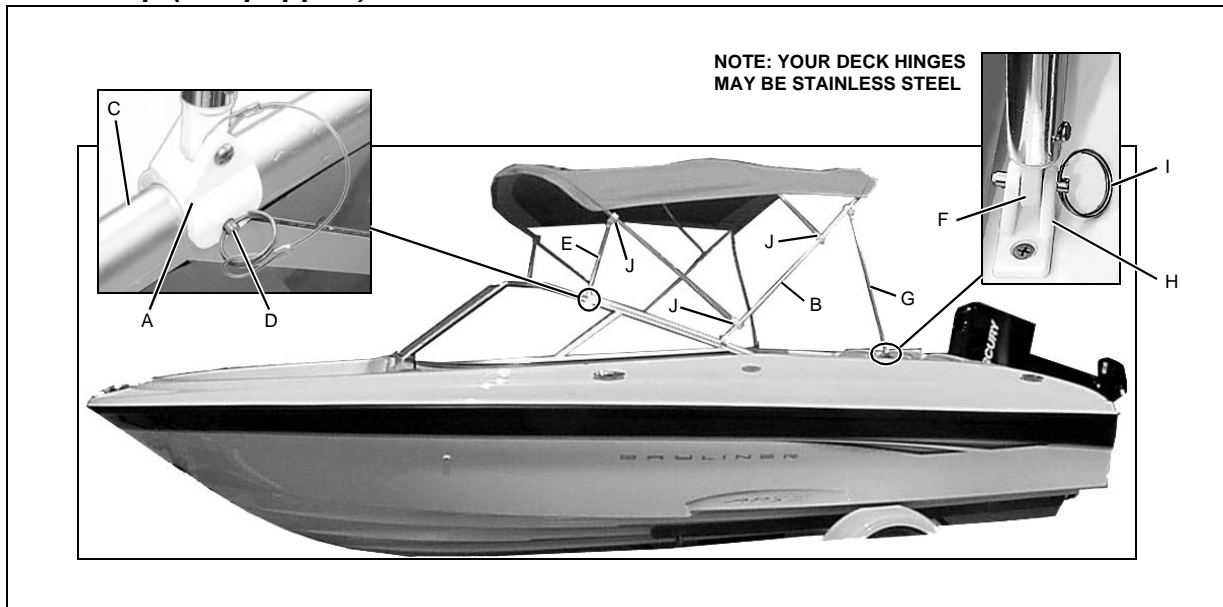
180 Bimini Top (If Equipped)

1. Slide the swivel ends (A) of the main bow (B) over the aft pre-drilled holes in the windshield frames (C) and secure with the pins (D).
2. Unfold the canvas top and slide the swivel ends of the forward legs (E) over the forward pre-drilled holes in the windshield frames and secure with the pins.
3. Insert the end eyes (F) of the aft legs (G) into the deck hinges (H) and secure with the pins (I).
 - Since the jawslides (J) were preset during manufacturing they should *not* need to be adjusted.
 - However, if you think the jawslides need to be adjusted, get the correct measurements from your selling dealer.

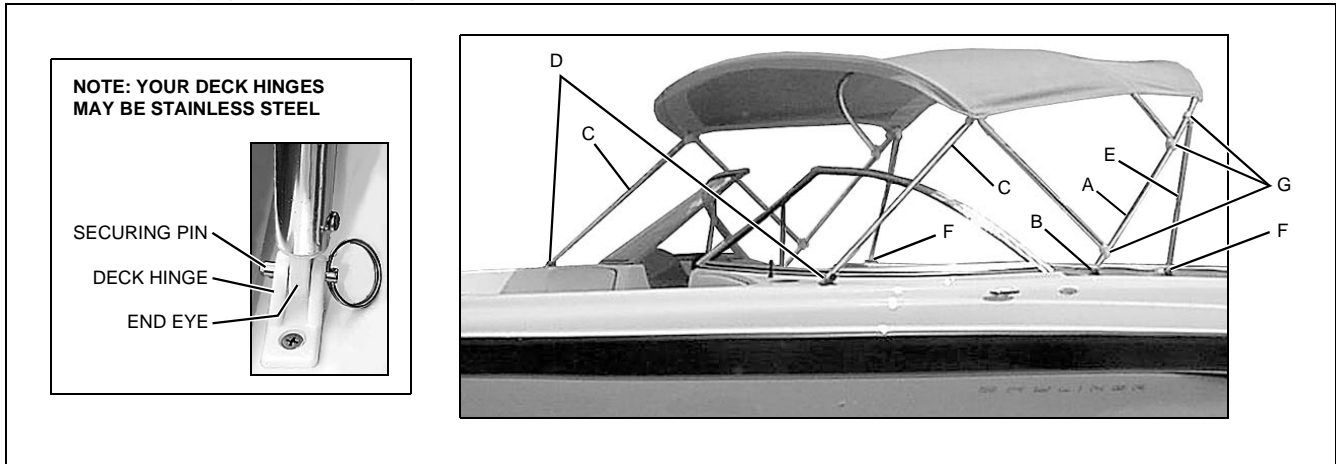
184 Bimini Top (If Equipped)

1. Insert the end eyes of the main bow (A) into the middle deck hinges (B) and secure with the pins.
2. Unfold the bimini top and insert the end eyes of the forward legs (C) into the forward deck hinges (D) and secure with the pins.
3. Insert the end eyes of the aft legs (E) into the aft deck hinges (F) and secure with the pins.
 - Since the jawslides (G) were preset during manufacturing they should **not** need to be adjusted.
 - However, if you think the jawslides need to be adjusted, obtain the correct measurements from your selling dealer.

Chapter 8: Entertainment Systems

Audio System (If Equipped)

NOTICE

AM radio reception may be impaired anytime the engine is running.

Read and understand the instruction manual for your boat's audio system *before* using.

Chapter 9: Convertible Seats

Sleeper Seats (If Equipped)

- The sleeper seats can be adjusted fore and aft in the upright, operating position.
- The seat bottoms adjust into backrests when the seats are in the lounge position.

Operating Positions

To slide the seat forward:

1. Lift the forward seat at point (A).
2. Push down on the forward seat at point (B) and pull the seat forward.
3. Lock the forward seat into the desired position by pushing down at point (A).
4. Lift the aft seat at point (C).
5. Push down on the aft seat at point (D) and push the seat forward until the aft seat back is flush against the forward seat back.
6. Lock the aft seat into position by pushing down at point (C).

To slide the seat aft, repeat the steps above, but start with the aft seat.

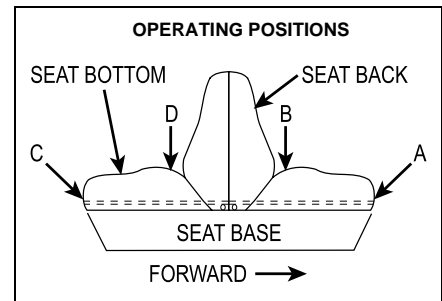

Lounge positions

To adjust into the flat lounge position:

1. Lift the forward seat at point (A).
2. Push down on the forward seat at point (B) and pull the seat forward until the seat back and bottom are flat.
3. Lift the aft seat at point (C).
4. Push down on the aft seat at point (D) and pull the seat aft until the seat back and bottom are flat.

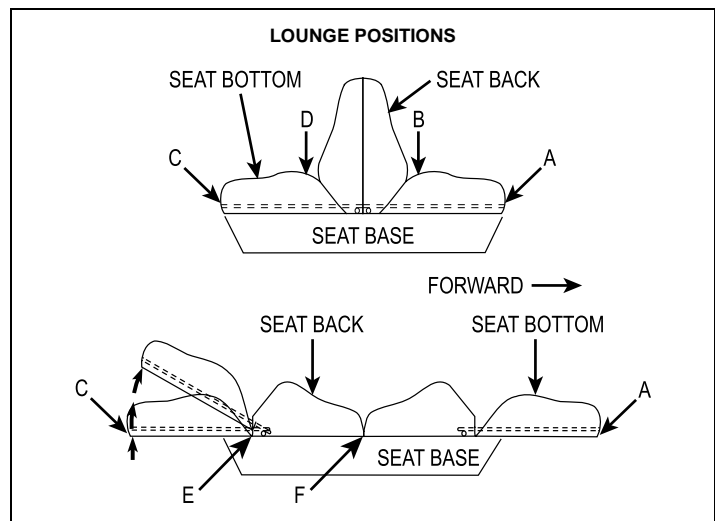

To adjust into the chaise lounge position:

1. Lift up on the forward or aft seat bottom at point (A or C) and push the seat bottom down into the locked position.
2. To lower the seat bottom, lift the seat at point (A or C). Drop the seat bottom flat while holding the seat down at point (E).

To return the seats to the operating position:

1. Lift the seat backs at point (F) and push down on the back edge of the seat bottom (B) and then seat bottom (D).
2. Push the seat bottoms towards the center of the seat until the seat backs are flush against each other and locked into place.

Removable Fishing Seats (184 Only)

**DANGER!**

**PERSONAL SAFETY HAZARD!**

- **DO NOT** allow anyone to ride on parts of the boat *not* designated for such use.
- Sitting on the fishing seat while underway is especially hazardous and **WILL** cause personal injury or death.

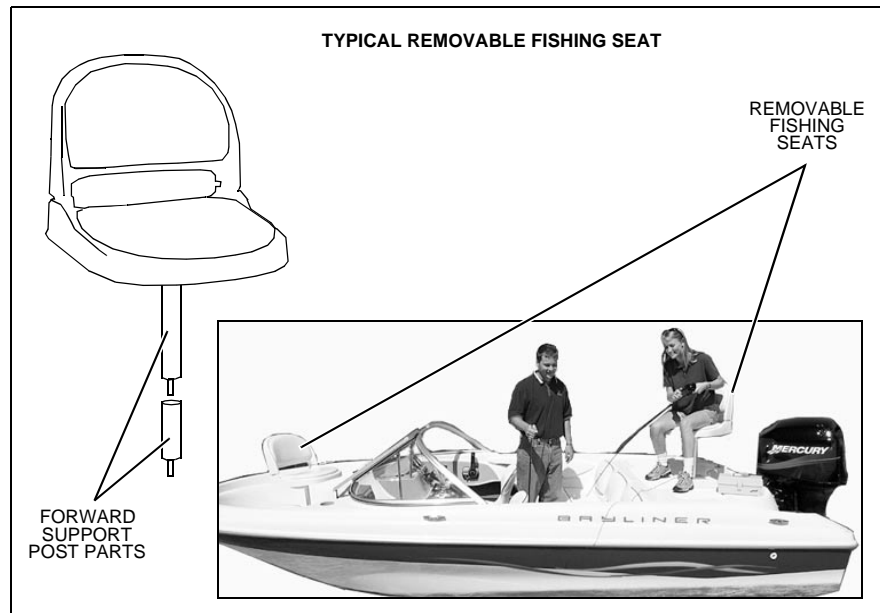

Remove and stow the fishing seats in a safe and secure area **before** getting underway or trailering your boat.

Chapter 10: Lights

Care and Maintenance

All of the lights installed on your boat are of top quality, but you should be aware that failure may periodically occur for a variety of reasons:

1. There may be a blown fuse - *replace the fuse.*
2. The bulb may be burned out - *carry spare bulbs for replacement.*
3. A wire may be damaged or may have come loose - *repair as required.*
4. The bulb base may be corroded - *clean the base and coat it with non-conductive electrical lubricant.*



Navigation Lights

 CAUTION!
Avoid the storage of gear where it would block navigation lights from view.

Read and understand the navigation light section of *Sport Boat Owner's Manual*.



Chapter 11: Electrical System

 **DANGER!**

   **EXTREME FIRE, SHOCK & EXPLOSION HAZARD!**

- To minimize the risks of fire and explosion, *NEVER* install knife switches or other arcing devices in the fuel compartments.
- *NEVER* substitute automotive parts for marine parts. Electrical, ignition and fuel system parts were designed and manufactured to comply with rules and regulations that minimize risks of fire and explosion.
- *DO NOT* modify the electrical systems or relevant drawings.
- Have qualified personnel install batteries and/or perform electrical system maintenance.

 **WARNING!**

   **FIRE & EXPLOSION HAZARD!**

- Visually and by smell (sniff test), check the engine and fuel compartments for fumes or accumulation of fuel.
- Minimize the danger of fire and explosion by *not* exposing the batteries to open flame or sparks. *NEVER* smoke anywhere near the batteries.

 **CAUTION!**

 **SHOCK & ELECTRICAL SYSTEM DAMAGE HAZARD!**

NEVER disconnect the battery cables while the engine is running since it can cause damage to your boat's electrical system components.

NOTICE

Electrical connections are prone to corrosion. To reduce corrosion caused electrical problems, keep *all* electrical connections clean and apply a spray-on protectant that is designed to protect connections from corrosion.

12-Volt DC System

Battery

The battery supplies electricity for lights, 12-volt accessories, and engine starting.

The Electrical section of Chapter 8, in the *Sport Boat Owner's Manual*, provides battery, care and maintenance instructions.

Fuses and Circuit Breakers

- Fuses for the engine and main accessory power are on the fuse block behind the dash.
- Some equipment may have secondary fuse protection at the unit, or at the battery.
- Electronics power is provided at the helm station.

Alternator

The engine alternator *will* keep the battery properly charged when running at cruising speeds.

12-Volt Accessory Outlet (If Equipped)

 CAUTION!
<i>DO NOT</i> use the 12-volt accessory outlet with a cigarette or cigar lighter. High temperatures may melt the outlet.

- Your boat is equipped with a 12-volt accessory outlet at the helm.
- The outlet can be used with any 12-volt device which draws 15 amps or less.
- The 12-volt accessory outlet is protected by 15 amp fuse on the main fuse block behind the dash.

Electrical Routings

160 Deck Electrical Harness

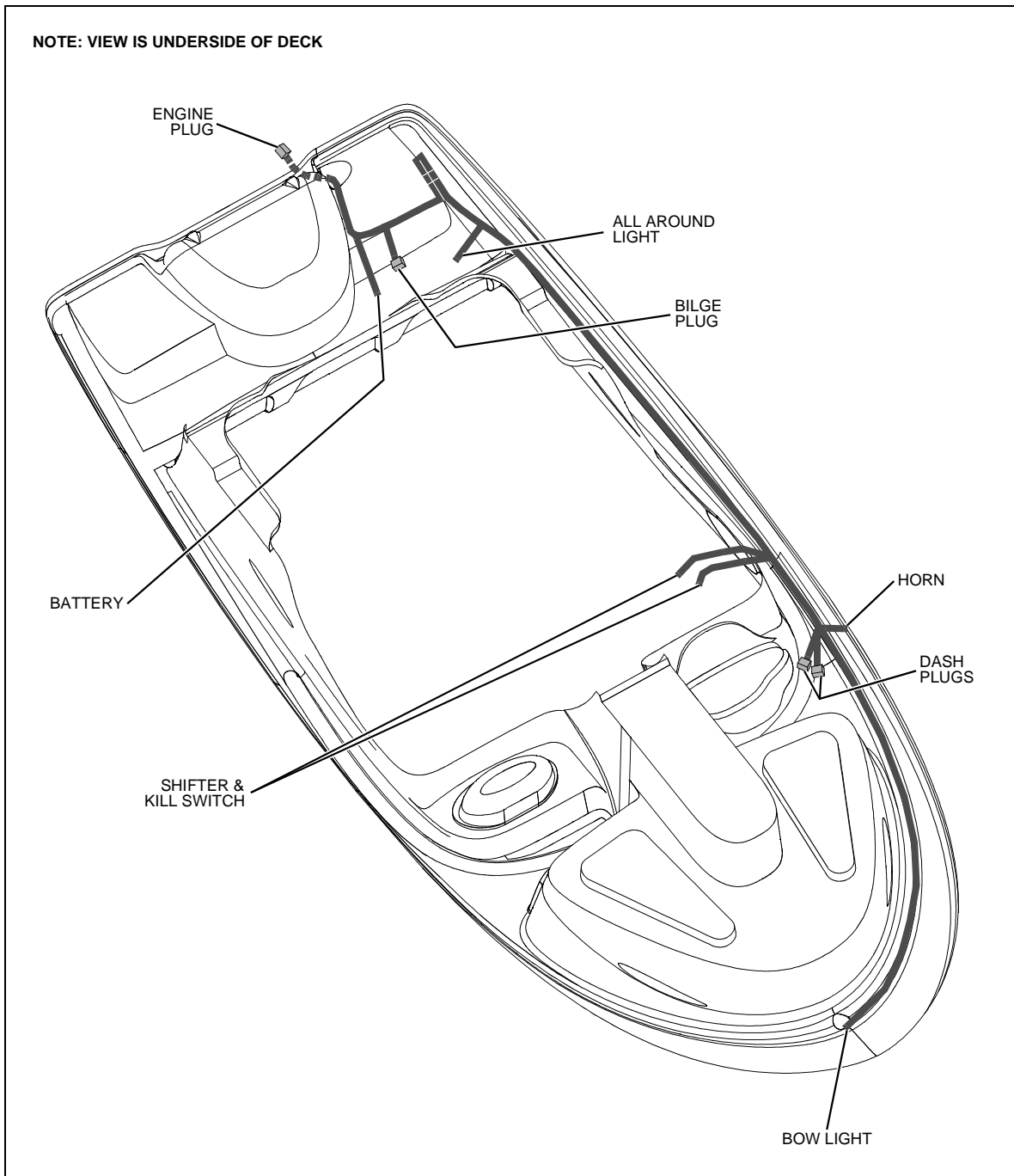

180 Deck Electrical Harness

NOTE: VIEW IS UNDERSIDE OF DECK

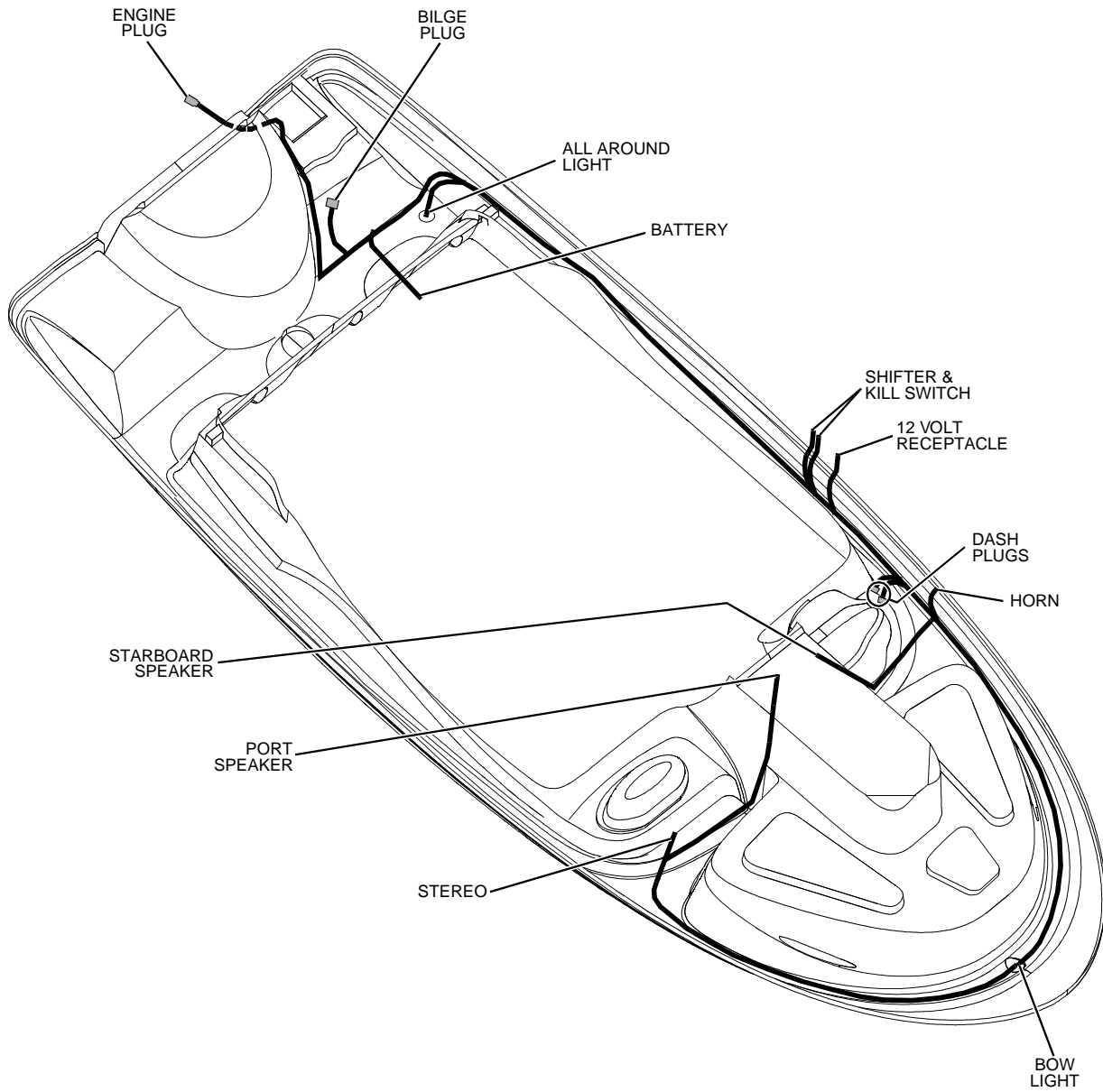

184 Deck Electrical Harness

NOTE: VIEW IS UNDERSIDE OF DECK

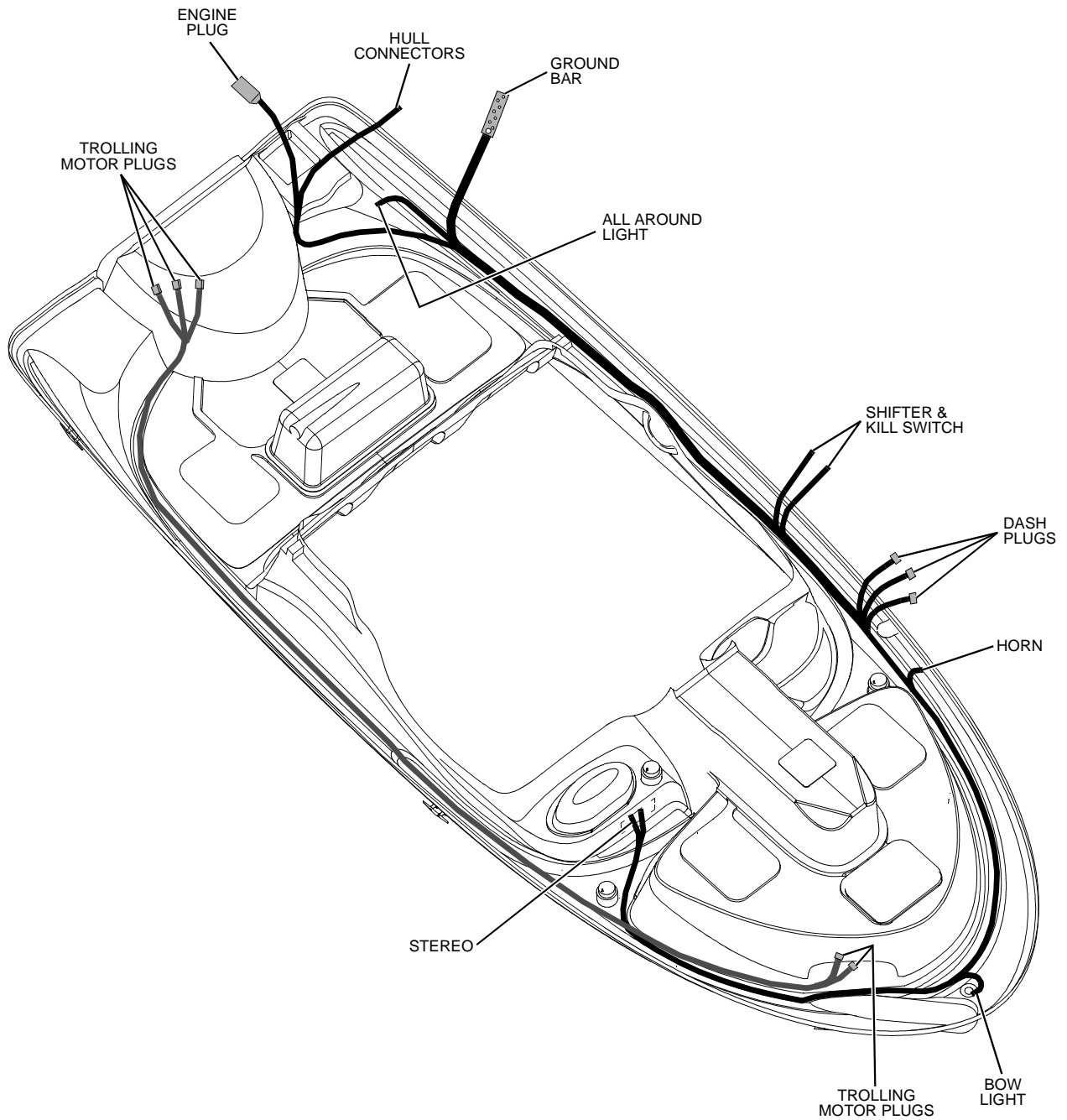

160 Hull Electrical Harness

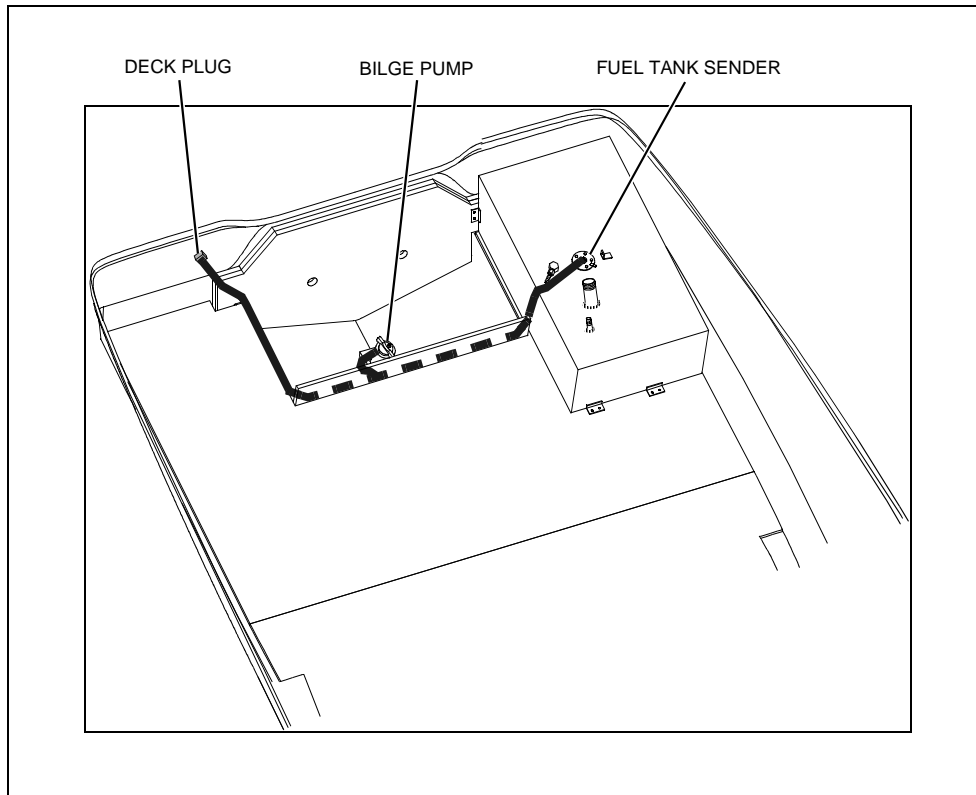

180 & 184 Hull Electrical Harness

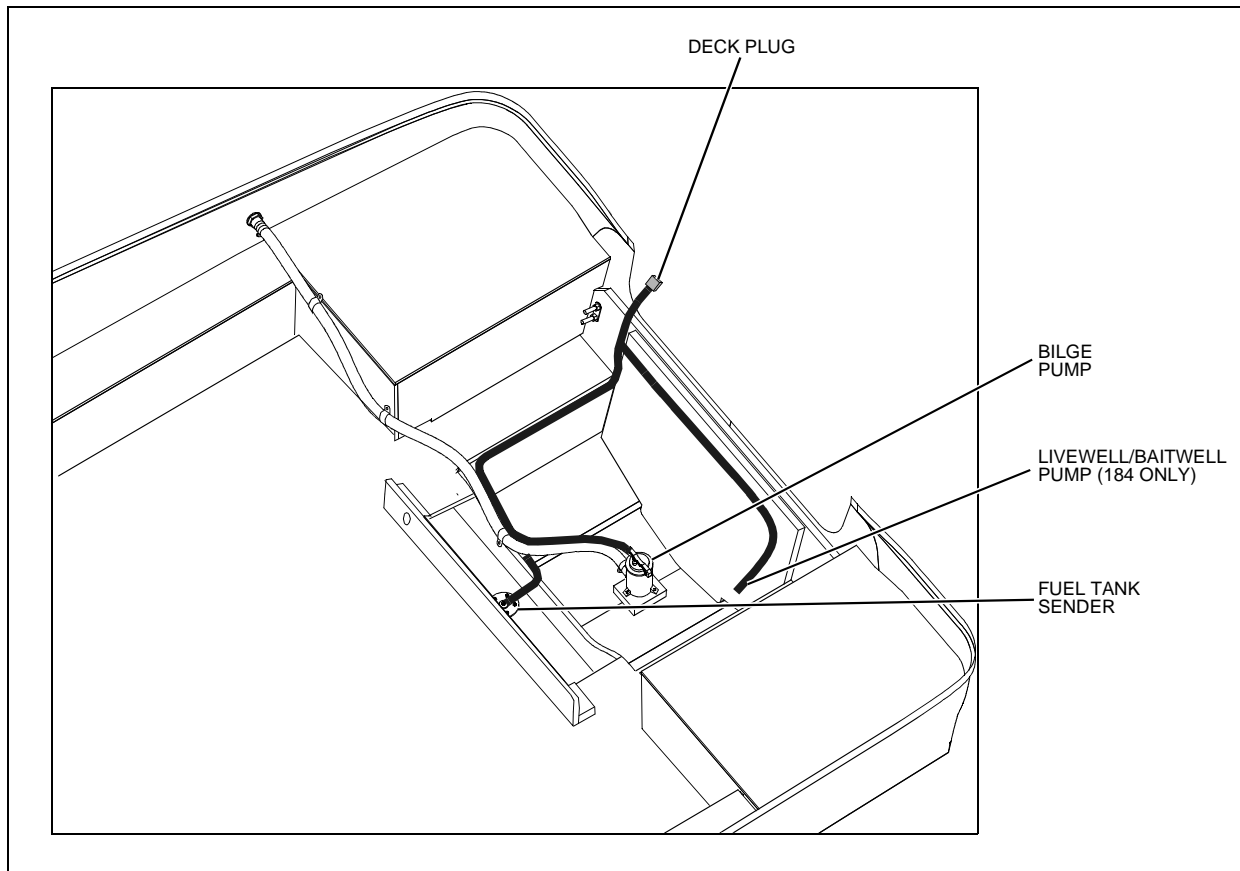

Wiring Diagrams

160 & 180

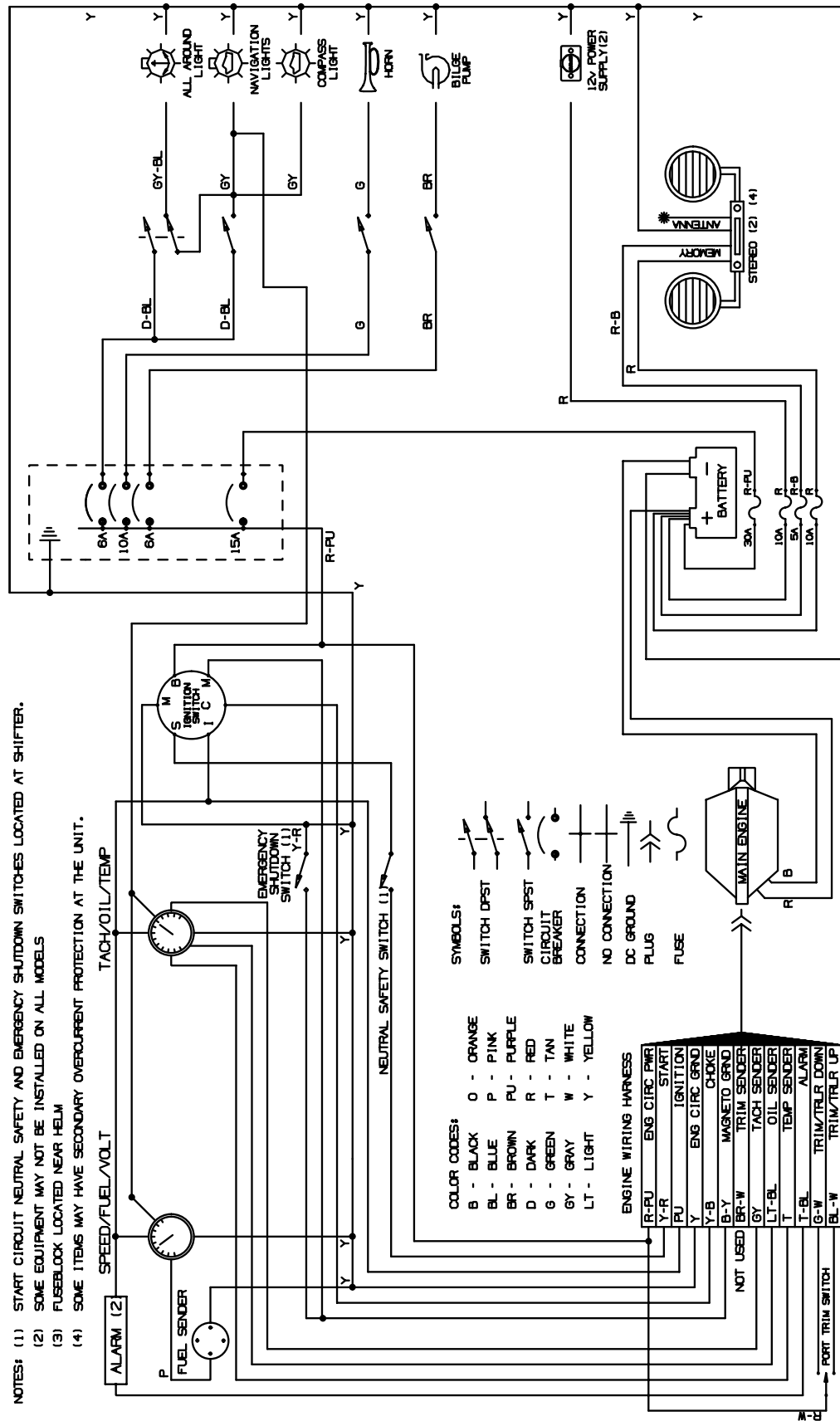

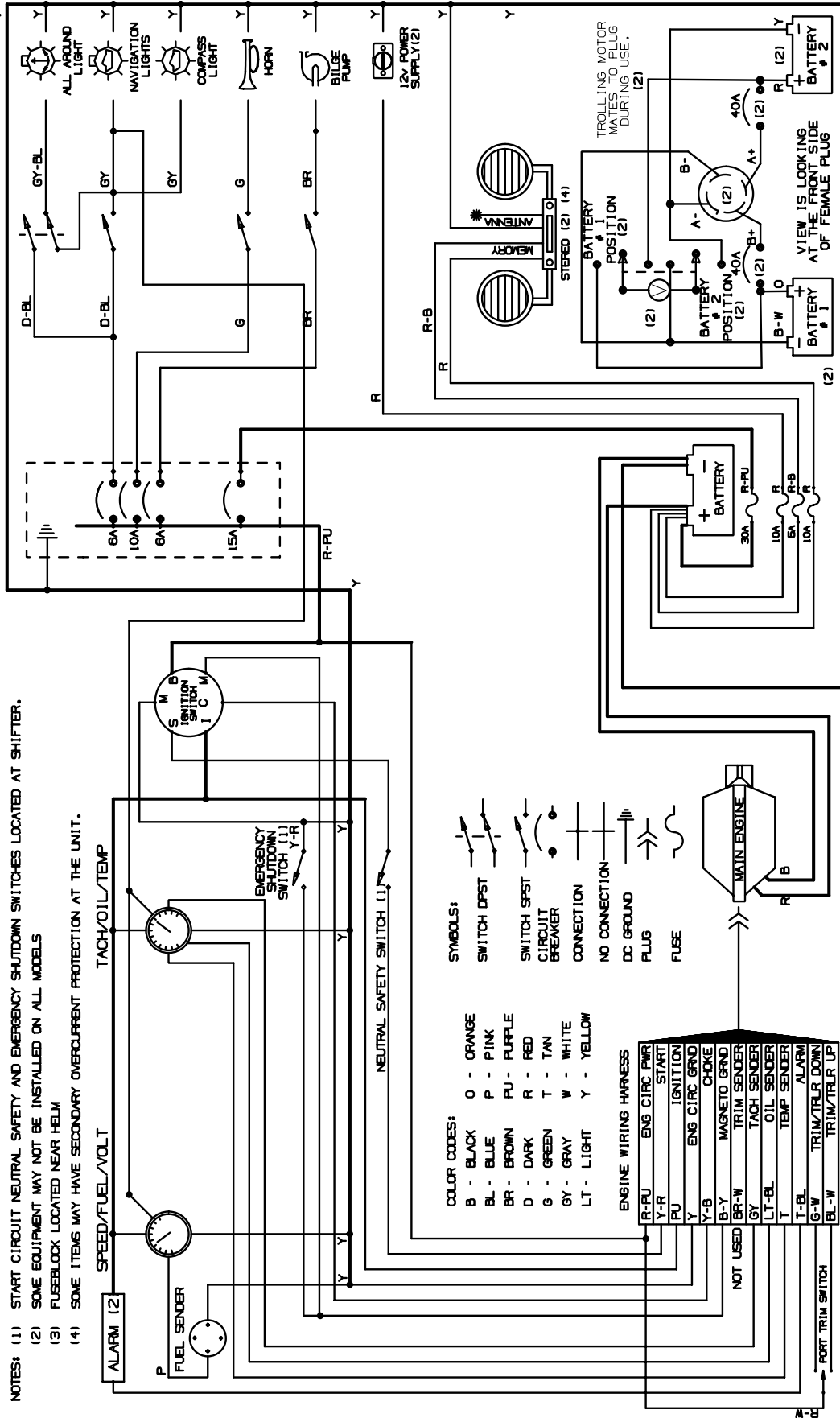

Trolling Motor Harness (184 Only)

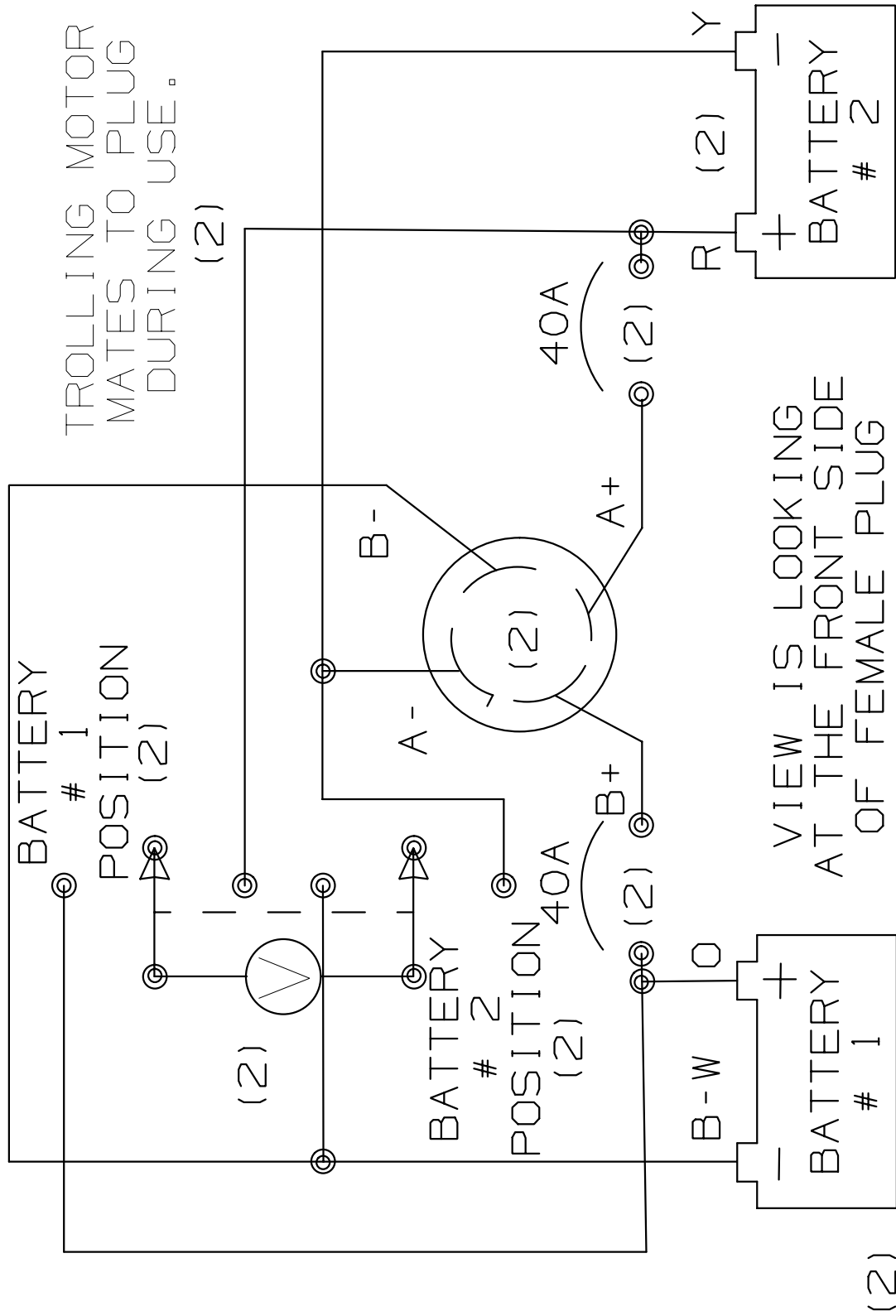

Important Records

Selling Dealer

Name Of Dealership

Address

Phone/FAX/E-mail

Sales Manager

Service Manager

Engine

Manufacturer

Model Name/Number

Engine Serial Number

Oil Type/SAE

Quarts per Engine

Filter Type

Propeller

Manufacturer

Pitch

Model Number

Key Numbers

Ignition

Other

Electronics

Manufacturer

Model Name/Number

Serial Number

Manufacturer

Model Name/Number

Serial Number

Manufacturer

Model Name/Number

Serial Number

Manufacturer

Model Name/Number

Serial Number

Float Plan

Before going boating, fill out a copy of this float plan (or similar) and leave it with a **reliable** person whom you can depend on to contact the Coast Guard or other rescue organization, if you do not return as scheduled.

Description of Boat

Registration/Documentation Number		
Length	Make	Type
Hull Color		Trim Color
Fuel Capacity	Engine Type	Number of Engines
Distinguishing Features		
Distinguishing Features		

Operator of Boat

Full Name		
Male or Female	Age	Health
Address		
Address		
Phone/FAX/E-mail		
Operator's Experience		

Persons on Board

Full Name		
Age	Health	Phone Number
Full Name		
Age	Health	Phone Number
Full Name		
Age	Health	Phone Number
Full Name		
Age	Health	Phone Number
Full Name		
Age	Health	Phone Number

Survival Equipment

Marine Radio (Yes/No)	Type	Frequencies
Number of PFDs	Flares (Yes/No)	Mirror (yes or no)
Smoke Signals (Yes/No)	Flashlight (Yes/No)	Food (Yes/No)
Water (Yes/No)	Anchor (Yes/No)	Raft/Dinghy (Yes/No)
Paddles (Yes/No)	EPIRB (Yes/No)	Other
Other	Other	Other

Vehicle Description

Make	Model
Color	License Number
Where is the Vehicle Parked?	

Trip Expectations

Departing From	
Departure Date	Departure Time
Stopover 1	
Arrive No Later Than: Date	Arrive No Later Than: Time
Stopover 2	
Arrive No Later Than: Date	Arrive No Later Than: Time
Stopover 3	
Arrive No Later Than: Date	Arrive No Later Than: Time
Stopover 4	
Arrive No Later Than: Date	Arrive No Later Than: Time
Stopover 5	
Arrive No Later Than: Date	Arrive No Later Than: Time
Stopover 6	
Arrive No Later Than: Date	Arrive No Later Than: Time
Final Destination Port (If Different Than Home Port)	
Arrive No Later Than: Date	Arrive No Later Than: Time

If not returned by the date and time listed above, call the Coast Guard or other local authority.

Coast Guard Phone Number
Local Authority Phone Number

Part Number 1738593

Bayliner • P.O. Box 9029 • Everett, WA 98206 • 360-435-5571